

Assembly Instructions

Hybrid 6'x12' - Merged Glazing

Approx. Dim.

370L x 185W x 209H cm / 145.6L" x 72.8W" x 82.3H"

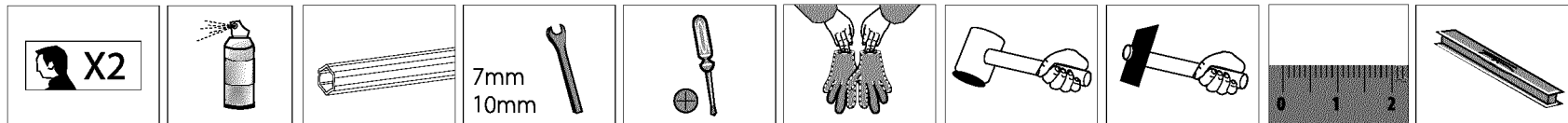

After Sale Service

Email: customer.service@palram.com

USA 877-627-8476
Canada 1 800-866-5749

England 01302-380775
Germany 0180-522-8778

France 0169-791-094
International +972 4-848-6942

www.palramapplications.com

IMPORTANT

Please read these instructions carefully before you start to assemble this greenhouse. Keep these instructions in a safe place for future reference.

⇒ Customer Service

For assistance with assembly or for replacement parts – please log onto our website or call our service line (number is on the title page).

Additional information can be found at our website: www.palramapplications.com

⇒ Safety Advice

- It is of utmost importance to assemble all of the parts according to the directions. Do not skip any step.
- We strongly recommend using work gloves during assembly.
- Always wear shoes and safety goggles when working with extruded aluminium.
- If using a step ladder or power tools ensure that you follow the manufacturer's safety advice.
- Do not touch overhead power cables with the aluminium profiles.
- Do not attempt to assemble the greenhouse in windy or wet conditions.
- Dispose of all plastic bags safely keep them out of reach of small children.
- Keep children away from the assembly area.
- Do not lean against or push the greenhouse during construction.
- Do not position your greenhouse in an area exposed to excessive wind.
- Do not attempt to assemble this greenhouse if you are tired, have taken drugs or alcohol or if you are prone to dizzy spell.
- Hot items such as recently used grills, blowtorches etc. must not be stored in the greenhouse. Ensure there are no hidden pipes or cables in the ground before inserting the pegs.
- This product is designed to use as greenhouse only.

⇒ Care & Maintenance

When your greenhouse needs to be cleaned, use a mild detergent solution and rinse with cold clean water. DO NOT use acetone, abrasive cleaners or other special detergents to clean the clear panels. It is recommended to check periodically that roof panels' caps (plastic part 329 & profile 981) are set in place.

⇒ Tools & Equipment

- Tape measure
- Work gloves
- Lubricant
- Phillips head screwdriver
- Step ladder
- Drill bit

- Large hammer
- Spanner
- T001 - Special tool for Screws 411 and nuts 412



⇒ Before Assembly

This is a multi-part assembly best achieved by two people. Allow at least half a day for assembly process.

Selecting a site - the greenhouse must be assembled, positioned and fixed on a flat level surface.

Choose a sunny position away from overhanging trees.

We are strongly recommend to fix your greenhouse directly to a solid concrete foundation. When doing that use the pre drilled holes in the metal base supplied.

Take out all components parts of the packages. Sort the parts and check against the contents parts list.

During assembly parts should be laid out close at hand. Keep all small parts (screws etc.) in a bowl so they do not get lost.

In purpose to facilitate parts' identification and assembly process, all-positioned profiles are used in this greenhouse. As a result some apertures in the profiles are not used during assembly.

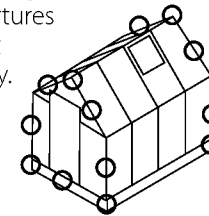

⇒ During Assembly

Carry out the assembly steps in the order set out in the instructions.

You may use Silicon lubricant spray in order to help you slide the profiles on the connectors. Do not spray the Polycarbonate panels. Use the rubber malet if necessary.



Step 1: Make sure the base is square by measuring the diagonals and level by using a spirit level.

Step 5: Part A994, A995 are in the back of the greenhouse. Fixing them determines the front side of the greenhouse.

Steps 8, 10, 15: The oval hole in the crossbars A256 should always be assembled to the base of the greenhouse.

Door assembly (Steps 9, 56-62)

Door can be installed as a left hand door or right hand door to your decision. These instructions show a right hand door assembly.

Step 9: determines door direction door post 987 is where door hinges will be located.

Steps 56-62: Door assembly should be done according to this decision.

Step 42: Decide on the window's location before assembly. Window can be installed in one of the indicated options.

Step 55: In case the window is not closed properly, please release the screws, adjust the profile and tighten the screw.

Step 68: Firmly connect the greenhouse to a level final position immediately after completion of the assembly.

Tighten all screws when completing assembly.

Screws 411 and nuts 412 are used throughout the assembly process.

- Screws 411 are to be assembled from the outside and nuts 412 from the inside of the greenhouse.
- Do not fasten screws and nuts (411 & 412) more than 2-3 turns only. Do not tighten them until completion of the panels' assembly, if not specified otherwise.
- However, in some steps, temporary tightening of a few screws may be needed to prevent a profile from falling till it will be fully connected in the next steps.



WICHTIG

Bitte lesen Sie diese Anweisungen sorgfältig durch, bevor Sie mit dem Aufbau des Gewächshauses beginnen.
Heben Sie diese Anweisungen an einem sicheren Ort auf, um später auf sie zurückgreifen zu können.

⇒ **Kundendienst**

Für Hilfe bei dem Aufbau oder für Ersatzteile – können Sie sich entweder auf unserer Webseite einloggen oder unseren Kundendienst anrufen (die Nummer steht auf der Titelseite).

Weitere Informationen finden Sie auf unserer Webseite: www.palamapplications.com

⇒ **Sicherheitshinweise**

- Es ist von grösster Wichtigkeit, alle Teile genau gemäss den Anweisungen zusammenzubauen. Lassen Sie keinen Schritt aus.
- Wir empfehlen wärmstens, während des Aufbaus Arbeitshandschuhe zu tragen.
- Tragen Sie immer Schuhe und eine Schutzbrille, wenn Sie mit stranggepresstem Aluminium arbeiten.
- Wenn Sie eine Stufenleiter oder Elektrowerkzeuge benutzen, achten Sie darauf, die Sicherheitshinweise des Herstellers zu befolgen.
- Berühren Sie mit den Aluminiumprofilen keine Oberleitungen.
- Versuchen Sie nicht, das Gewächshaus bei windigem oder regnerischem Wetter zusammenzubauen.
- Entsorgen Sie alle Plastiktüten sicher und bewahren sie ausserhalb der Reichweite von kleinen Kindern auf.
- Halten Sie Kinder vom Aufbaubereich fern.
- Während des Aufbaus sollten Sie sich nicht gegen das Gewächshaus lehnen oder es drücken.
- Bauen Sie Ihr Gewächshaus nicht an Orten mit hoher Windbelastung auf.
- Versuchen Sie nicht, dieses Gewächshaus aufzubauen wenn Sie müde sind, unter dem Einfluss von Drogen oder Alkohol stehen oder zu Schwindelanfällen neigen.
- Heisse Geräte wie kürzlich benutzte Grills, Schneidbrenner usw. dürfen nicht im Gewächshaus gelagert werden. Vergewissern Sie sich vor Einsetzen der Pflöcke, dass sich keine versteckten Rohre oder Kabel im Boden befinden.
- Dieses Produkt ist nur für den Einsatz als Gewächshaus geeignet.

⇒ **Pflege und Wartung**

Benutzen Sie eine milde Reinigungslösung für die Reinigung Ihres Gewächshauses und spülen es danach mit kaltem, sauberem Wasser ab. Benutzen Sie AUF KEINEN FALL Azeton, Scheuermittel oder andere spezielle Reinigungsmittel, um die klaren Platten zu reinigen.

⇒ **Werkzeuge & Ausrüstung**

- Maßband
- Arbeitshandschuhe
- Plastik- oder Gummihammer
- Schmiermittel
- Kreuzschlitzschraubenzieher
- Stufenleiter
- Bohrer

- Grosser Hamme
- Schere
- Schlüssel
- T001

⇒ **Vor dem Zusammenbau**

Diese ist eine Mehrteilige Montage. Der Zusammenbau der Teile wird am besten von zwei Leuten bewältigt. Rechnen Sie mit mindestens einem halben Tag für den Zusammenbau.

Wahl des Standorts - das Gewächshaus muss auf einem flachen ebenen Untergrund aufgebaut und fixiert werden. Wählen Sie eine sonnige Stelle ohne überhängende Bäume.

Wir empfehlen Ihnen sehr Ihr Gewächshaus direkt auf einem soliden Betonfundament zu befestigen. Dazu sollten Sie die vorgebohrten Löcher in der gelieferten Metallbasis benutzen.

Nehmen Sie alle Teile aus der Verpackung. Sortieren Sie die Teile und überprüfen Sie sie mit Hilfe der Inhaltsliste auf Vollständigkeit.

Während des Aufbaus sollten die Teile in Ihrer Nähe auf dem Boden ausgelegt werden. Bewahren Sie alle kleinen Teile (Schrauben usw.) in einer Schüssel auf, sodass sie nicht verloren gehen.

Um die Identifikation der Teile zu erleichtern und um die Montage zu vereinfachen, werden gleiche Profile in verschiedene Positionen eingebaut, sodass bei manchen Positionen einige Löcher dieser Profile während der Montage nicht verwendet werden.

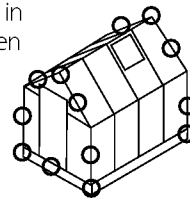
⇒ **Während des Zusammenbaus**

Führen Sie den Aufbau in der in den Gebrauchsanweisungen aufgeführten Reihenfolge Schritt per Schritt aus.

Sie können Silikonfett- Spray verwenden, um das Schieben der Profile 924 auf die Anschlüsse zu erleichtern.



Sprühen Sie nicht auf die Polycarbonatplatten.

Verwenden Sie den Gummihammer, falls nötig.

Schritt 1: Vergewissern Sie sich, dass die Basis sowohl quadratisch als auch waagrecht ist, indem Sie die Diagonalen messen und die Basis mit einer Wasserwaage prüfen.

Schritt 5: Teil A994, A995 sind in der Rückseite des Gewächshauses und deren Festsetzung bestimmt die Vorderseite des Gewächshauses.

Schritte 8, 10, 15: Das ovale Loch in den Querbalken A256 sollte immer auf die Basis des Gewächshauses montiert werden.

Das Zusammenbauen der Tür (Schritte 9, 56-62)

Die Tür kann nach Ihrer Entscheidung, entweder als eine Tür die sich nach Links öffnen lässt oder als eine Tür die sich nach Recht öffnen lässt, installiert werden. Die beigefügte Bauanleitung zeigt einen rechten Türbau.

Schritt 9: Bestimmt die Richtung der Tür. Türpost 987 ist wo die Türscharniere gelegt werden.

Schritte 56-62: Türzusammenbau sollte gemäß dieser Entscheidung folgen.

Schritt 42: Entscheiden sie über die genaue Lageposition des Fensters vor dessen Einbau. Das Fenster kann in einer der angegebenen Optionen installiert werden.

Schritt 55: Falls das Fenster nicht ordnungsgemäß verschlossen ist, bitte lösen Sie die Schrauben, Stellen Sie die Profile Zu und Befestigen Sie wieder die Schrauben.

Schritt 68: Befestigen Sie das Gewächshaus auf eine endgültige Position direkt nach Beendigung des Aufbaus auf einem waagrechten Untergrund.

Alle Schrauben befestigen nach dem abschluss der Montage

Schrauben 411 und Muttern 412 werden während des gesamten Aufbauvorgangs benutzt.

- Schrauben 411 werden von der Aussenseite des Gewächshauses eingesetzt und Muttern 412 von der Innenseite.
- Ziehen Sie die Schrauben und Muttern (411 und 412) nicht mit mehr als 2 – 3 Umdrehungen fest. Ziehen Sie sie erst nach Beendigung der Verglasung weiter fest, falls dies nicht ausdrücklich anders festgelegt ist.
- Sie sollten jedoch, in einigen Schritten, ein paar Schrauben vorübergehend festziehen um ein Profil von Fallen zu verhindern bis es in vollem Umfang in den nächsten Schritten verbunden wird.



IMPORTANT !

Veuillez lire attentivement ces instructions avant de commencer à monter votre serre.
Conservez ces instructions en lieu sûr pour toute consultation ultérieure.

⇒ **Service clientèle**

Pour toute assistance concernant le montage de la serre ou ses pièces de rechange – veuillez consulter notre site Internet ou appeler notre service technique (dont le numéro de téléphone figure sur la couverture de la brochure).

Pour en savoir plus, n'hésitez pas à visiter notre site Internet : www.palramapplications.com

⇒ **Consignes de sécurité**

- Très important ! Veuillez suivre scrupuleusement les instructions de cette brochure et réaliser les étapes dans l'ordre énoncé.
- Nous recommandons vivement le port de gants de protection pendant le montage.
- Portez toujours des chaussures de travail et des lunettes de protection lorsque vous travaillez des pièces en aluminium extrudé.
- Lors de l'utilisation d'une échelle ou d'outils électriques, assurez-vous de bien suivre les consignes de sécurité du fabricant.
- Veillez à ne pas toucher de câbles aériens avec les profilés en aluminium.
- N'essayez pas de monter la serre s'il y a du vent ou s'il fait humide.
- Jetez tous les sacs en plastique en appliquant les règles de sécurité et maintenez-les hors de portée des jeunes enfants.
- Eloignez les enfants de la zone d'assemblage.
- Ne vous appuyez pas contre la serre et ne la poussez pas pendant le montage.
- Ne positionnez pas la serre dans un endroit trop exposé au vent.
- N'essayez pas de monter la serre si vous êtes fatigué, si vous êtes sous l'effet de drogues, de médicaments ou d'alcool ou encore si vous êtes sujet aux vertiges.
- Les objets chauds tels qu'un barbecue, un chalumeau ou autre article ayant été récemment utilisés, ne doivent pas être rangés dans la serre.
- Avant de planter les piquets, assurez-vous qu'aucun tuyau ni câble n'est enterré à l'endroit sélectionné pour l'installation.
- Ce produit est conçu pour servir de serre exclusivement.

⇒ **Entretien & Maintenance**

Pour nettoyer votre serre, utilisez une solution détergente douce et à rincez à l'eau claire et froide. NE PAS utiliser d'acétone ni de produits nettoyants ou autres détergents spéciaux pour nettoyer les panneaux clairs. Il est recommandé de vérifier régulièrement que les couvre-joints des panneaux du toit sont bien en place (pièces en plastique 329 & profilé 981).

⇒ **Outils & Equipement**

- Mètre (ruban)
- Gants de travail
- Lubrifiant
- Tournevis cruciforme (Philips)
- Escabeau
- Perceuse
- Grand marteau
- Clé à écrous
- T001 – outil spécial pour vis 411 et écrous 412

⇒ **Avant le montage**

Il s'agit d'un assemblage à pièces multiples qu'il est préférable de réaliser à deux personnes et auquel il faut consacrer au moins une demi-journée.

Sélection du site – la serre doit être montée et fixée sur une surface plane.

Choisissez un emplacement ensoleillé et éloigné d'éventuels arbres susceptibles de la surplomber.

Nous recommandons vivement de fixer la serre directement à de solides fondations en béton. Pour ce faire, utilisez les trous déjà percés dans le châssis métallique fourni.

Sortez toutes les pièces de leurs emballages. Triez-les et comparez-les avec la liste des pièces pour vérifier que tout y est.

Lors de l'assemblage, les pièces doivent être disposées à portée de main. Gardez toutes les petites pièces (vis, etc.) dans un récipient pour éviter de les perdre.

Pour faciliter l'identification des pièces et la procédure de montage, les profilés utilisés pour la construction de cette serre sont tous déjà en place. En conséquence, certaines ouvertures des profilés restent inutilisées pendant le montage.

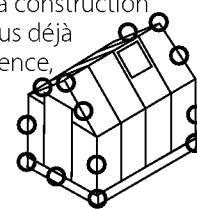
⇒ **Pendant le montage**

Procédez au montage étape par étape, en respectant l'ordre énoncé dans cette brochure.

Vous pouvez utiliser un spray lubrifiant en silicone afin de vous aider à insérer les profils dans les connecteurs. Veillez à ne pas asperger les panneaux de polycarbonate. Utilisez le maillet en caoutchouc si nécessaire tout en prenant soin de ne pas abîmer les connecteurs en plastique.



Etape 1 : Assurez-vous que le châssis est bien carré en mesurant les diagonales, et vérifiez sa mise à niveau à l'aide d'un niveau à bulle.

Etape 5 : les pièces A994, A995 sont à l'arrière de la serre. Le fait de les fixer détermine également la position de la façade de la serre.

Etapes 8, 10, 15 : L'ouverture ovale des barres transversales A256 doit toujours être placée du côté du châssis de la serre.

Montage de la porte (Etape 9, 56-62) : La porte peut être installée avec la poignée à gauche ou à droite à votre convenance. Ces instructions sont basées sur une installation avec la poignée à droite.

Etape 9 : Déterminez l'orientation de la porte. Le montant de porte 987 est celui sur lequel seront fixées les charnières.

Etapes 56-62 : Le montage de la porte doit être réalisé selon la décision prise à ce stade.

Montage de la fenêtre (Etape 42, 55) :

Etapes 42 : Choisissez l'emplacement de la fenêtre avant le montage, parmi les options indiquées.

Etape 55 : Dans le cas où la fenêtre ne ferme pas correctement, veuillez relâcher les vis, ajuster le profil, et de nouveau resserrer les vis.

Etape 68 : Immédiatement après avoir terminé l'assemblage, fixez solidement la serre en position finale, parfaitement horizontale.

Serrez toutes les vis après avoir achever l'assemblage.

Les vis 411 et écrous 412 servent tout au long de la procédure.

- Les vis 411 se placent à l'extérieur et les écrous 412 à l'intérieur de la serre.
- Ne serrez les vis et écrous (411 & 412) que de 2 à 3 tours, pas plus. Ne les serrez pas tant que l'assemblage n'est pas complètement terminé, sauf indication contraire.
- Cependant, la réalisation de certaines étapes peut nécessiter le serrage provisoire de quelques vis pour empêcher un profilé de tomber en attendant qu'il soit entièrement intégré à l'ensemble de la structure dans les étapes suivantes.



IMPORTANTE

Por favor, lea estas instrucciones cuidadosamente antes de empezar a montar este invernadero.

Mantenga estas instrucciones en un lugar seguro para referencia futura.

⇒ Servicio de Ayuda al Cliente

Para obtener ayuda con el montaje o para las piezas de recambio - por favor entre a nuestro sitio web o llame a nuestra línea de servicio (el número está en la página de título).

Información adicional se puede encontrar en nuestro sitio web: www.palramapplications.com

⇒ Consejo de Seguridad

- Es de suma importancia montar todas las partes de acuerdo con las instrucciones. No se salte ningún paso.
- Recomendamos firmemente el uso de guantes de trabajo durante el montaje.
- Use siempre zapatos y gafas de seguridad al trabajar con aluminio extruido.
- Al usar una escalera plegable o herramientas eléctricas asegúrese de que sigue las instrucciones de seguridad de los fabricantes.
- No toque los cables eléctricos aéreos con los perfiles de aluminio.
- No intente montar el invernadero en días de viento o días con humedad.
- Disponga todas las bolsas plásticas en lugar seguro - guárdelas fuera del alcance de niños.
- Mantenga a los niños fuera del área de montaje.
- No se apoye ni empuje el invernadero durante la construcción.
- No coloque su invernadero en un área expuesta al viento excesivo.
- No intente montar este invernadero si usted está cansado, ha tomado drogas o alcohol o si usted es propenso a ataques de mareo.
- Artículos calientes recientemente usados tales como parrillas, sopletes etc. no deben ser almacenados en el invernadero. Asegúrese de que no haya ninguna tubería o cables ocultos en la tierra antes de insertar las clavijas.
- Este producto es designado a ser usado solamente como invernadero.

⇒ Cuidados & Mantenimiento

Cuando su invernadero necesite limpieza, utilice una solución detergente suave y enjuague con agua limpia fría. NO UTILICE acetona, limpiadores abrasivos u otros detergentes especiales para limpiar los paneles. Se recomienda comprobar periódicamente que los paneles del techo > tapones (parte de plástico 329 y perfil 981) están colocados en el lugar.

⇒ Herramientas & Equipos

- Cinta métrica
- Broca
- Guantes de trabajo
- Martillo grande
- Lubricante
- Llave inglesa
- Escalera plegable
- Destornillador cabeza de tornillo Phillips
- T001 – Herramienta especial para Tornillos 411 y Tuercas 412

**⇒ Antes del Montaje**

Esto es un montaje de varias partes, mejor ejecutado por dos personas. Dé un plazo de por lo menos medio día para el proceso de montaje.

Seleccionar un sitio – el invernadero debe ser montado, posicionado y fijo en una superficie plana.

Elija un lugar soleado lejos de árboles con ramas colgantes.

Recomendamos firmemente que fije su invernadero directamente a una fundación de concreto sólido. Al hacer esto, utilice los agujeros perforados en la base de metal proveída.

Saque todas las partes componentes de los paquetes. Clasifique las partes y compruebe contra la lista del contenido.

Durante el montaje las partes deben ser colocadas cerca del alcance de la mano. Guarde todas las piezas pequeñas (tornillos etc.) en un tazón para que no se pierdan.

En el propósito de facilitar la identificación de las partes y el proceso de montaje, todos los perfiles posicionados son usados en este invernadero.

Consecuentemente algunas aberturas en los perfiles no son utilizadas durante el montaje.

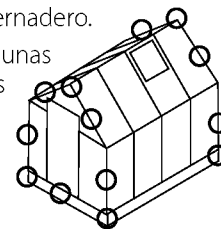
**⇒ Durante el Montaje**

Ejecute los pasos del montaje en el orden indicado en las instrucciones.

Usted puede utilizar el aerosol de lubricante de silicona para ayudar a deslizar los perfiles en los conectores. No rocíe los paneles de policarbonato. Use el mazo de goma si fuere necesario.



Paso 1: Cerciórese de que la base sea cuadrada midiendo las diagonales y el nivel usando un nivel de burbuja.

Paso 5: Partes A994, A995 están en la parte posterior del invernadero. Fijándolas se determina la parte delantera del invernadero.

Pasos 8, 10, 15: El agujero oval en las barras transversales A256 debe ser siempre montado a la base del invernadero.

Montaje de la puerta (Pasos 9, 56-62)

La puerta puede ser instalada como una puerta de mano izquierda o derecha a su decisión. Estas instrucciones muestran un montaje de puerta de mano derecha.

Paso 9: determina la dirección de la puerta; la jamba 987 de la puerta es donde las bisagras serán ubicadas.

Pasos 56-62: El montaje de la puerta debe ser realizado según esta decisión.

Paso 42: Decida sobre la localización de la ventana antes del montaje. La ventana puede ser instalada en una de las opciones indicadas.

Paso 55: En caso de que la ventana no se cierra correctamente, afloje los tornillos, ajustar el perfil y apretar el tornillo.

Paso 68: Conecte firmemente el invernadero a un nivel de posición final inmediatamente después de la finalización de la asamblea.

Apriete todos los tornillos de montaje al completar.

Los tornillos 411 y las tuercas 412 son usados durante todo el proceso de montaje.

- Los tornillos 411 deben ser montados desde el exterior y las tuercas 412 desde el interior del invernadero.
- No apriete los tornillos y tuercas (411 y 412) más de 2-3 vueltas. No los apriete hasta terminar el montaje de los paneles, a menos que orientado de otra manera.
- Sin embargo, en algunos pasos, el ajuste temporal de algunos tornillos puede ser necesario para evitar que un perfil caiga hasta que sea conectado completamente en los pasos siguientes.



Viktigt

Läs noga igenom dessa instruktioner innan ni börjar montera växthuset. Förvara dessa instruktioner på en säker plats för framtida referenser.

⇒ Kundservice

För rådgivning av montering eller byte av delar – vänligen kontakta oss via e-mail eller telefon (nummer finns på förstasidan).

Ytterligare information finns på producentens hemsida: www.palramapplications.com

⇒ Säkerhetsföreskrifter

- Följ monteringsanvisningarna i den ordning som anvisas i instruktionerna, hoppa inte över något steg.
- Vi rekommenderar att handskar, skor och skyddsglasögon alltid används då man arbetar med metallprofiler.
- Vid användning av stege, redskap och bormaskin, följ tillverkarens säkerhetsråd.
- Var noga med att inte komma i kontakt med elkablar då metallprofiler hanteras.
- Undvik att montera växthuset i dåligt, blåsigt väder eller regn.
- Ta väl hand om all plastpåsar och se till att de är utom räckhåll för barn.
- Låt inte barn vistas på monteringsplatsen och håll omgivningen snygg.
- Luta eller tryck inte på växthuset under montering.
- Välj omsorgsfullt platsen för växthuset så att det inte påfrestas av kraftig vind eller extra snö.
- Försök inte att sätta ihop denna produkt om du är trött, har tagit droger, druckit alkohol eller om du brukar ha yrselattacker.
- Heta föremål som en nyligen använd grill, blåslampa eller dylikt får inte förvaras i växthuset. Försäkra att det inte finns några dolda rör eller kablar i marken innan du slår ner metallfästena för att förankra växthuset.
- Denna produkt är endast avsedd för att användas som växthus.

⇒ Underhåll & skötsel

När växthuset behöver rengöras skall du använda ett mildt rengöringsmedel och skölja rikligt med kallt och rent vatten.

Använd inte aceton, slipande rengöringsmedel eller andra specialmedel för att rengöra panelerna. Vi rekommenderar att man tidvis kontrollerar takpanelernas fäste (även plastfästen 329 och profiler 981) och försäkrar deras rätta position.

⇒ Verktyg & redskap

- Måttband
- Handskar
- Silikonspray
- Krysskruvmejsel
- Stege
- Drill bit
- Hammare (stor)

- Sax
- Skiftnyckel
- T001 verktyg (inkl. förpackningen)



⇒ Före montering

Detta är ett monteringsarbete som bäst utförs av min. två personer. Reservera åtminstone en halv dag för monteringsprocessen. Före monteringen bör grunden vara välgjord på den valda platsen.

Försäkra att grundens mått passar ihop med växthuset sockelmått. Vid val av växthuset positionering bör grunden vara rak. Välj en solig plats fri från skuggande träd och grenar. Is och snö från träd, grenar eller byggnader samt vindiga platser bör undvikas. Växthuset bör fästas stadigt i grunden med tillhörande metallsockel.

Metallsockeln har färdiga fästpositioner. Börja med att tömma förpackningen och försäkra att

alla delar finns – kontrollera innehållsförteckningen att delarna är korrekt märkta samt att de finns i rätt mängd.

Håll alla delar nära dig vid monteringen. Förvara alla smådelar (skruvar, muttrar o.s.v.) i en skål så att de inte tappas bort. Alla delar är märkta med nummer och bör användas.

I några profiler kan fästen bli oanvända p.g.a produktionstekniska grunder.

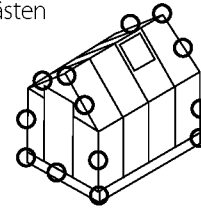

⇒ Under monteringen

Utför montering i den ordning som anges i instruktionerna.

Du kan använda silikonsprayen som hjälp för att glida profilerna på kopplingarna.

Spraya inte polykarbonatpanelerna.

Använd gummihammare om det behövs.



Steg 1: Försäkra att underlaget är plant, och vågrätt samt diagonalt.

Steg 5: Delarna A994 och A995 tillhör växthuset bakre vägg. Vid montering av dessa delar bestämmer du sida för dörren, se punkt 8.

Steg 8, 10, 15: Sidostödets A256 ovala hål bör monteras ner.

Montering av dörr (Steg 9, 56-62)

Dörrens öppningsriktning kan väljas. Denna instruktion följer höger öppningsriktning.

Steg 9: Bestäm öppningsriktningen. Profil 987 är gångjärnssidan.

Steg 56-62: Dörrens montering följer vald riktning.

Steg 42: Bestäm takluckans position. Takluckan kan installeras enligt punkt 30 men bör helst inte riktas mot solen (söder – sydväst).

Steg 55: Om fönstret inte stängs ordentligt, lossa skruvarna, justera profilen och dra åt skruvarna.

Steg 68: Försäkra ett stadigt fäste av basen i underlaget när monteringen är färdig.

Dra åt alla skruvar när du slutför monteringen.

Skruv 411 och mutter 412 används genom hela monteringsprocessen.

- Skruv 411 ska monteras från utsidan och mutter 412 från växthuset insida.
- Om inte annat anges, dra inte åt skruv och mutter (411 och 412) mer än 2-3 varv. Dra inte åt dem förrän monteringen av panelerna är avslutad. Dessa två ikoner anger om du behöver dra åt skruv eller inte.
- Tillfällig åtdragning kan i vissa steg behövas för att förhindra en profil från att falla tills den är fullt ansluten i kommande steg.



ВНИМАНИЕ!

Прежде чем приступить к сборке парника, пожалуйста, внимательно прочитайте настоящую инструкцию. Храните эту инструкцию в надежном месте для использования в будущем.

⇒ Служба технической поддержки

Для того, чтобы получить помощь при сборке, или для получения запасных частей – пожалуйста, зарегистрируйтесь на нашем сайте или позвоните на нашу службу технической поддержки (номер указан на титульном листе).

Дополнительную информацию Вы можете получить на нашем сайте:

www.palramapplications.com

⇒ Техника безопасности

- Крайне важно монтировать все компоненты в соответствии с указаниями.
- Не пропускайте ни один из этапов сборки.
- При сборке настоятельно рекомендуется использовать перчатки.
- Всегда надевайте обувь и защитные очки при работе с экструдированным алюминием.
- Если Вы пользуетесь лестницей или электроинструментами, обязательно следуйте инструкциям изготовителя по технике безопасности.
- Не допускайте соприкосновения наружных силовых кабелей с алюминиевыми профилями.
- Не пытайтесь монтировать парник в ветреную погоду или при влажных погодных условиях.
- Размещайте все пластиковые мешки в безопасном месте, храните их в недоступном для детей месте.
- Не пускайте детей на монтажную площадку.
- Не прислоняйтесь и не давите на парниковые конструкции во время сборки.
- Не размещайте Ваш парник в местах, подверженных воздействию сильного ветра.
- Не пытайтесь собирать парник, если вы устали, приняли лекарство или алкоголь, или если Вы подвержены приступам головокружения.
- Горячие предметы, такие как недавно использованные грили, паяльные лампы и т.д., не должны храниться в парнике. Прежде, чем вбивать колышки, убедитесь в том, что в земле нет скрытых труб или кабелей.
- Этот продукт предназначен для использования только в качестве парника.

⇒ Уход и обслуживание

Когда Вашему парнику потребуется чистка, воспользуйтесь слабым раствором моющего средства, а потом промойте его холодной чистой водой. НЕ ИСПОЛЬЗОВАТЬ ацетон, абразивные чистящие средства или другие специальные моющие средства для очистки панелей. Рекомендуется периодически проверять, что крышки кровельных панелей (пластиковая часть 329 и профиль 981) установлены на местах.

⇒ Инструменты и оборудование

- | | |
|----------------------|-------------------|
| • Рулетка | • Сверло |
| • Рабочие перчатки | • Большой молоток |
| • Смазочный материал | • Ножницы |
| • Отвертка Phillips | • Гаечный ключ |
| • Стремянка | • T001 |

**⇒ Перед монтажом**

Предпочтительно, чтобы эту сложную сборку выполняли два человека. Для процесса сборки выделите, по крайней мере, половину дня.

Выберите место для установки парника, он должен располагаться и закрепляться на плоской поверхности.

Выберите солнечное место вдали от нависающих деревьев.

Мы настоятельно рекомендуем, чтобы Вы установили свой парник непосредственно на твердом бетонном фундаменте. Когда будете выполнять работы, используйте предварительно просверленные отверстия в прилагаемой металлической основе.

Выньте все комплектующие из пакетов.

Рассортируйте комплектующие и проверьте содержимое всех пакетов по списку комплектующих деталей.

Во время сборки, комплектующие должны находиться под рукой. Храните мелкие детали (винты и т.д.) в чашке, чтобы они не потерялись.

Для облегчения идентификации комплектующих и правильного выполнения процесса сборки, все помещаемые профили используются в данном парнике. В результате некоторые отверстия в профилях не задействованы в процессе сборки.

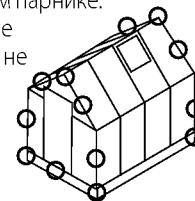

- Винты 411 и гайки 412 используются во время всего процесса сборки.
- Винты 411 должны быть в сборке с наружной стороны парника, а гайки располагаться во внутренней части парника.
- Не закрепляйте винты и гайки (411 и 412) более чем на 23- оборота. Не затягивайте их до завершения сборки панелей, если нет иных указаний.
- Однако, на некоторых этапах, временное полное затягивание нескольких винтов может быть необходимо для предотвращения падения профиля, это необходимо до тех пор, пока он не будет полностью соединен к конструкциям в следующих этапах.

⇒ Процесс сборки

Провести поэтапную сборку в соответствии с порядком действий, указанным в данной инструкции. Вы можете использовать спрей Силиконовая смазка для того, чтобы помочь вам скользить профилей на разъемах.

Не распыляйте Поликарбонатные панели. Используйте резиновые Мале, если необходимо.



Этап 1: убедитесь в том, что пол каркаса имеет форму квадрата путем измерения по диагонали и выравнивания с помощью спиртового ватерпаса.

Этап 5: Части A994, A995 находятся в задней части парника. Их закрепление влияет на переднюю часть парника.

Этапы 8, 10, 15: Овальное отверстие на поперечных перекладинах A256 всегда должно быть прикреплено к основанию парника.

Сборка дверей (Этапы 9, 56-62)

Дверь может устанавливаться с левой или с правой стороны, по Вашему желанию. В нашей инструкции показано, как устанавливается дверь с правой стороны.

Этап 9: Определите направление открывания двери на дверном косяке 987 в том месте, где будут расположены дверные петли.

Этапы 56-62: Сборка двери должна производиться в соответствии с этим решением.

Сборка дверей (Этапы 42, 55)

Этап 42: Определите места расположения окна перед сборкой. Окно может быть установлено в соответствии с одним из указанных вариантов.

Этап 55 В случае, если окна не закрыты, пожалуйста, отпустите винты, настройте профиль и затяните винт.

Этап 68: Надежно закрепите парник на позиции конечной позиции сразу же после завершения сборки. Затяните все винты при завершении сборки.

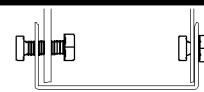

WAŻNE

Proszę przeczytać uważnie niniejszą instrukcję zanim przystąpisz do montażu szklarni. Przechowuj niniejszą instrukcję w bezpiecznym miejscu w celu późniejszego użycia.

⇒ Obsługa Klienta

W celu uzyskania dodatkowych informacji oraz w sprawie części zamiennych proszę odwiedzić naszą stronę www.palramapplications.com albo skontaktuj się z naszą telefoniczną linią serwisową podaną na dole strony.

⇒ Zalecenia Bezpieczeństwa

- Wykonuj poszczególne kroki montażu w kolejności wskazanej w instrukcjach. Nie pomijaj żadnego kroku.
- Zalecamy używanie rękawic roboczych podczas montażu.
- Zawsze miej założone obuwie oraz okulary ochronne podczas pracy z tłoczonym aluminium.
- Używając drabiny lub narzędzi elektrycznych stosuj się do zaleceń bezpieczeństwa ich producentów.
- Nie dotykaj napowietrznych przewodów elektrycznych profilami aluminiowymi.
- Nie próbuj montażu szklarni w wietrznych lub deszczowych warunkach pogodowych.
- W bezpieczny sposób pozbądź się wszystkich plastikowych opakowań – trzymaj je poza zasięgiem małych dzieci.
- Trzymaj dzieci z dala od miejsca montażu.
- Nie opieraj się ani nie popychaj szklarni w trakcie montażu.
- Nie umieszczaj Twojej szklarni w miejscu wyeksponowanym na nadmierny wiatr.
- Nie podejmuj montażu szklarni gdy jesteś zmęczony, zażywałeś narkotyki, alkohol lub cierpisz na zawroty głowy.
- Gorące przedmioty, takie jak niedawno używany grill, palniki powinny być trzymane z dala od ścian szklarni.
- Jeśli będziesz chciał zamocować szklarnię bezpośrednio do betonu upewnij się że w podłożu nie znajdują się ukryte rury lub przewody zanim zamocujesz kołki.
- Ten produkt powstał do wykorzystania tylko jako szklarnia.

⇒ Pielęgnacja i konserwacja

Kiedy Twoja szklarnia wymaga czyszczenia, używaj roztworu łagodnych detergentów a następnie spłucz zimną, czystą wodą. Do czyszczenia przezroczystych paneli nie używaj acetonu, ściernych substancji lub innych specjalnych detergentów.

⇒ Sprzęt i narzędzia

- miarka taśmowa
- rękawice robocze
- plastikowy lub gumowy młotek
- smar
- śrubokręt krzyżakowy
- drabina schodowa

- wiertło
- duży młotek
- nożyczki
- klucz
- T001

**⇒ Wskazówki ogólne przed złożeniem**

Ten wieloczęściowy montaż przebiega najsprawniej z udziałem dwóch osób. Przeznacz przynajmniej pół dnia na montaż.

Wybór miejsca - szklarnia musi być umieszczona, wypoziomowana oraz zamocowana na płaskiej, równej nawierzchni.

Wybierz miejsce nasłonecznione, z dala od nawisających drzew. Zalecamy aby szklarnia była przykręcona do betonowej podstawy lub płyt. Jeśli montujesz szklarnię bezpośrednio do betonowych fundamentów użyj nawierconych otworów w dostarczonej metalowej bazie. Wyjmij wszystkie części z opakowań. Posortuj je i sprawdź z listą załączonych części.

Części składowe powinny być sprawdzone i ułożone w zasięgu ręki. Trzymaj wszystkie małe części (śruby etc.) w pojemniku tak aby nie zginęły.

W celu ułatwienia identyfikacji części oraz całości procesu montażu wszystkie profile zostaną użyte w szklarni. Jedynie niektóre uszczelnienia do profili mogą zostać finalnie nie użyte podczas montażu.

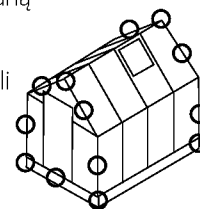
**Śruby 411 oraz nakrętki 412 są użyte w całości montażu**

- Śruby 411 używamy od zewnątrz, nakrętki 412 nakładamy od wewnętrznej strony szklarni.
- Nie dokręcaj śrub i nakrętek (411 i 412) wykonując więcej niż 2-3 obroty. Nie dokręcaj ostatecznie jeśli całość paneli nie jest złożona.
- Jednakże, w niektórych krokach tymczasowe mocniejsze dokręcenie kilku śrub zapobiegnie upadkowi profili zanim będą one całkowicie i mocno połączone w następnych krokach.

⇒ Montaż

Kroki montażowe przeprowadzaj w podanej kolejności.

Możesz użyć smaru w sprayu Krzemowej w celu pomóc wsunąć profile na złączach. Nie rozpylać paneli poliwęglanowych. Użyj Malet gumową razie potrzeby.



Krok 1: Upewnij się, że podstawa jest kwadratowa, przez zmierzenie przekątnych i wypoziomowanie, przy użyciu poziomicy.

Krok 5: Części A994, A995 są na tylnej części szklarni. Zamocowanie ich wyznacza przód szklarni.

Kroki 8, 10, 15: Owalne otwory w poprzeczkach A256 powinny być przyłączone do podstawy szklarni.

Montaż drzwi (kroki 9, 56-62)

Drzwi, zależnie od decyzji składającego, mogą być otwierane na prawo lub lewo. Instrukcja pokazuje montaż drzwi dla osoby praworęcznej.

Krok 9: wyznaczenie kierunku drzwi Miejsce 987 to miejsce w którym zakładamy zawiasy.

Kroki 56-62: Montaż drzwi powinien odbyć się zgodnie z tą decyzją.

Krok 42: Zdecyduj o położeniu okien przed złożeniem. Okno może być zainstalowane w jednej ze wskazanych opcji.

Krok 55: W przypadku okno nie jest zamknięte, proszę zwolnij śruby, ustawić profil i dokręcić śrubę.

Krok 68: Połącz mocno szklarnię w ostatecznej pozycji, zaraz po zakończeniu całości montażu.

Dokręć wszystkie śruby po zakończeniu montażu.

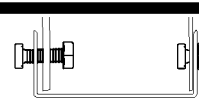

SVARĪGI

Lūdzu, uzmanīgi izlasiet šo instrukciju pirms siltumnīcas uzstādīšanas. Saglabājiet šo instrukciju drošā vietā turpmākai nepieciešamībai.

⇒ Klientu apkalpošana

Lai saņemtu palīdzību saistībā ar montāžu vai sastāvdaļu maiņu – lūdzu, reģistrējieties mūsu mājaslapā vai zvaniet uz apkalpošanas līniju (tālruna numurs norādīts titullapā).

Papildus informāciju variet atrast mūsu mājaslapā: www.palramapplications.com

⇒ Padomi drošībai

- Ir ļoti svarīgi uzstādīt visas detaļas pēc norādījumiem. Neizlaidiet nevienu soli.
- Mēs dziļi iesakām uzvilkt cimdus montāžas laikā.
- Vienmēr nēsājiet apavus un drošības brilles, kad rīkojieties ar presētu alumīniju.
- Ja izmantojiet saliekamās kāpnes vai ar elektrību darbināmus instrumentus pārliecinieties, ka ievērojat ražotāja dotos padomus par drošību.
- Neaizskariet virs galvas esošus elektrības vadus ar alumīnija profiliem.
- Nemēģiniet uzstādīt siltumnīcu vējainos vai mitros laikapstākļos.
- Atbrīvojieties no visiem plastikāta iesaiņojumiem droši un glabājiet tos maziem bērniem nepieejamās vietās.
- Nelaidiet bērnus montāžas vietā.
- Neatbalstieties un nestumiet siltumnīcu montāžas laikā.
- Nenovietojiet siltumnīcu vietās, kas pakļautas pārmērīgi vējainiem laika apstākļiem.
- Nemēģiniet uzstādīt siltumnīcu, ja esiet noguris, lietojis kādus medikamentus vai alkoholu vai gadījumā, ja esiet ar tieksmi uz reibuma mirkļiem.
- Karsti priekšmeti, piemēram, nesen izmantoti grili, lodlampas u.tml. priekšmeti, nedrīkst tikt uzglabāti siltumnīcā. Pārliecinieties, ka zemē neatrodas apslēptas caurules vai elektrības vadi pirms ievietojiet tapas.
- Šis produkts ir paredzēts izmantošanai tikai kā siltumnīca.

⇒ Kopšana un uzturēšana

Kad siltumnīcu nepieciešams notīrīt, izmantojiet vieglu mazgāšanas līdzekli un noskalojiet ar vēsu, tīru ūdeni. NEIZMANTOJIET acetonu, abrazīvu tīrītāju vai citus īpašus tīrīšanas līdzekļus, lai notīrītu caurspīdīgos paneļus. Ir ieteicams periodiski pārbaudīt, vai jumta paneli > uznavas (plastmasas daļa 329 un profils 981) ir savās vietās.

⇒ Instrumenti un aprīkojums

- Mērlente
- Darba cimds
- Smērvielā
- Phillips skrūvgriezis
- Saliekamās kāpnes
- Urbis
- Liels āmurs

- Šķēres
- Uzgrīzņu atslēga
- T001

**⇒ Pirms montāžas**

Šis ir daudzu detaļu montāža, kuru vislabāk veikt divām personām. Veltiet apmēram pusi dienas montāžas procesam.

Vietas izvēle – siltumnīcu ir jānovieto un jāpiestiprina uz platas, līdzenas virsmas. Izvēlieties saulainu vietu, kas būtu tālāk nost no kokiem.

Mēs Jums dziļi iesakām piestiprināt siltumnīcu tieši pie cieta betona pamata. To darot, izmantojiet iepriekš izurbtos caurumus metāla pamatnē, kas pievienota komplektam.

Izņemiet visas sastāvdaļas no iepakojuma. Sašķirojiet detaļas un pārbaudiet pēc sastāvdaļu saraksta.

Montāžas laikā detaļām ir jābūt tuvu pie rokas. Turiet visas sīkās detaļas (skrūves u.tml.) blīdā, lai tās nepazūd.

Lai veicinātu detaļu atpazīšanu un montāžas procesu, visi komplektā ietvertie profili tiek izmantoti siltumnīcas būvē. Tā rezultātā dažas ailes profilos netiek izmantotas montāžas laikā.

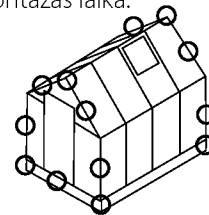
**⇒ Montāžas laikā**

Veikt montāžas soļus noteiktajā kārtībā instrukcijās.

Jūs varat izmantot Silicon smērvielu aerosolu, lai palīdzētu jums slaidu profilus uz savienotājiem. Neizsmidzināt Polikarbonāta paneļi. Izmantojiet gumijas malet ja nepieciešams.



1. solis: Pārliecinieties, ka pamatne ir kvadrātveida, izmērot diagonāles un nosakiet līmeni, izmantojot līmeņrādi.

5. solis: A994, A995 detaļas ir siltumnīcas aizmugurē. To piestiprināšana nosaka siltumnīcas priekšpusi.

8., 10., 15. solis: Ovālie caurumi restēs A256 vienmēr ir jāuzstāda siltumnīcas pamatnē.

Durvju montāža (9., 56.-62. solis,)

Durvis var tikt uzstādītas, lai tās vērtos, gan uz labo, gan kreiso pusi. Šī instrukcija norāda montāžu durvīm, kas veras uz labo pusi.

9. solis: nosaka durvju virzienu, durvju vieta 987 ir vieta, kurā atradīsies eņģes.

56.-62. solis: Durvju montāža ir jāveic saskaņā ar šo lēmumu.

Durvju loga (42., 55. solis,)

42. solis: Izlemiet par loga atrašanās vietu pirms montāžas uzsākšanas. Logs var atrasties vienā no norādītajām vietām.

55. solis: Gadījumā logs nav kārtīgi aizvērts, lūdzu atbrīvojot skrūves, pielāgot profilu un nostipriniet skrūvi.

68. solis: Stingri pievienojiet siltumnīcu, lai noteiktu līmeni gala pozīcijai uzreiz pēc montāžas veikšanas.

Pivelciet visas skrūves, aizpildot montāžu.

• Skrūves 411 un uznavas 412 tiek izmantotas visā montāžas procesa laikā.

- Skrūves 411 ir jāuzstāda no siltumnīcas ārpusē un uznavas 412 - no iekšpusē.
 - Nepivelciet skrūves un uznavas (411 un 412) ciešāk kā 23- apgriezieni. Nepivelciet tās līdz paneļa montāžas pabeigšanai, ja nav norādīts citādi.
- Tomēr dažos soļos, dažu skrūvju pagaidu pievilksana var būt nepieciešama, lai aizkavētu profilu no krišanas, līdz tas tiks pilnībā pievienots nākamajos soļos.



IMPORTANTE

Si invita a leggere attentamente le seguenti istruzioni prima di iniziare il montaggio della serra. Conservare queste istruzioni in luogo sicuro per futuro riferimento.

⇒ **Servizio Assistenza Clienti:**

Per assistenza nel montaggio o nelle parti di ricambio – si invita a visitare il nostro sito web o a chiamare la nostra linea di servizio (il numero si trova sulla pagina principale).

Ulteriori informazioni sono reperibili sul nostro sito web: www.palramapplications.com

⇒ **Nota sulla sicurezza**

- È di grande importanza montare le parti secondo le direttive. Non omettere alcuna fase.
- Raccomandiamo caldamente l'uso dei guanti di lavoro durante i lavori di montaggio.
- Indossare sempre scarpe ed occhiali di sicurezza nel maneggiare i profili di alluminio estruso.
- Usando una scala a pioli o utensili elettrici da lavoro, assicurarsi di seguire le disposizioni di sicurezza fornite dal produttore.
- Non toccare cavi elettrici con i profili d'alluminio.
- Non tentare di montare la serra in condizioni atmosferiche ventose o umide.
- Eliminare in modo sicuro tutti i sacchetti di plastica – conservarli fuori della portata dei bambini.
- Tenere i bambini a distanza dall'area di montaggio.
- Non appoggiarsi o spingere la serra durante la sua costruzione.
- Non posizionare la serra in un'area troppo esposta al vento.
- Non tentare di montare la serra in condizioni di stanchezza, dopo aver fatto uso di stupefacenti o alcolici o se si è soggetti ad avere capogiri.
- Oggetti roventi quali griglie o bruciatori per saldature usati di recente ecc., non devono essere introdotti nella serra. Verificare che non vi siano tubi o cavi elettrici sotterranei prima di conficcare i paletti.
- Questo prodotto è stato progettato per essere adibito esclusivamente a serra.

⇒ **Cura e manutenzione**

Quando la serra deve essere pulita, usare una soluzione detergente neutra e sciacquare con acqua fredda pulita. NON usare acetone, materiali abrasivi o altri detergenti speciali per la pulizia dei pannelli trasparenti. È raccomandabile verificare periodicamente che i coperchi dei pannelli del tetto (parti in plastica 329 e profilo 981) siano montati al loro posto.

⇒ **Utensili ed Attrezzature**

- Metro
- Guanti da lavoro
- Lubrificante
- Cacciavite con punta a croce
- Scala a pioli
- Punta da trapano

- Martello pesante
- Chiave fissa
- T001 - Utensile speciale per viti 411 e dadi 412

⇒ **Prima del montaggio**

Il montaggio delle parti dovrà essere eseguito preferibilmente da due persone. Va tenuto conto di almeno mezza giornata per completare la procedura di montaggio.

Selezione della posizione - La serra deve essere montata, posizionata e fissata su una superficie piana.

Scegliere una posizione esposta al sole che non si trovi sotto un albero.

Si raccomanda di ancorare saldamente la serra al terreno.

Si declina ogni responsabilità per eventuali danni arrecati a persone o cose a causa della serra trasportata dal vento.

Estrarre tutte le componenti dall'imballaggio.

Ordinare le parti e verificarle con l'elenco contenuto nella confezione.

Durante il montaggio le parti devono essere tenute a portata di mano.

Tenere tutte le parti piccole (come viti ecc.) in una vaschetta perché non vadano perse.

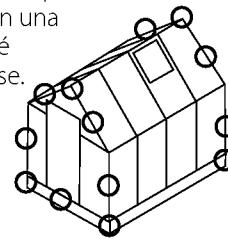
⇒ **Durante il montaggio**

Si invita ad eseguire le fasi di montaggio nell'ordine in cui sono descritte nelle istruzioni.

Si può usare spray lubrificante ai siliconi per far scivolare i profili sui connettori. Non usare lo spray sui pannelli di policarbonato.

Usare il martello di gomma se necessario.



Passo 1: Assicurare che la base sia quadrata misurandone le diagonali e portarla a livello usando una livella a bolla d'aria.

Passo 5: Le parti A994, A995 sono situate sul fondo della serra. Il loro fissaggio determina il lato anteriore della serra.

Passi 8, 10, 15: Il foro ovale delle traverse A256 deve sempre essere montato alla base della serra.

Montaggio della porta (Passi 9, 56 - 62)

La porta può essere montata a scelta con il battente a sinistra o a destra. In queste istruzioni si fa riferimento al battente sul lato destro della porta.

Passo 9: determina la direzione del battente della porta 987 dove si trovano i cardini della porta.

Passi 56 -62: Il montaggio della porta avviene secondo questa decisione.

Passo 42: Decidere la posizione della finestra prima del montaggio. La finestra può essere installata in una delle posizioni alternative indicate.

Passo 55: Nel caso in cui la finestra non si chiude correttamente, allentare le viti, regolare il profilo e stringere la vite.

Passo 68: Fissare fermamente la serra in una posizione finale piana a livella subito dopo aver completato il montaggio.

Serrare tutte le viti al momento di compilare il montaggio.

- Le viti 411 ed i dadi 412 sono usati in tutto il processo di montaggio.
- Le viti 411 devono essere inserite dall'esterno ed i dadi 412 dall'interno della serra.
- Non serrare le viti ed i dadi (411 e 412) più di 2-3 giri. Non serrare fino a montaggio completato dei pannelli, se non stabilito diversamente.
- Tuttavia, in alcuni passi, alcune viti devono essere serrate temporaneamente per prevenire che un profilo cada fino a che questo non sia collegato saldamente nei prossimi passi.



TÄHTIS

Palun lugege kasutusjuhised hoolikalt läbi enne kui hakkate oma kasvuhoonet kokku panema.

Hoidke need juhised turvalised kohas edaspidiseks kasutamiseks

⇒ **Klienditeenindus**

Abiks kokkupanemisel või varuosade jaoks – palun logige sisse meie veebilehele või helistage klienditeenindusse (number on tiitellehel).

Lisainformatsiooni võib leida meie veebilehelt: www.palramapplications.com

⇒ **Ohutusjuhised**

- Soovitame tungivalt kasutada kokkupanekul töökindaid.
- Kandke alati jalanõusid ja kaitseprille kui töötate pressitud alumiiniumiga.
- Kasutades redelit või elektritööriistu, veenduge, et järgite tootjapoolseid ohutusjuhiseid.
- Ärge katsuge üleulatuvaid elektrikaableid alumiiniumprofiiliga.
- Ärge üritage kasvuhoonet kokku panna tuulistes või niisketes tingimustes.
- Visake kõik plastikkotid ohutult ära, et hoida need eemal väikestest lastest.
- Hoidke lapsed kokkupanemisalast eemal.
- Ärge nõjatuge kasvuhoone vastu või lükake seda kokkupanekul.
- Ärge asetage oma kasvuhoonet kohta kus on tugev tuul.
- Ärge üritage kasvuhoonet kokku panna kui olete väsinud, kasutate ravimeid, olete tarbinud alkoholi või olete uimane.
- Kuuma esemed, nagu hiljuti kasutatud grill, leeklamp jm ei tohi hoida kasvuhoones. Veenduge, et varjatud torusid või kaablit poleks maapinnas enne vaiade sisestamist.
- See toode on mõeldud kasutamiseks ainult kasvuhoonena.

⇒ **Hooldus ja korrashoid**

Kui Teie kasvuhoone vajab puhastamist, kasutage pehmet puhastusvahendit ja loputage külma, puhta veega. ÄRGE KASUTAGE atsetooni, abrasiivseid puhastusaineid või teisi lahuseid paneelide puhastamiseks. On perioodiliselt soovitatav kontrollida, et katusepaneelide vahed (plastosad 329 ja profiil 981) oleksid omal kohal.

⇒ **Tööriistad ja varustus**

- Mõõdulint
- Töökindad
- Määrdeõli
- Ristpeaga kruvikeeraja
- Redel
- Puur
- Suur haamer

- Käärid
- Mutrivõti
- T001

⇒ **Enne kokkupanemist**

Seda mitmeosalist agregaatid saab kõige paremini kokku panna kahekesi. Võimaldage endale vähemalt pool päeva kokkupanekuks.

Valige koht – kasvuhoone peab olema asetatud ja paigaldatud tasasele pinnale

Valige päikeseline koht, eemal üleulatuvatest puudest.

Soovitame tungivalt kinnitada kasvuhoone otse betoonvundamendile. Seda tehakse kasutades eelnevalt puuritud auke metallalusel.

Võtke välja kõik osad pakendist. Sorteerige osad ja kontrollige sisu osade nimekirjaga.

Kokkupanekul peaksid kõik osad olema laotatud käeulatusse. Hoidke väikesed osad (kruvid jm) kausis, et nad ära ei kaoks.

Et hõlbustada osade eristamist ja kokkupanekut, on selles kasvuhoones kasutatud kõiki positsioneeritud profile. Tulemusena ei kasutata kõiki avausi profiilides, kokkupanekul.

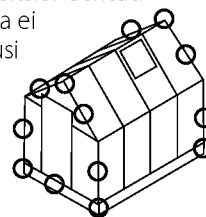

- **Kruvisid 411 ja mutreid 412 kasutatakse läbivalt kogu kokkupanemisprotsessi ajal.**
- Kruvid 411 tuleb monteerida väljastpoolt ja mutrid 412 seestpoolt kasvuhoonet.
- Ärge pinguldage kruvisid ja mutreid (411 ja 412) rohkem kui 23- korda. Ärge pinguldage neid kuni paneelide lõpliku kokkupanekuni, kui ei ole öeldud teisiti. Siiski, mõnedes etappides tuleb mõned kruvid ajutiselt fikseerida, et vältida profiili langemist kuni see on ühendatud järgmises etapis.

⇒ **Kokkupanemise ajal**

Täitke kokkupanemisetapid järjekorras, nagu juhistes on kirjas.

Võite kasutada Silicon Lubricant Spray, et aidata teil lükake profiilid pistikutega. Ärge pihustage polükarbonaadist paneelid. Kasutage kummi Malet kui vaja.



Etapp 1: Veenduge, et alus oleks ruudukujuline, mõõtes diagonaale ja loodis, kasutades vaaderpassi.

Etapp 5: Osad A994, A995 käivad kasvuhoone tagumisse osasse. Nende fikseerimisel määrate kindlaks kasvuhoone esimese külje.

Etapid 8, 10, 15: Ovaalne auk põikpuus A256 tuleb alati paigaldada kasvuhoone põhja.

Ukse kokkupanek (etapid 9, 56-62)

Ust saab paigaldada vasakukäelise või paremakäelise uksena, nagu soovite. Need juhised näitavad paremakäelise ukse kokkupanekut.

Etapp 9: Määrab kindlaks ukse suuna – uksepost 987 on seal kus asuvad ukse hinged.

Etapid 56-62: Ukse kokkupanek tuleb teha, järgides seda otsust.

Ukse akna (etapid 42, 55)

Etapp 42: Otsustage akna asukoht enne kokkupanekut. Akent saab paigaldada ühel näidatud võimalustest.

Etapp 55: Kui aken ei ole õigesti suletud, siis vabastage kruvid, kohandada profiili ja keerake kruvi kinni.

Etapp 68: Kinnitage kasvuhoone kindlalt tasasele pinnale pärast kokkupanekut.

Pingutage kõik kruvid täites koost.



Contents

Item	Inc./cm	Qty.
962	86 ¹ / ₄ / 219	2
961	66 ³ / ₄ / 170	4
972	70 ¹ / ₂ / 179	4
973	70 ¹ / ₂ / 179	2
287	70 / 178	1
996	46 / 117	8

Item	Inc./cm	Qty.
994	67 / 170	1
995	67 / 170	1
987	65 / 165	1
988	65 / 165	1
985	64 / 163	2
966	1570mm	2

Contents

Item	Inc./cm	Qty.
256	50 ³ / ₄ / 129	8

993	46 / 117	20
-----	----------	----

126	118 / 300	2
-----	-----------	---

3017	22 ³ / ₄ / 53	4
3016	64 / 163	1

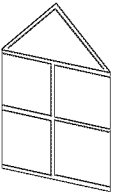
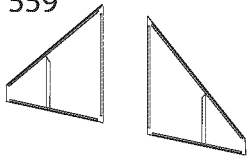
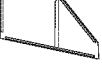
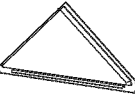
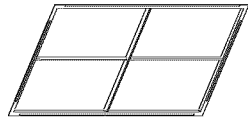
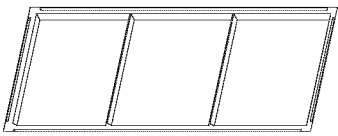
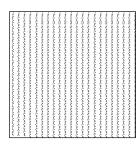
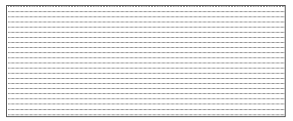
Item	Qty.
553 	1
559 	2
560 	2
570 	1
567 	2
7011 	17
586 	4
581 	10

Item	Inc./cm	Qty.
989	24 ¹ / ₄ / 61.5	2

991	24 ¹ / ₄ / 61.5	2
-----	---------------------------------------	---

992	22 ³ / ₄ / 58	4
-----	-------------------------------------	---

984	21 ¹ / ₂ / 55	2
-----	-------------------------------------	---

981	22 / 56	12
-----	---------	----

06		1
----	--	---

Item	Inc./cm	Qty.
286	24 / 60	2

999	22 / 56	5
-----	---------	---















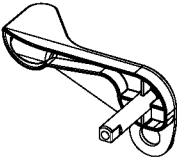

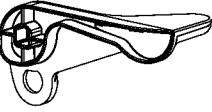

986	24 ³ / ₄ / 63	1
-----	-------------------------------------	---

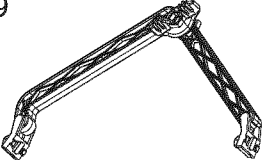
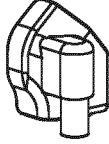
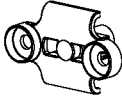
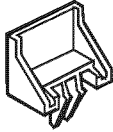
983	18 ¹ / ₂ / 47	1
-----	-------------------------------------	---

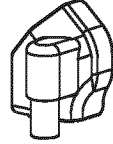
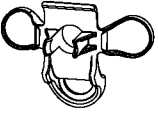
990	22 / 56	2
-----	---------	---

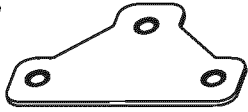
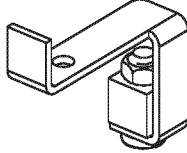
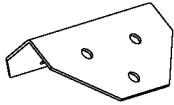
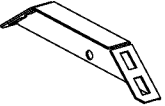
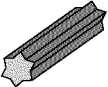
461 	13
spare	1

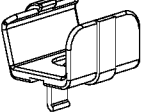
Contents

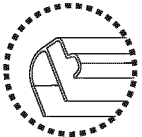
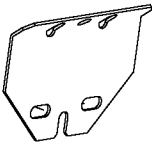
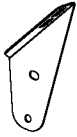
Item	Qty.	Item	Qty.	Item	Qty.	Item	Qty.	Item	Qty.
447	9	411	170	463	2	343	2	7083	1
	spare 1		spare 6						
4008	15	412	182	462	2	329	10	7084	1
	spare 1		spare 6		4				
4043	13	99	2	464	4	344L	2	7085	1
	spare 3			465	9				
328	35	22	4	422	9	344R	2	7086	1
	spare 1				spare 1				
M96	6	288	5	4037	1	07	1	7088	1
									
7009 (PVC)	5	T001	1	318 PVC	24	292	2	926	2
	spare 1				spare 2				
						08	2	456	2
									

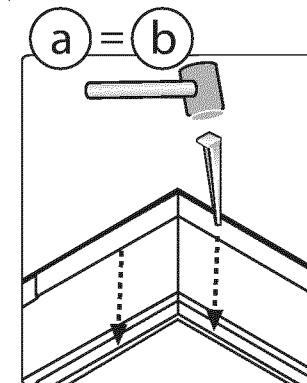
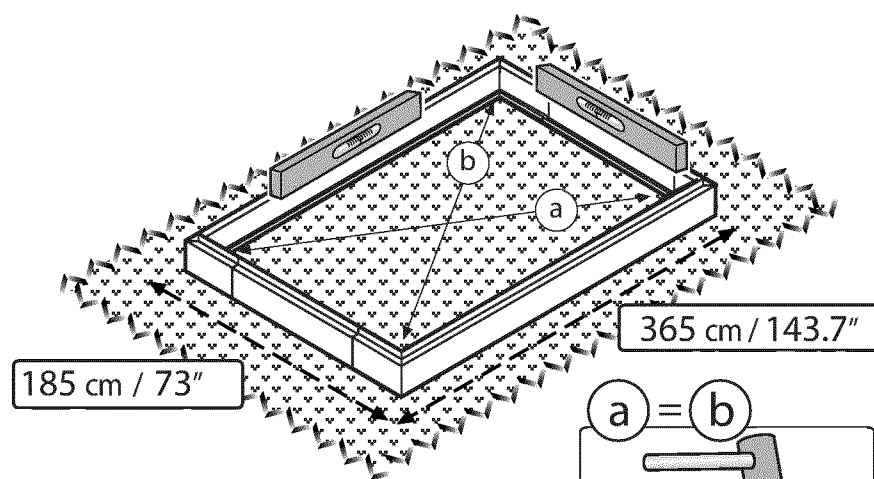
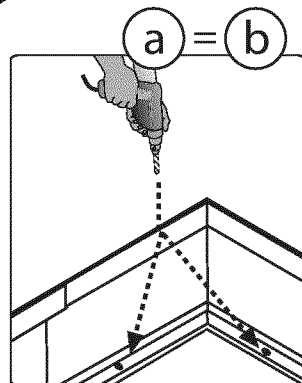
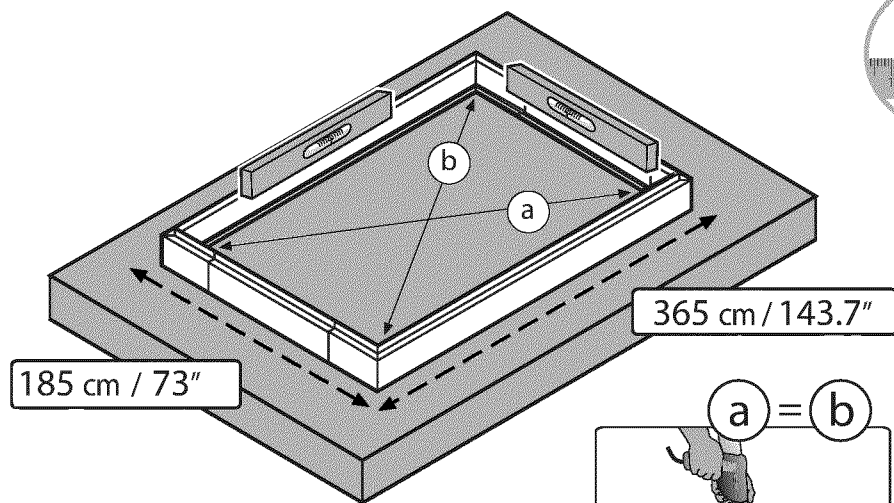
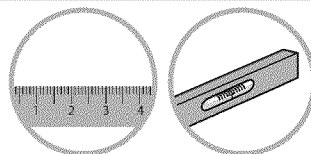
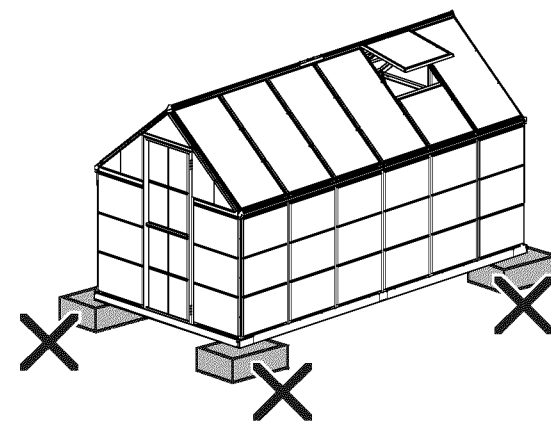
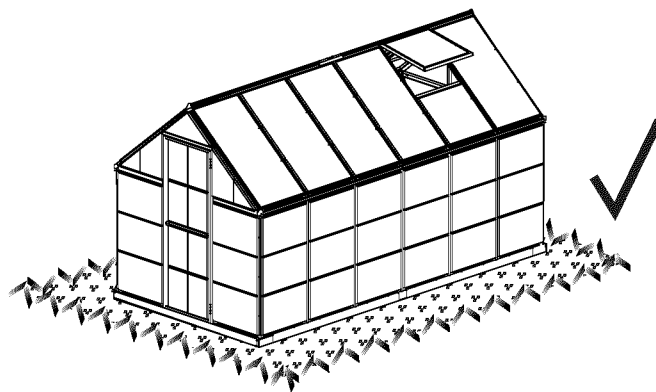
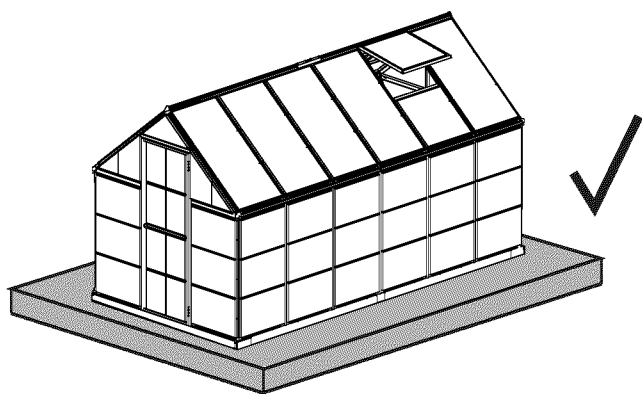

1

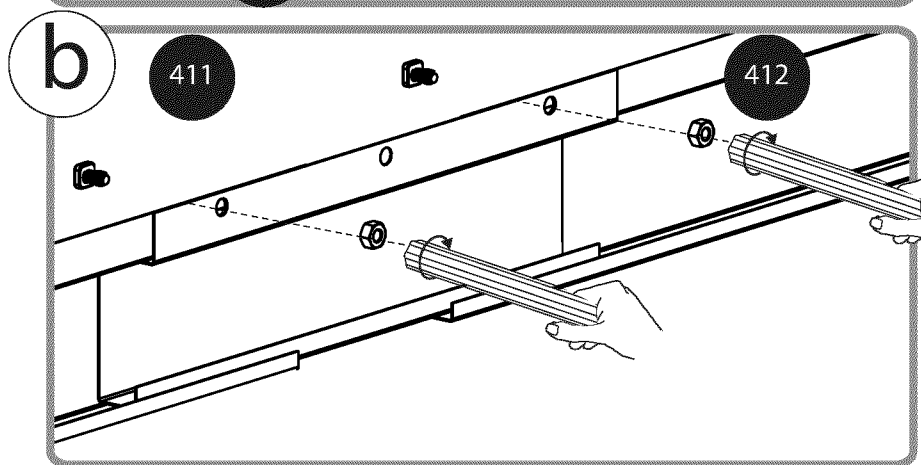
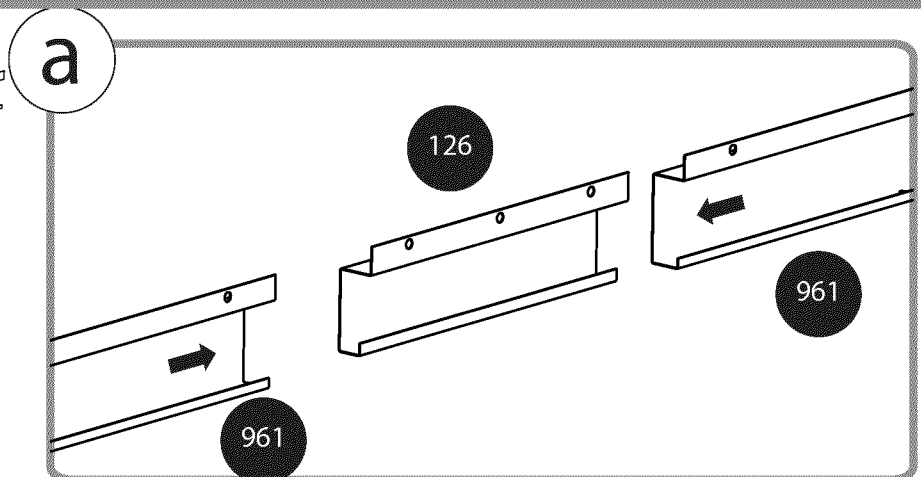
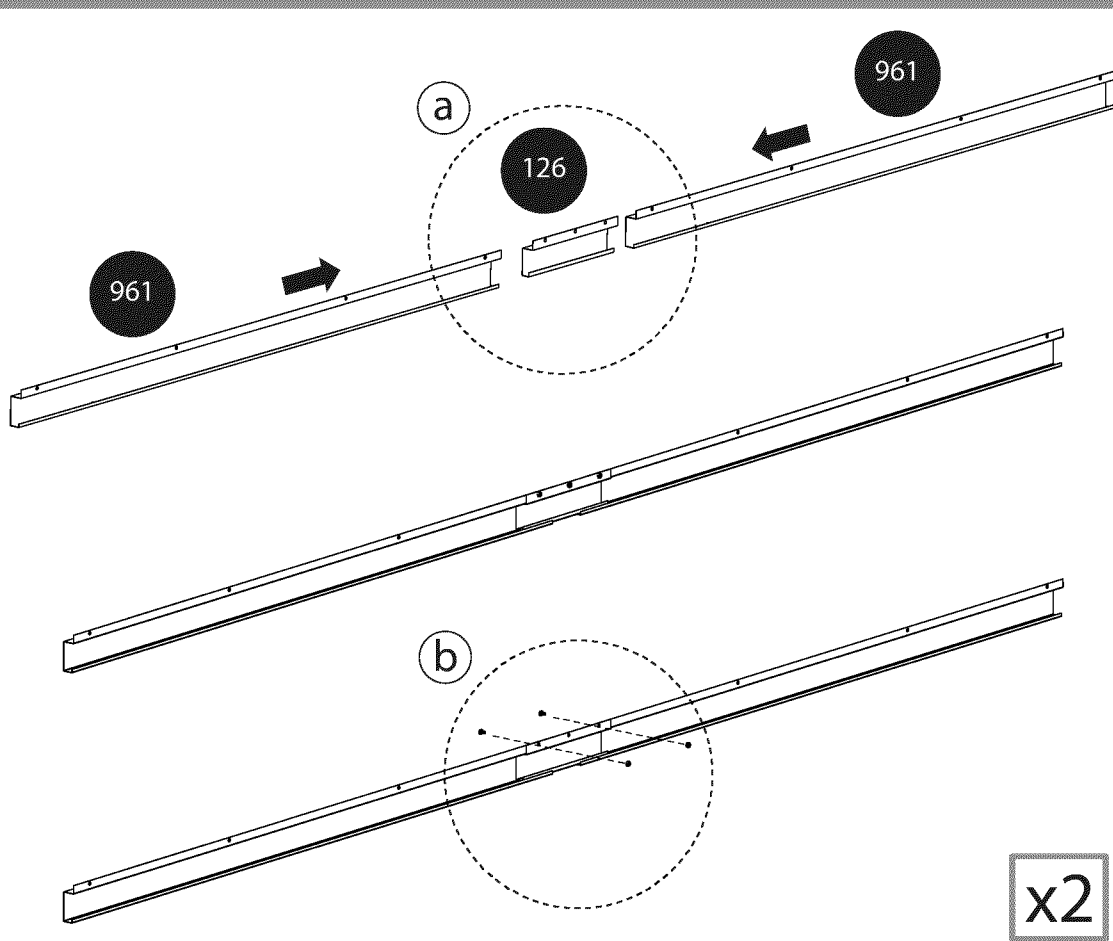
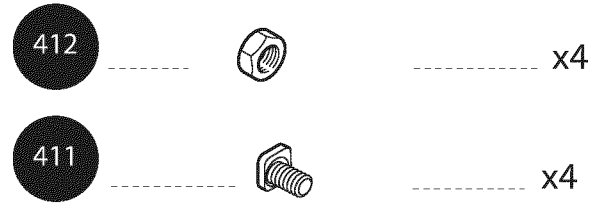
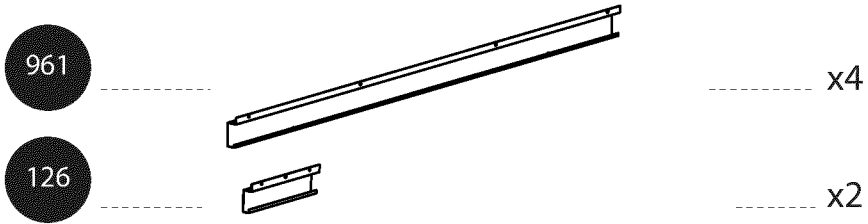
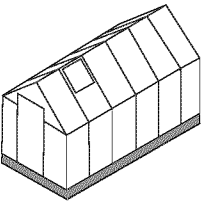

x2

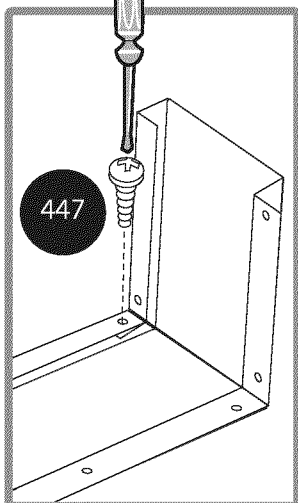
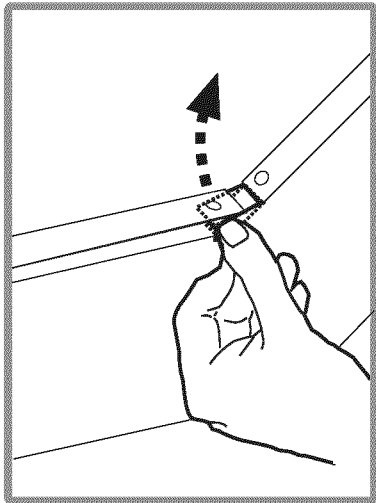
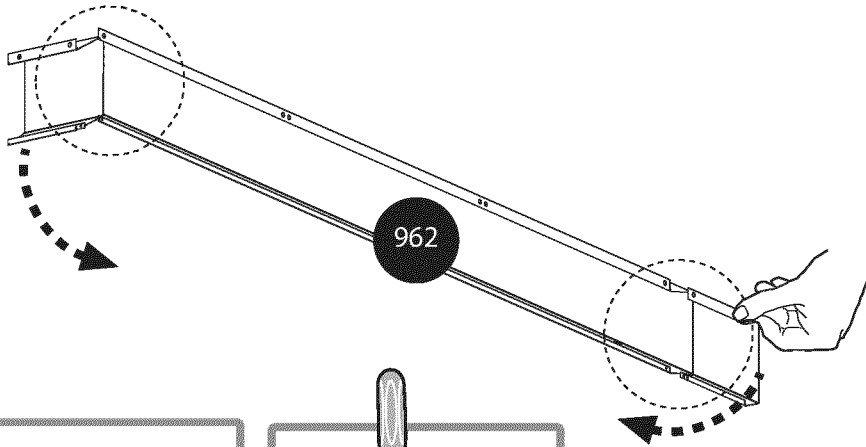
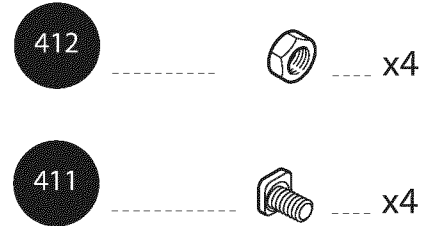
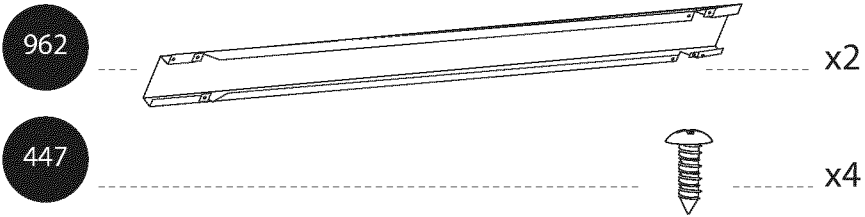
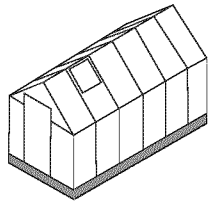

x2

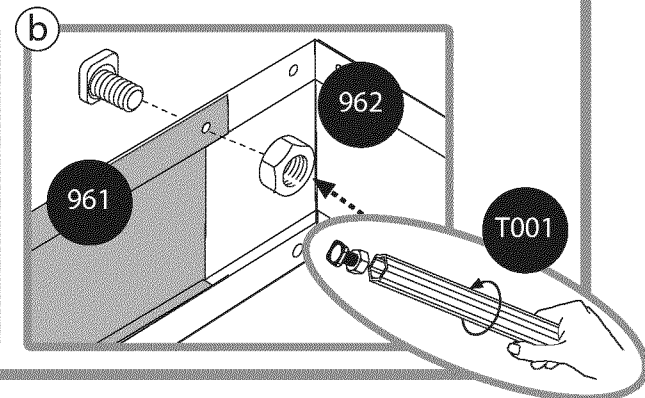
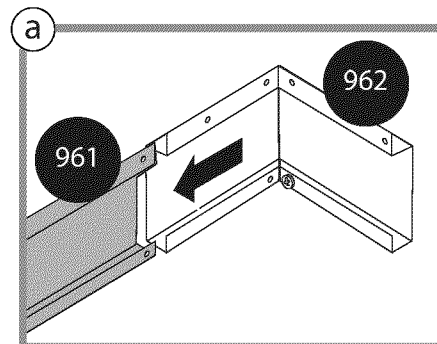
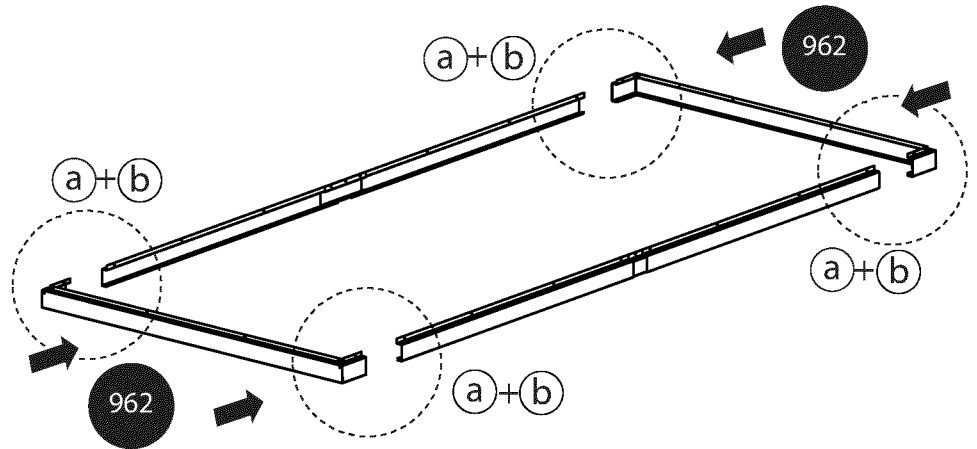

3

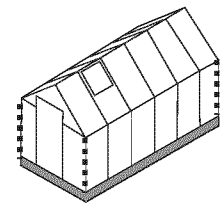

996

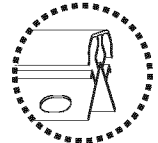

x4

412



x8

411



x8

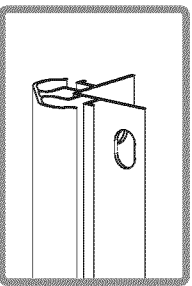
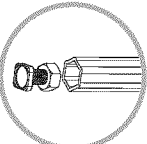

996

996

996

996

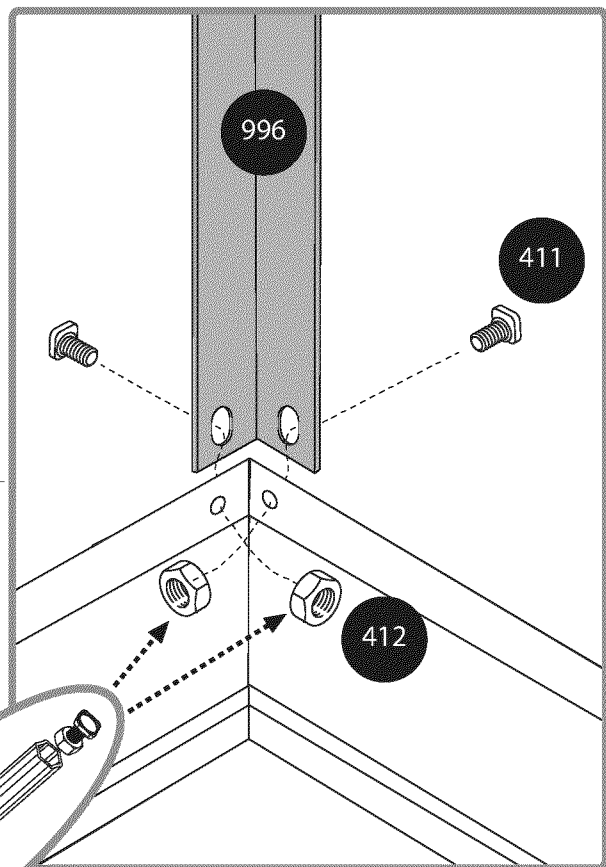
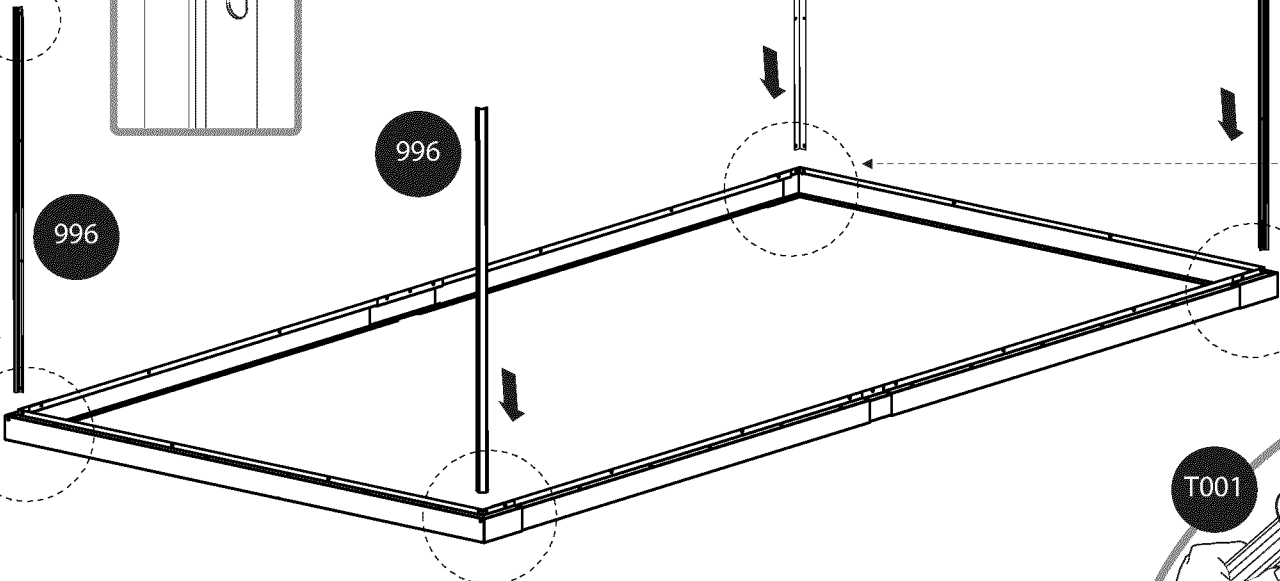

996

411

412

T001

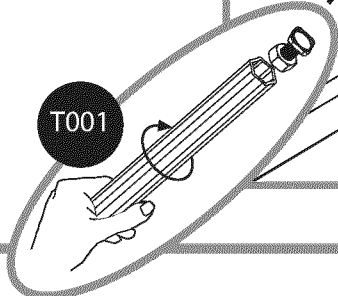

4

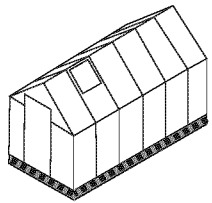

412  x14

411  x14

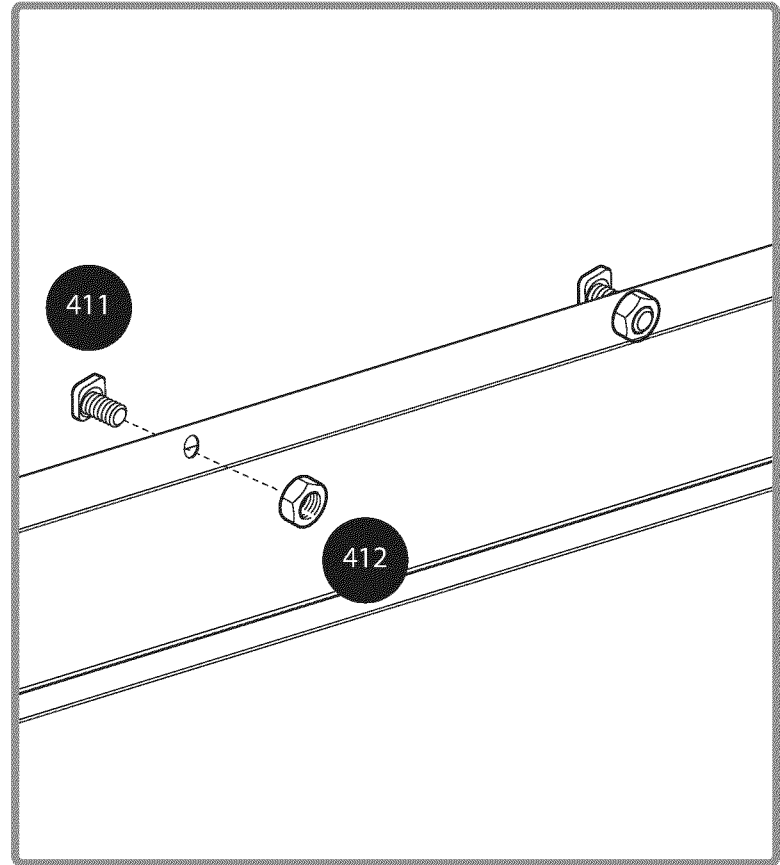
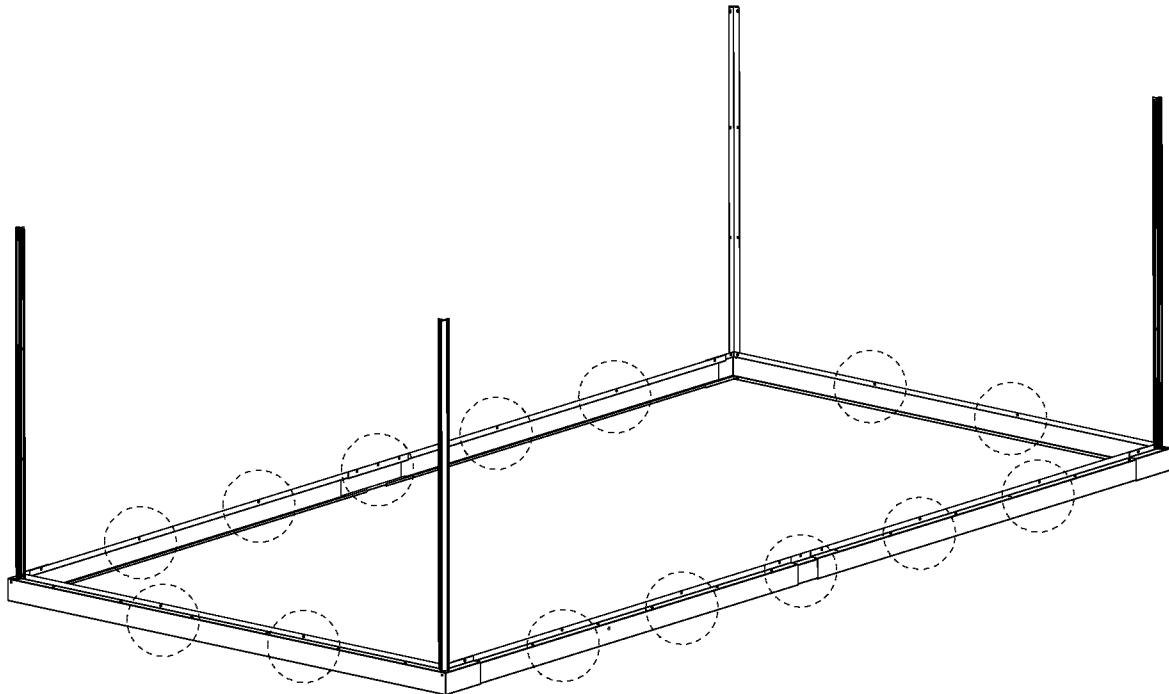

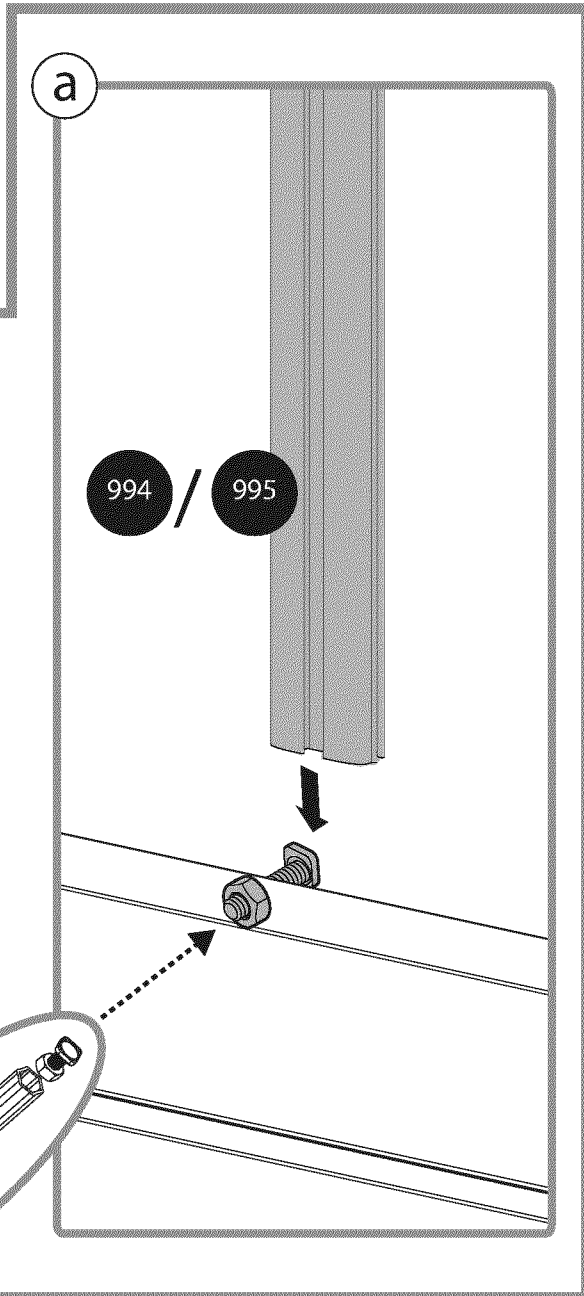
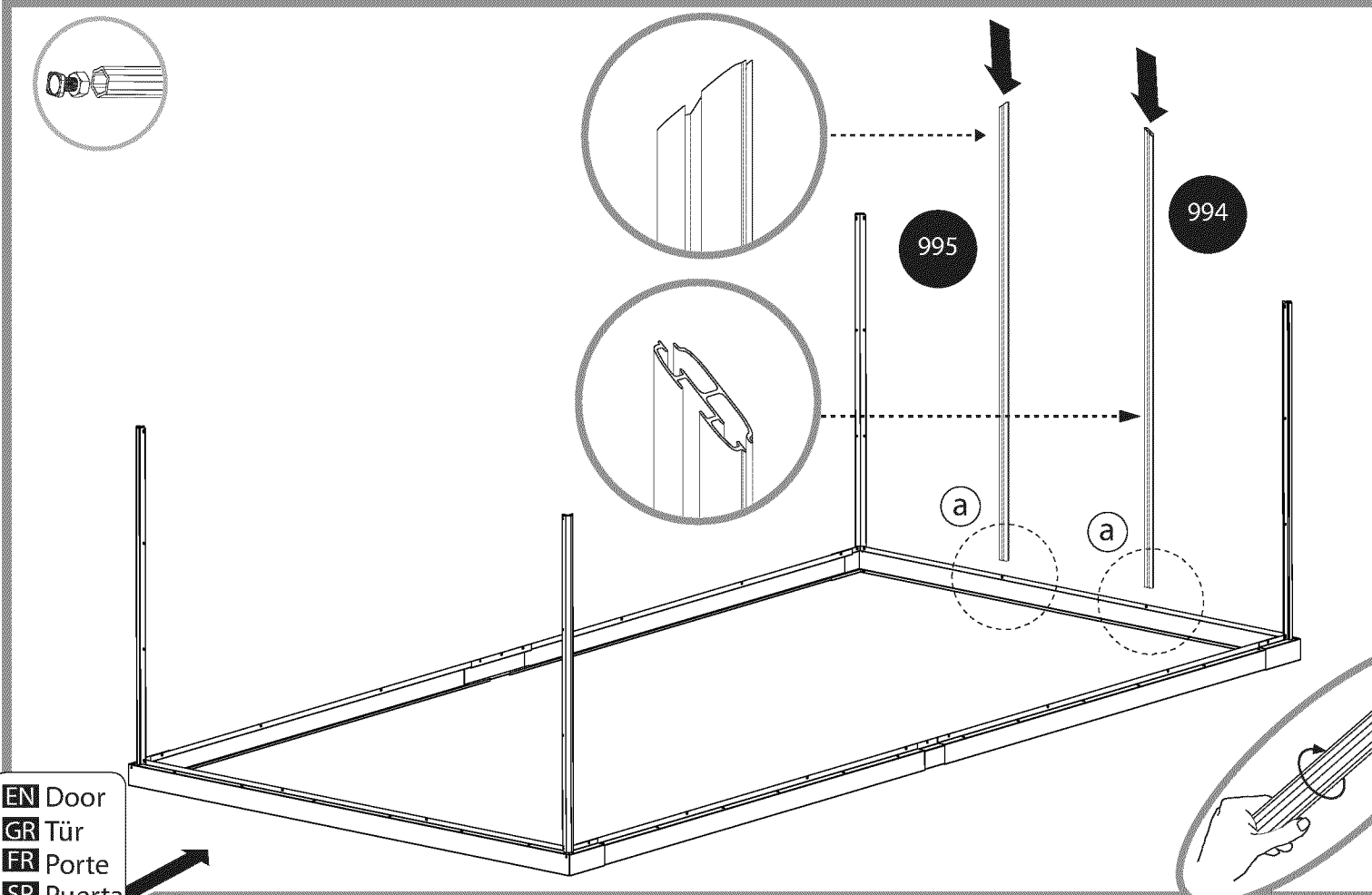
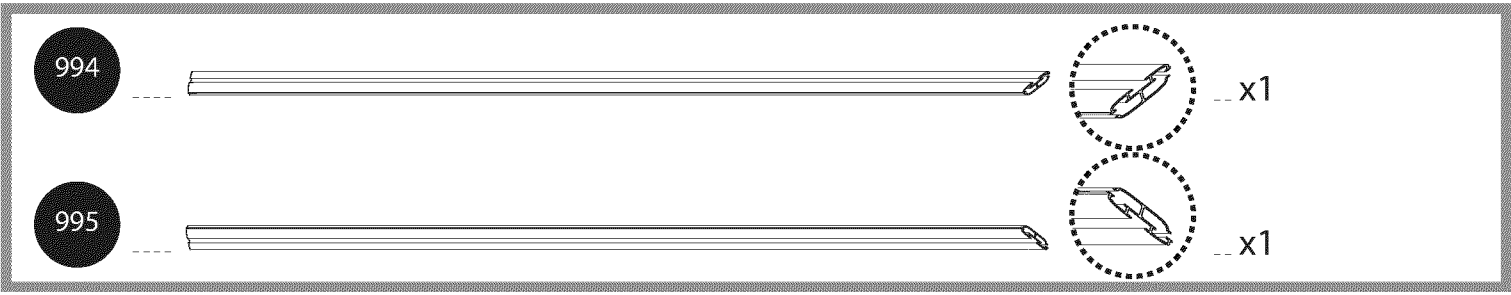
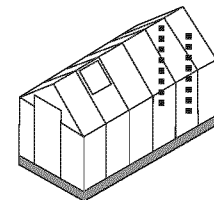

EN Door
 GR Tür
 FR Porte
 SP Puerta

6

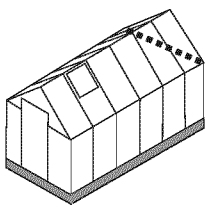

287



412







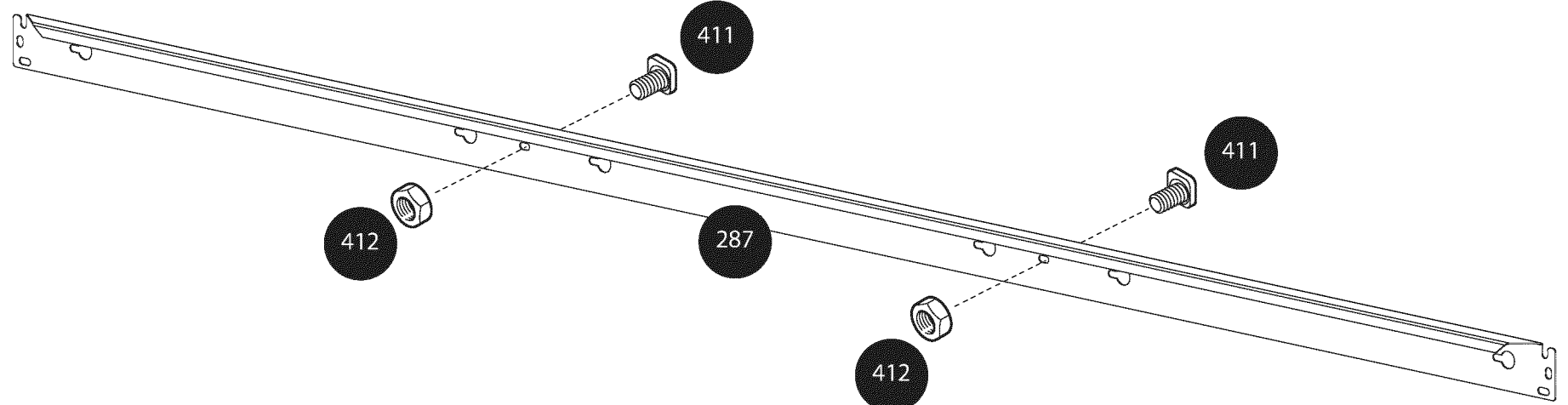

x2

411



x2



7      412  411

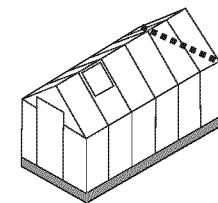

287



x1

411



x2

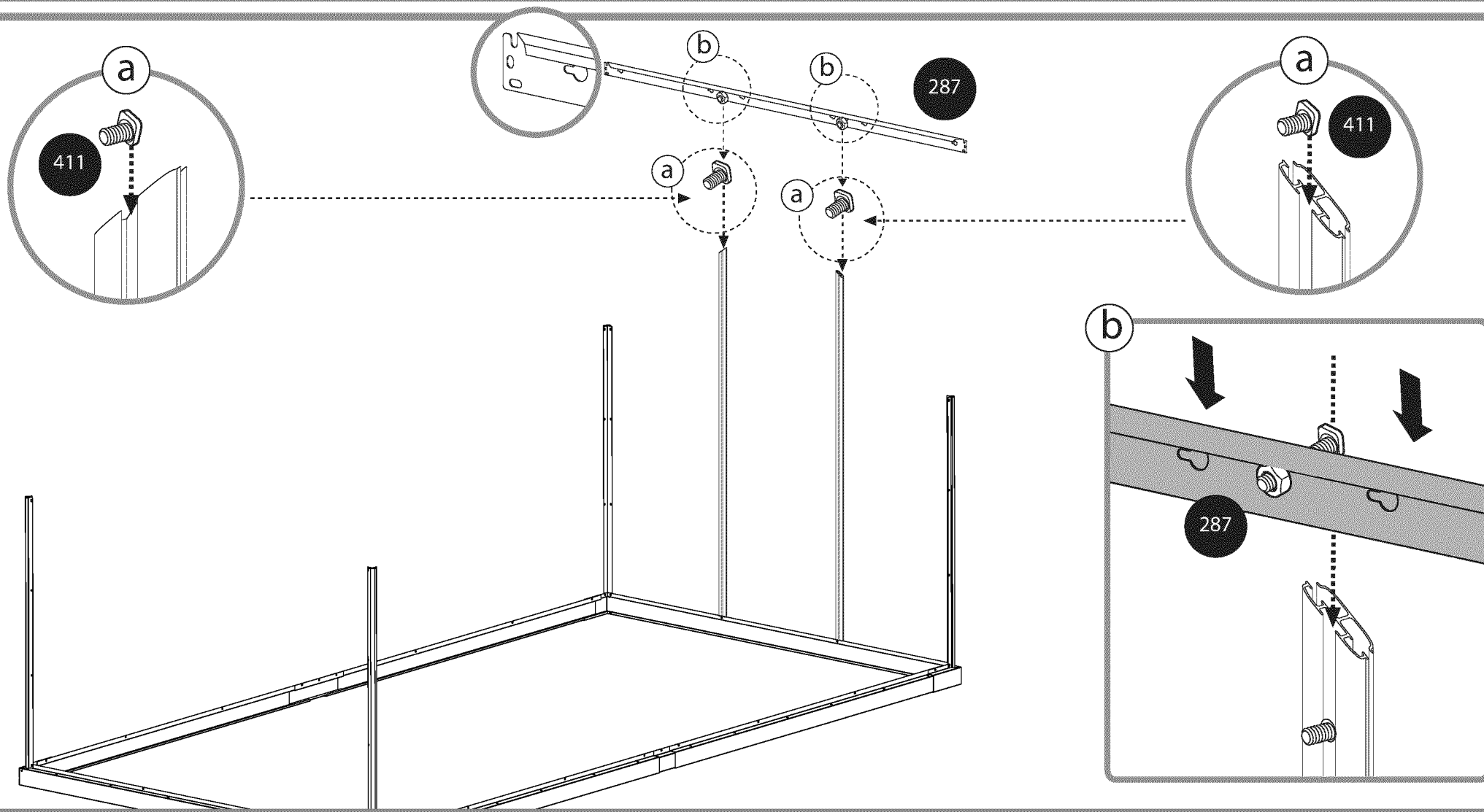

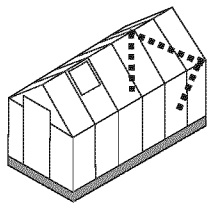

256

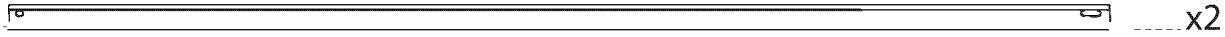

412



x4

411



x2

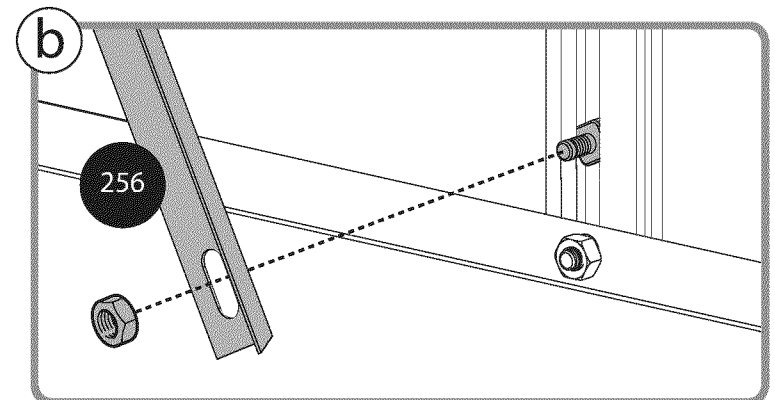
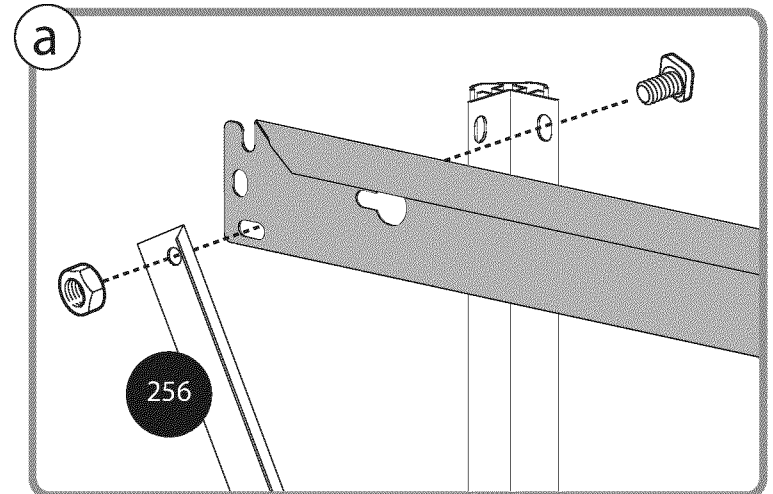
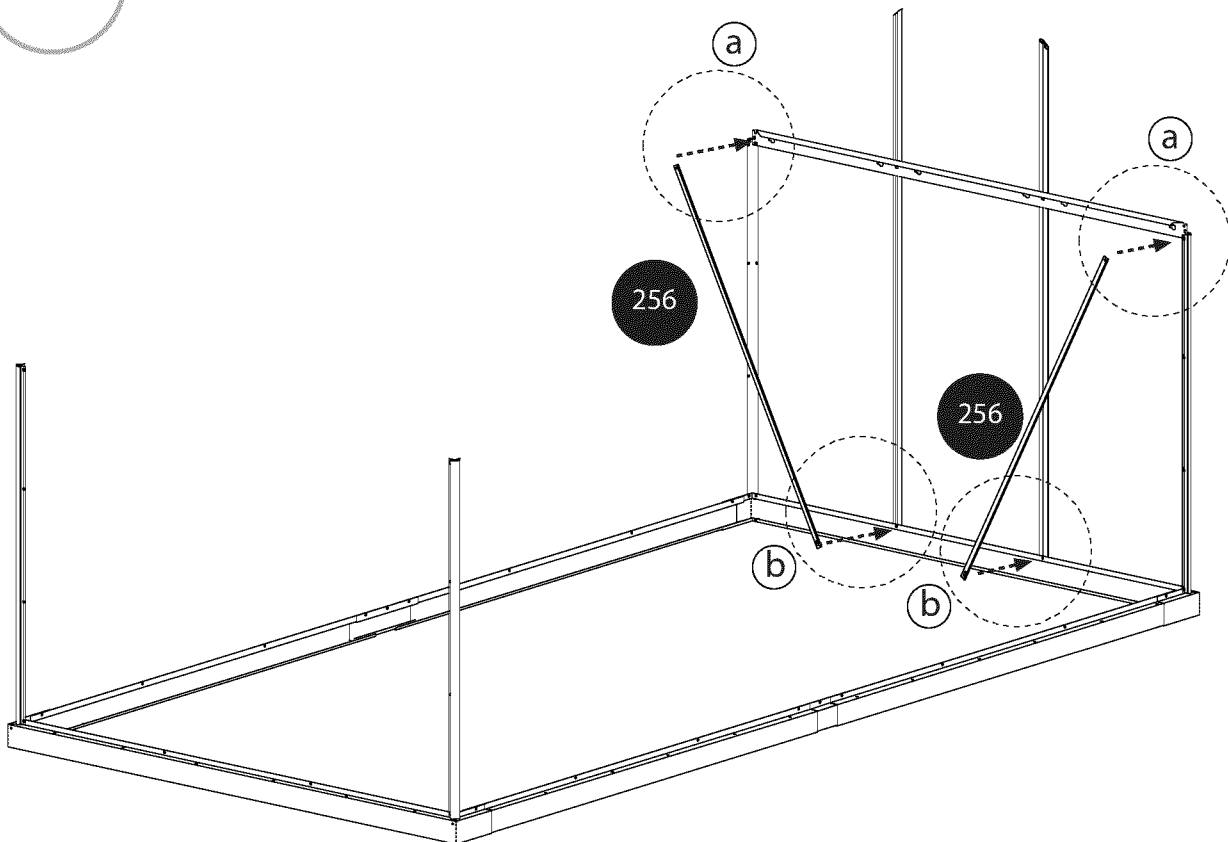
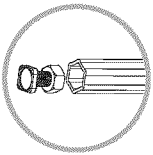

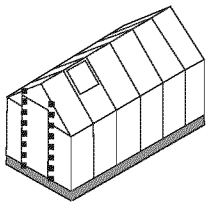

988

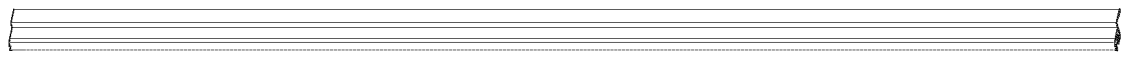

x1

987

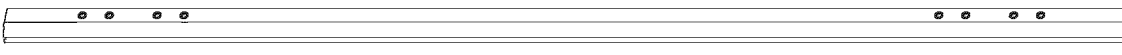

x1

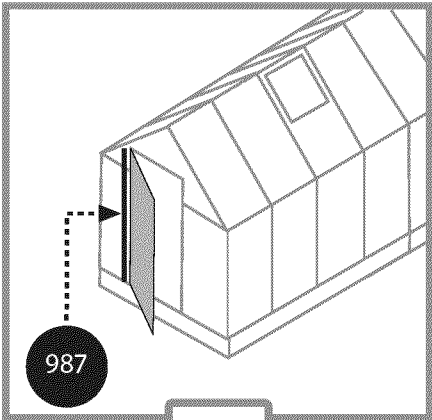

987

or

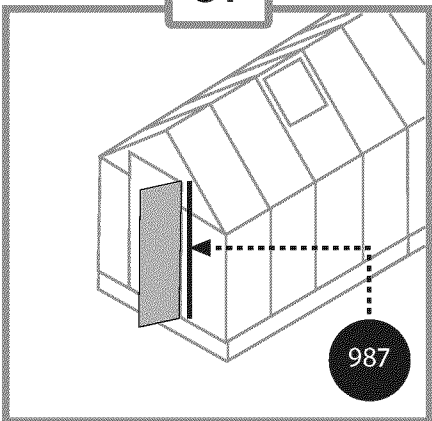

987

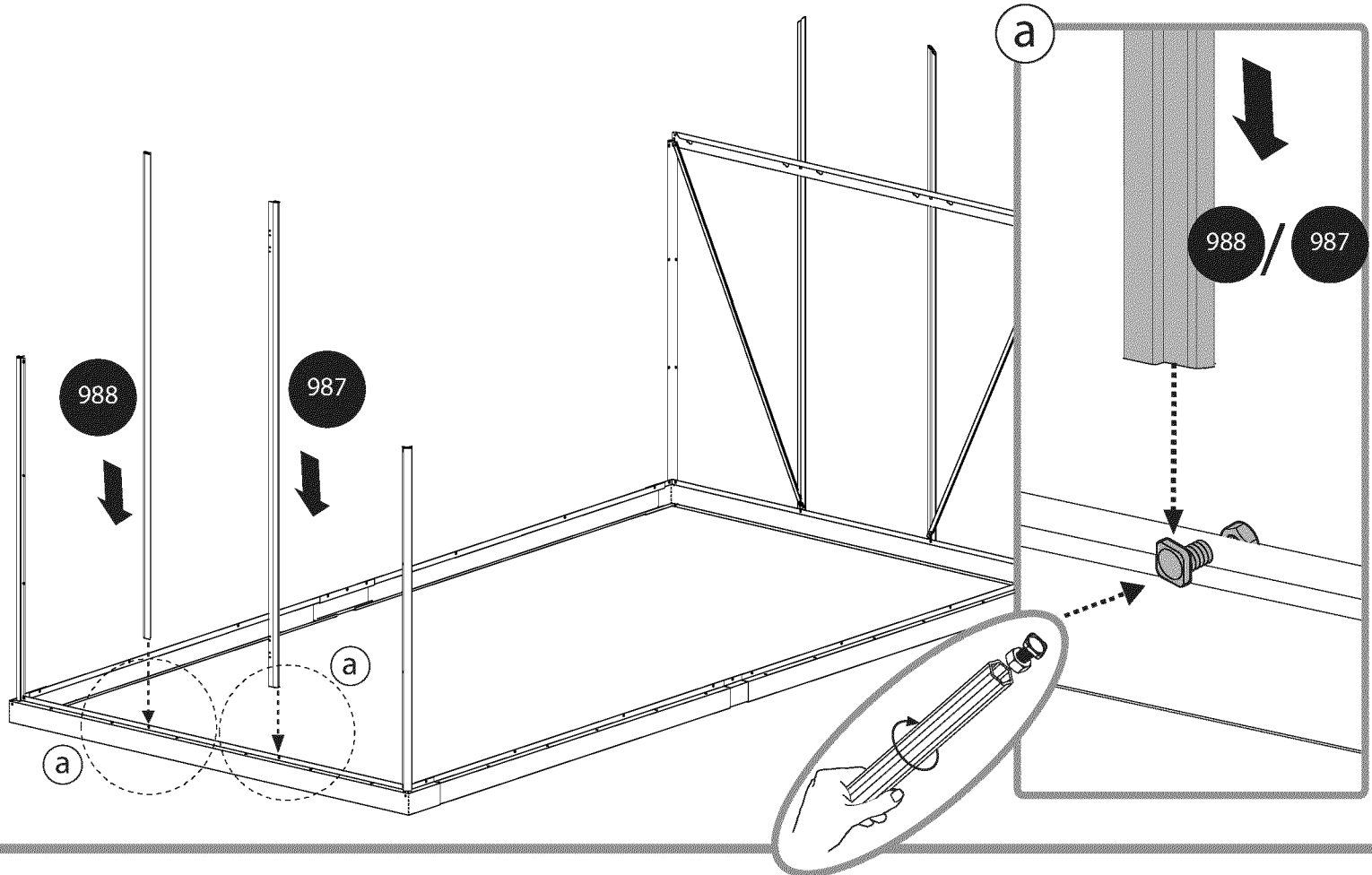

a

988

987

988

987

a

a

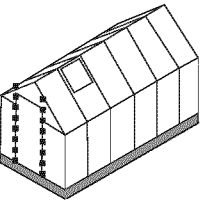

411  x2

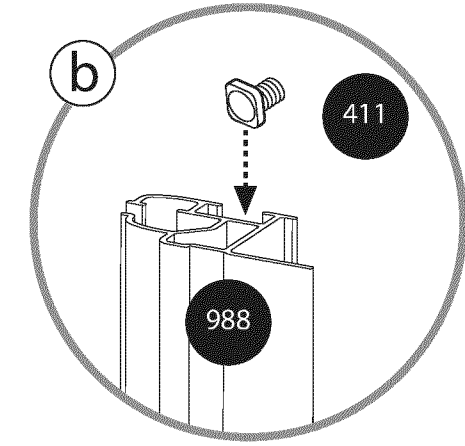
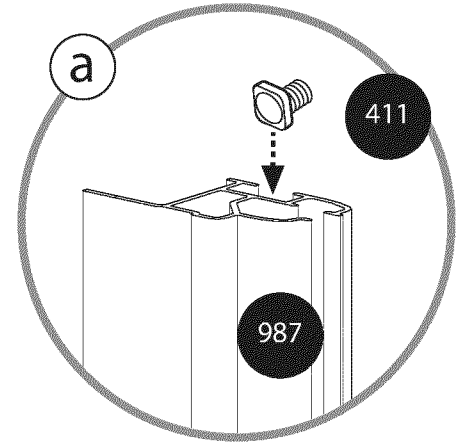
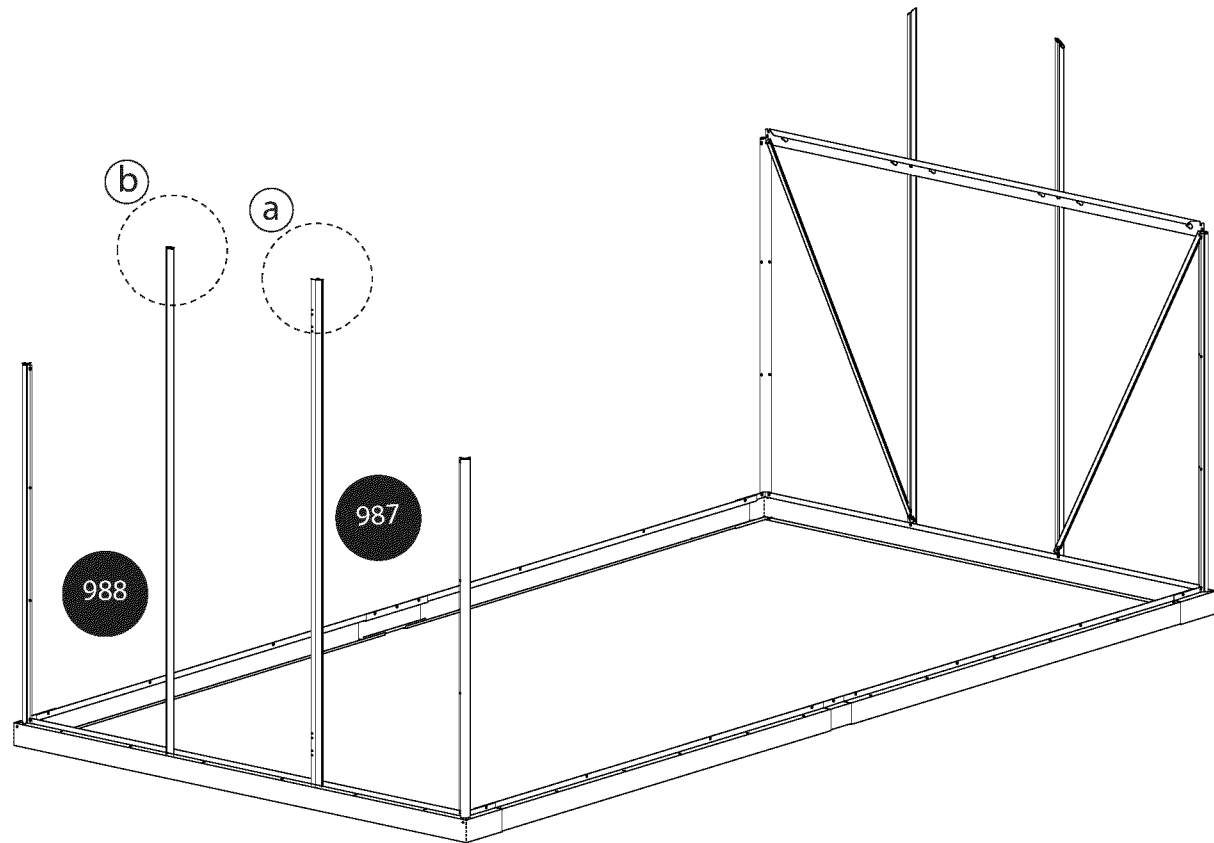

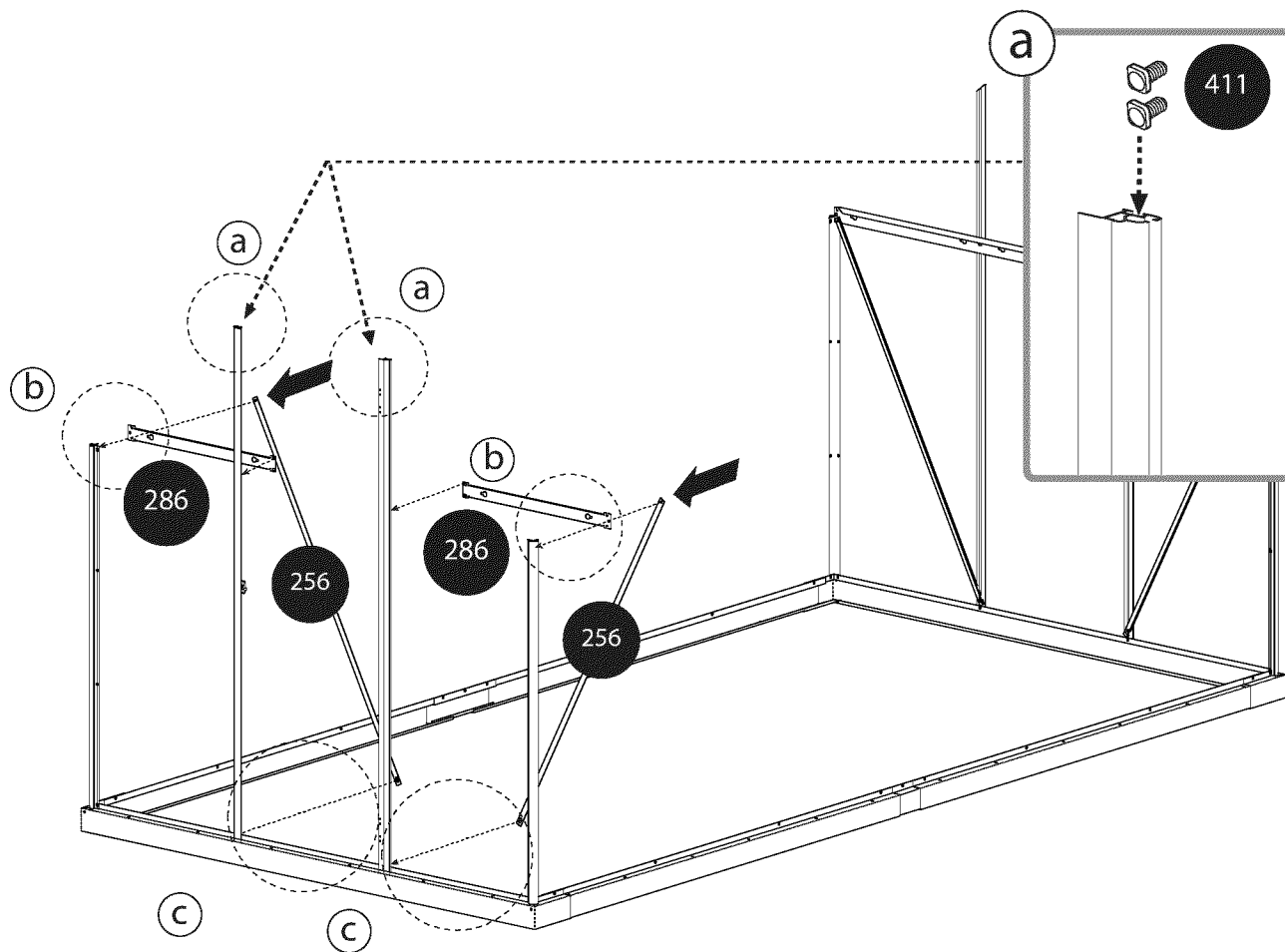
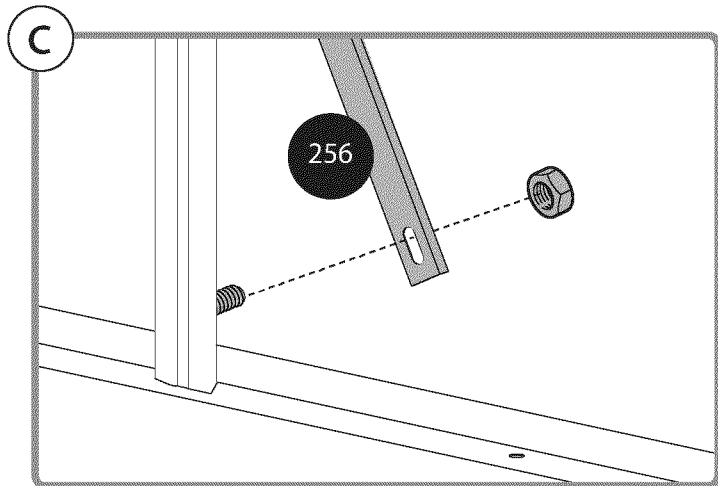
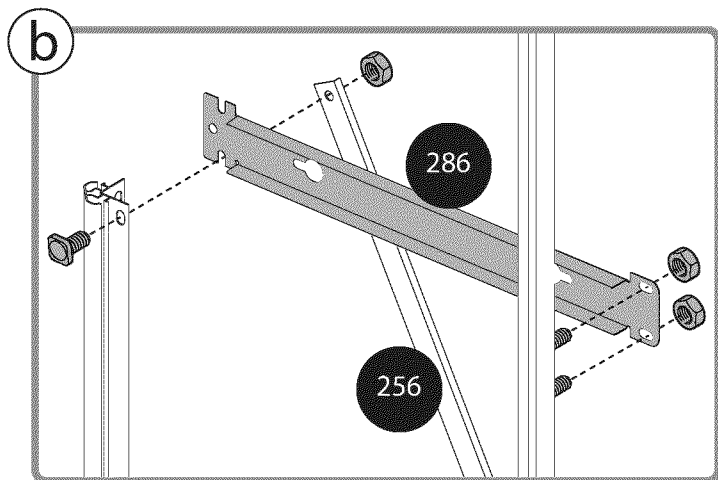
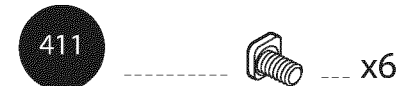
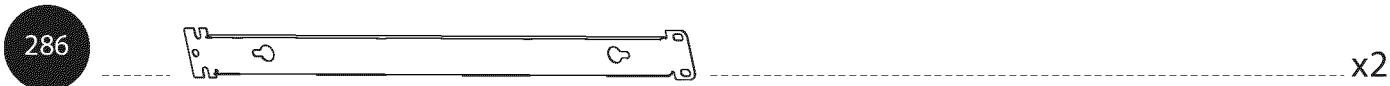
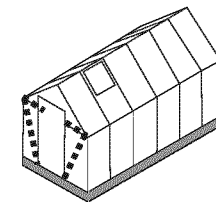

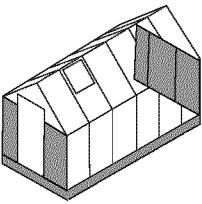

7011

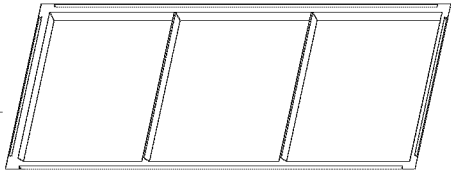

x5

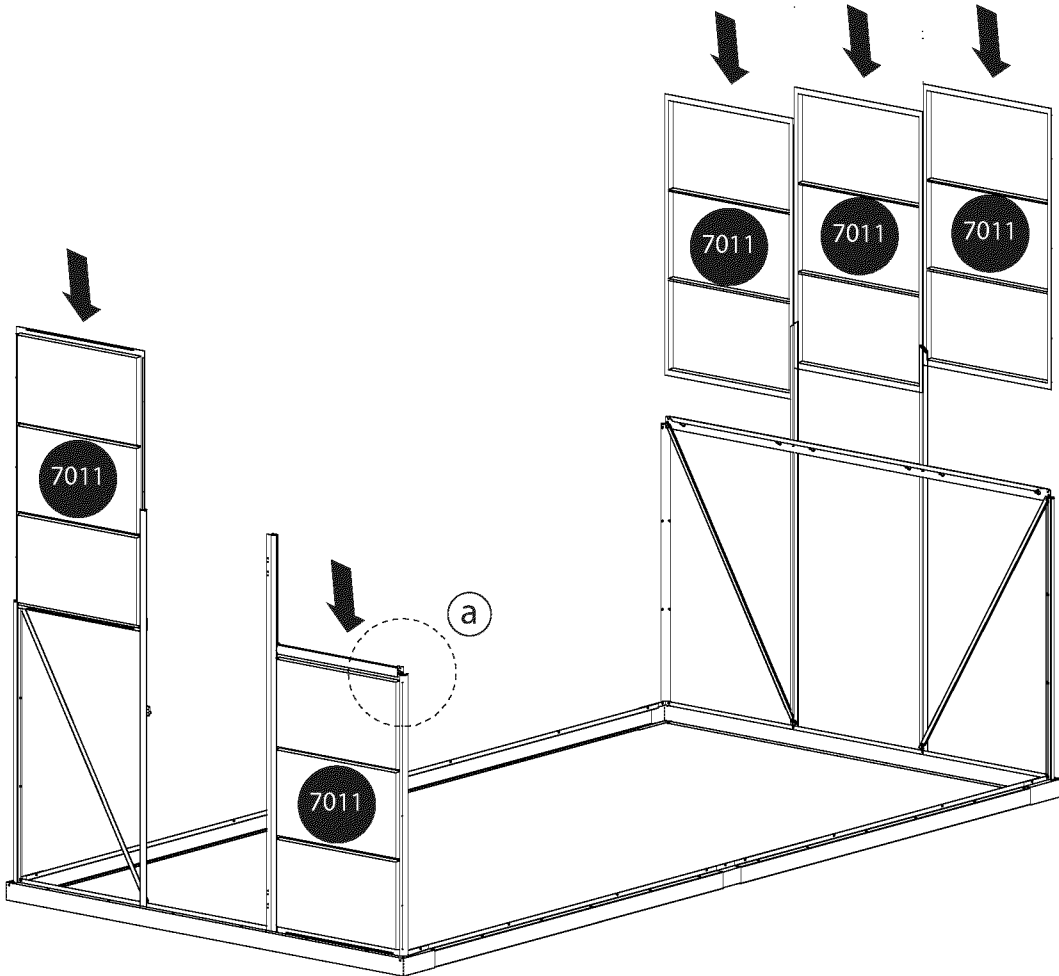

a

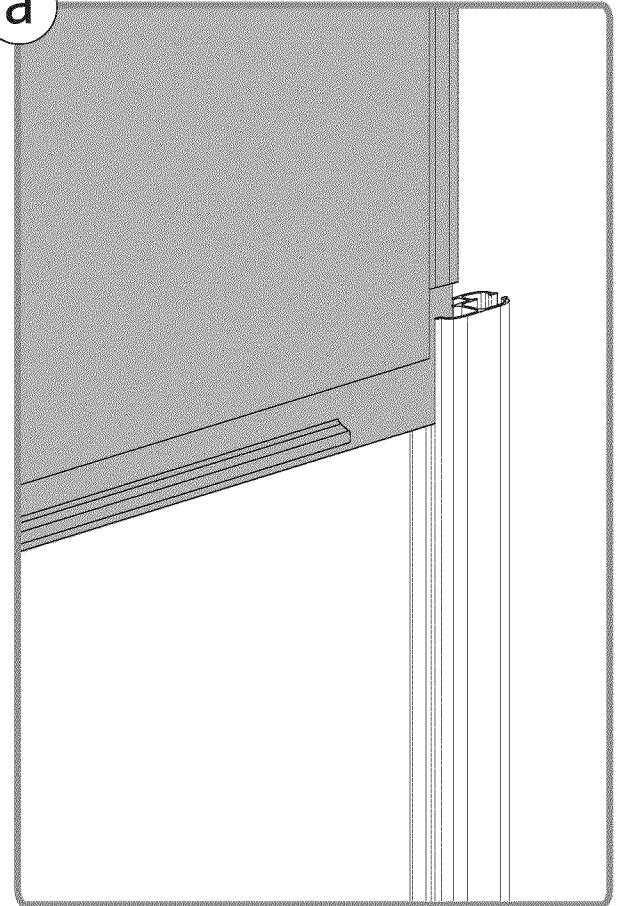

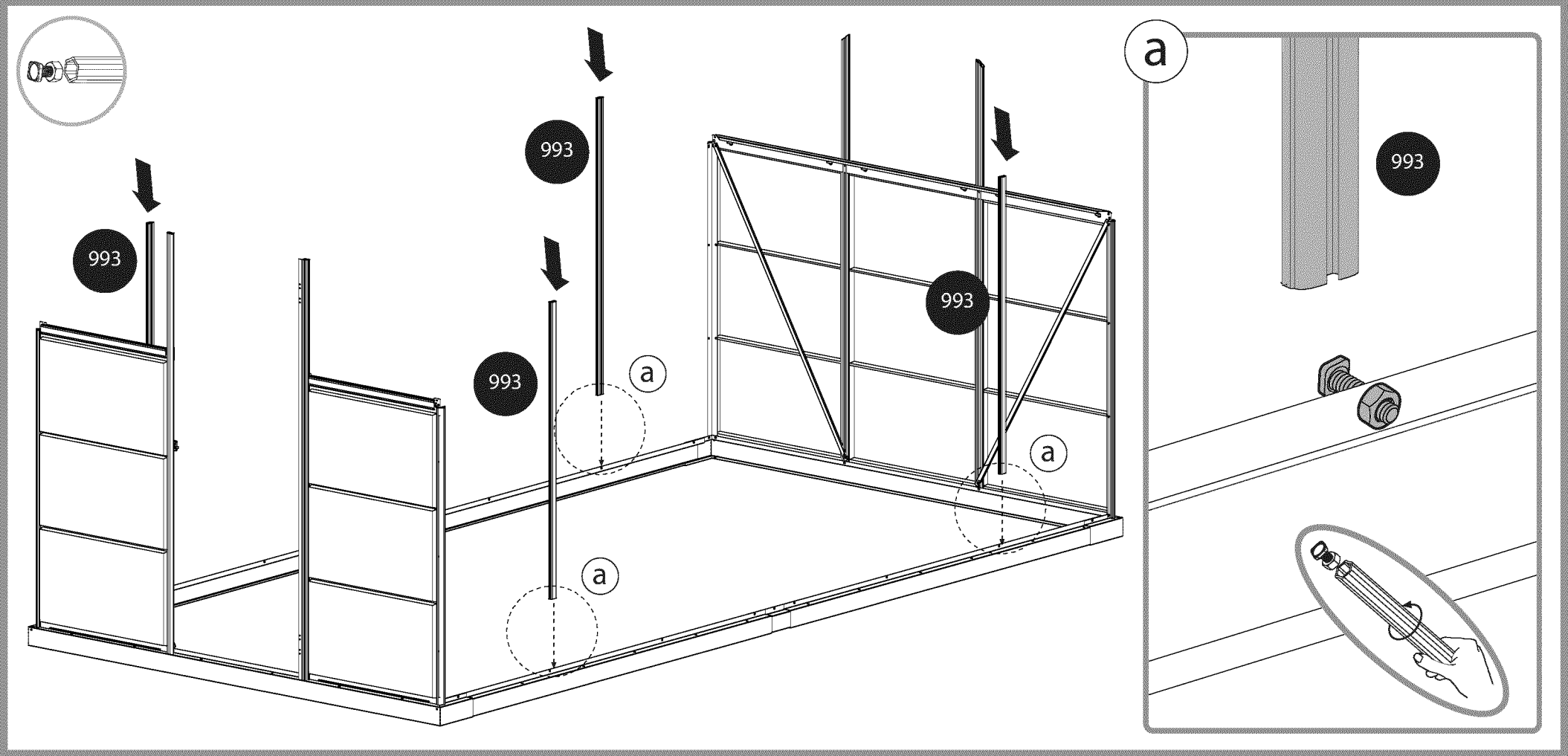
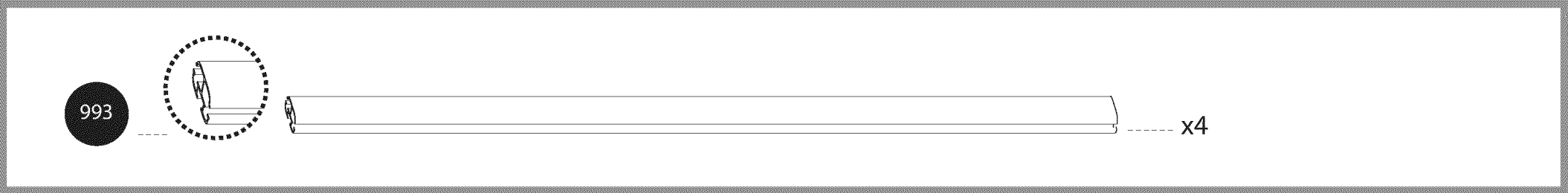
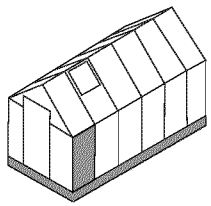

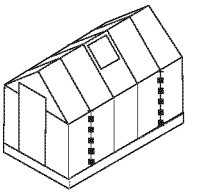

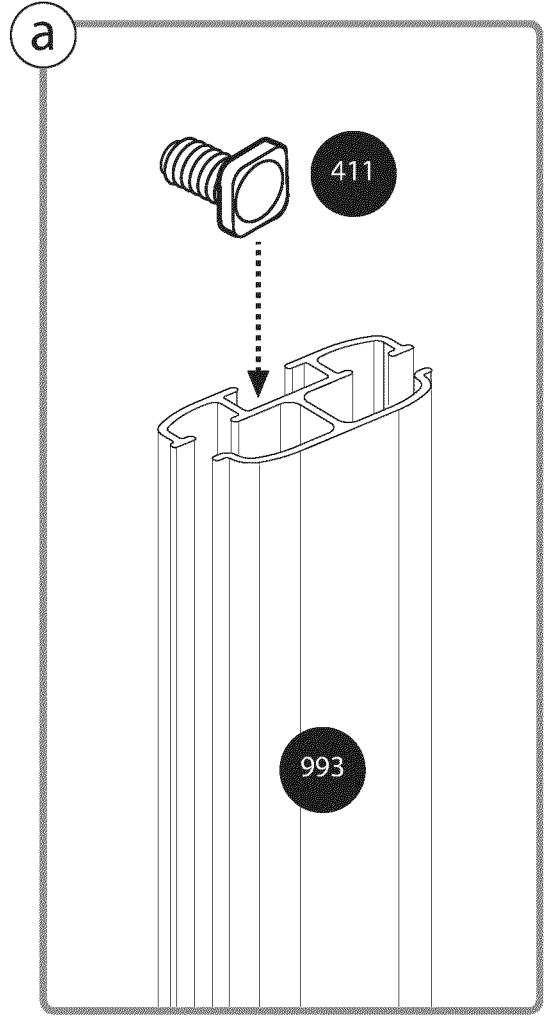
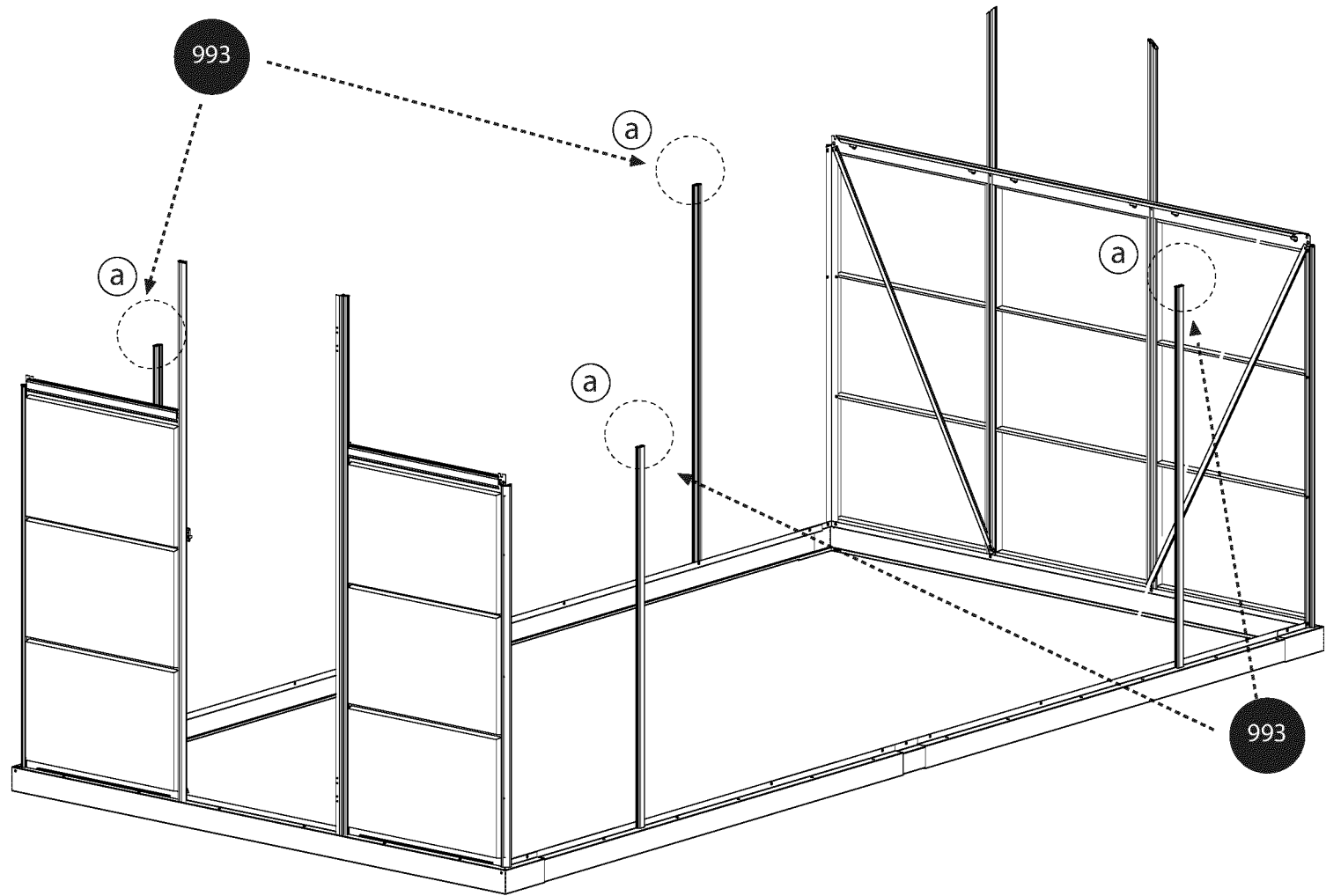

411

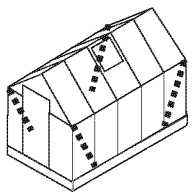



411  x4

256  x4

412  x8

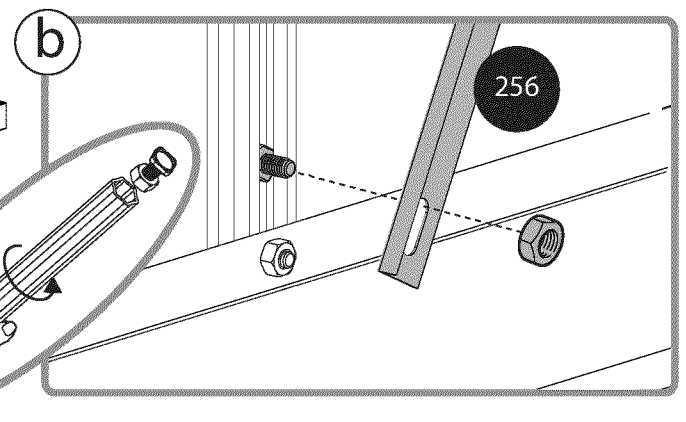
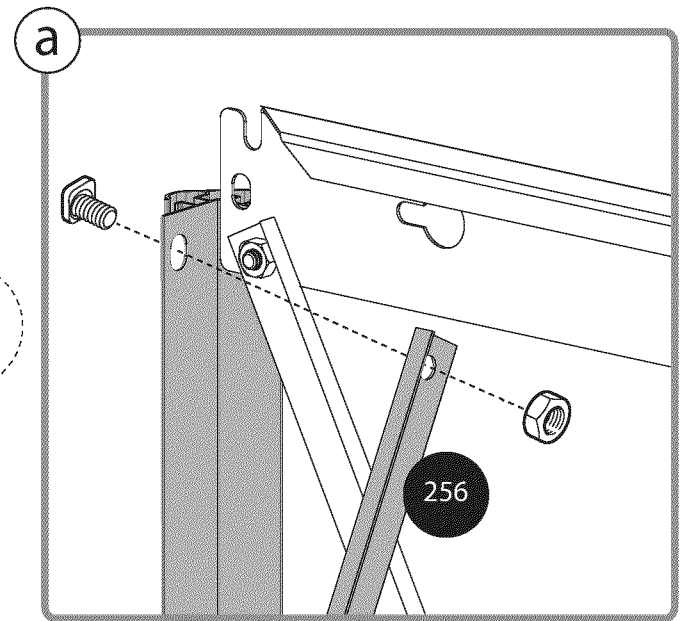
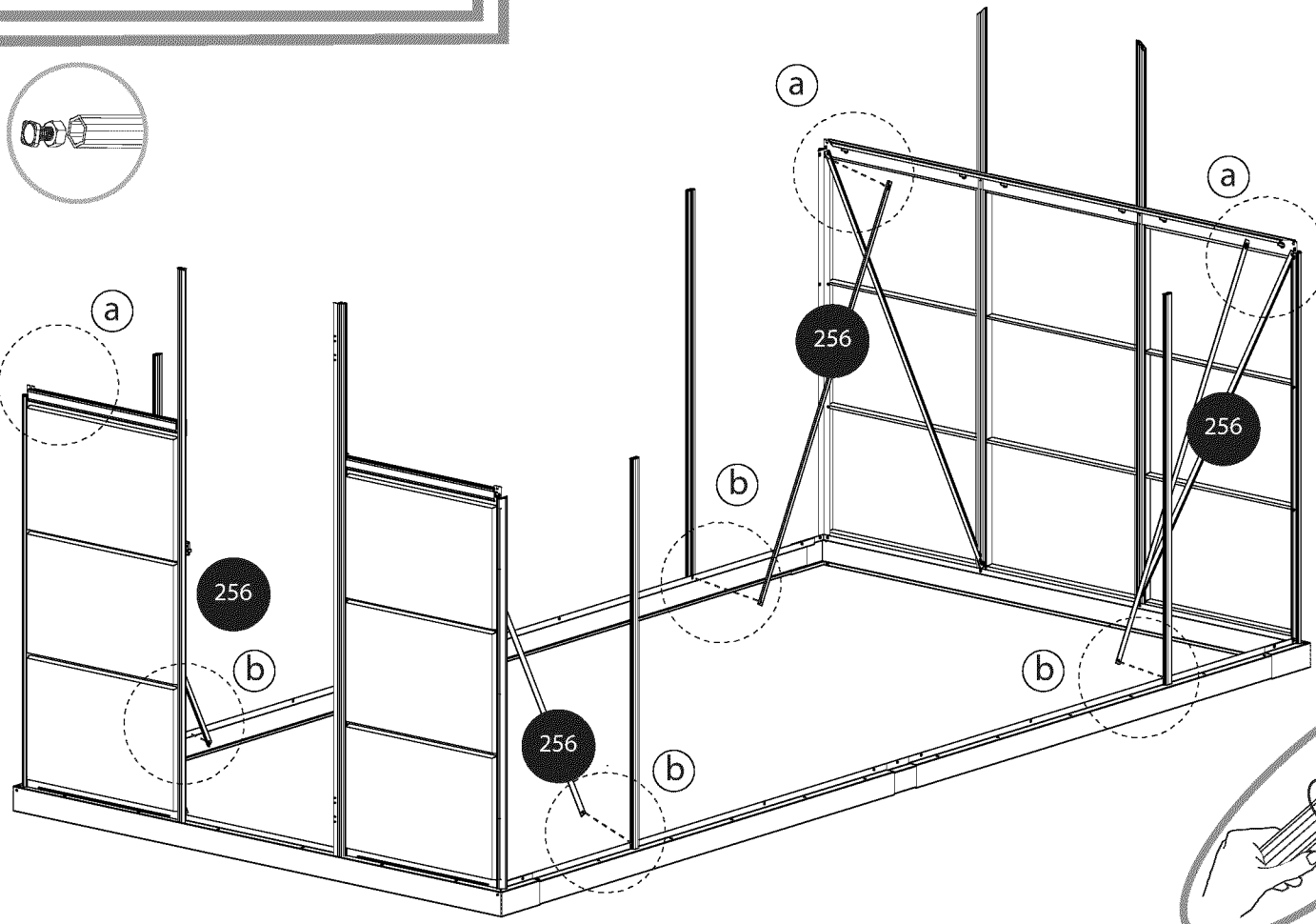
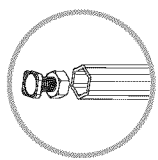

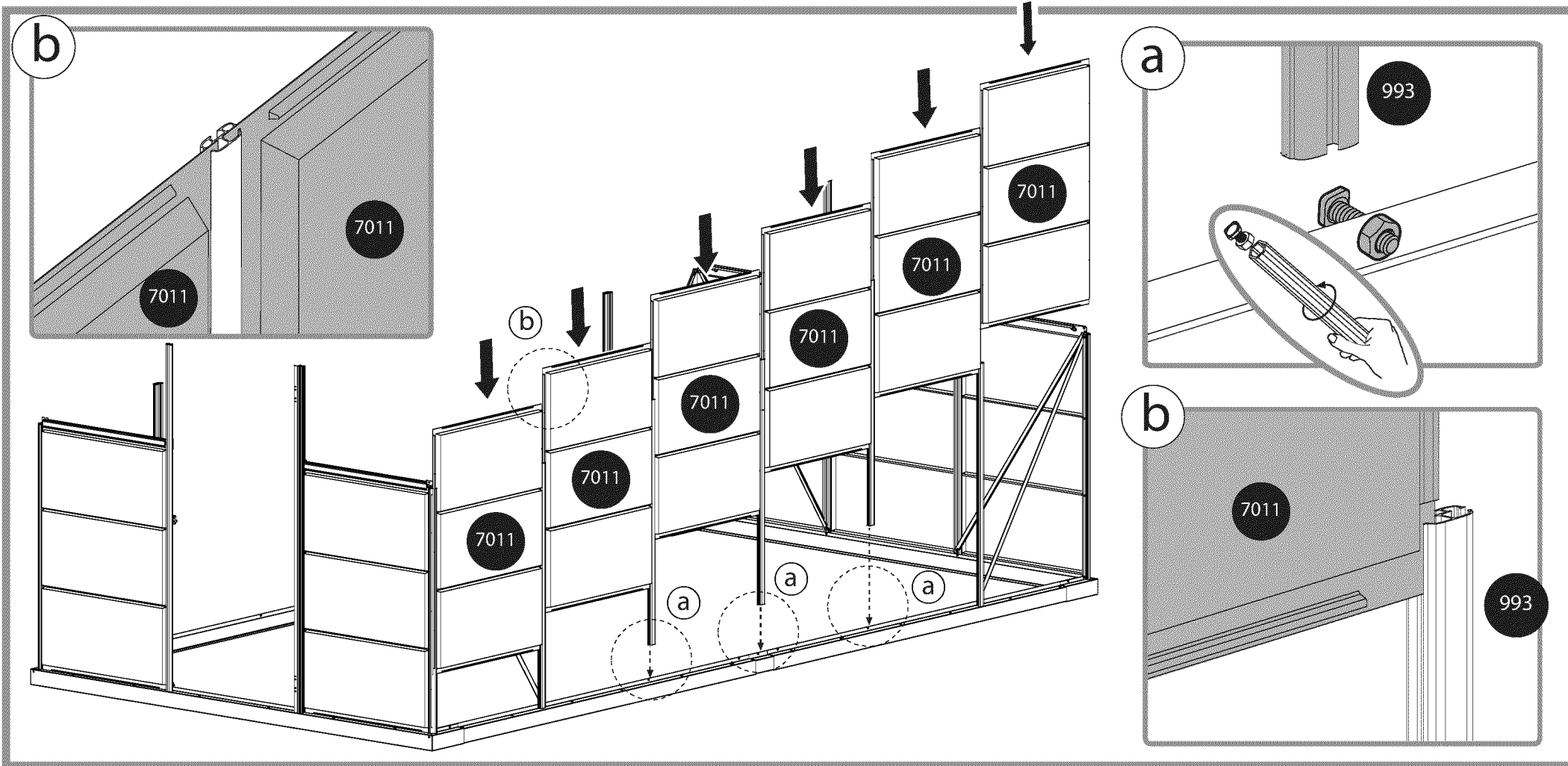
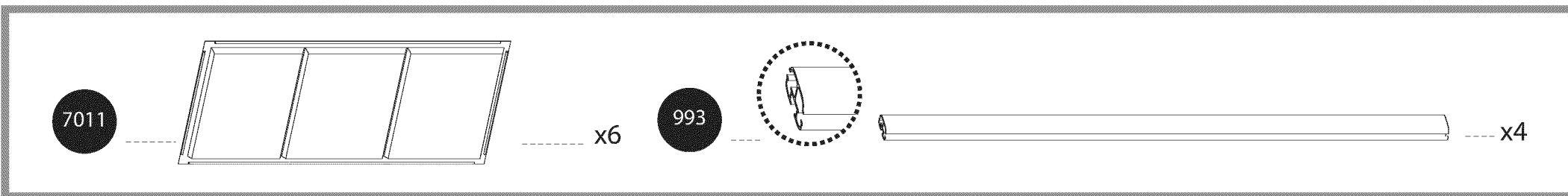
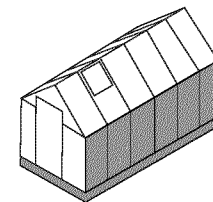

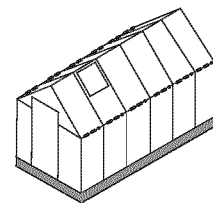

318
PVC

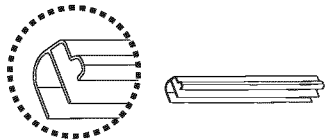

x6

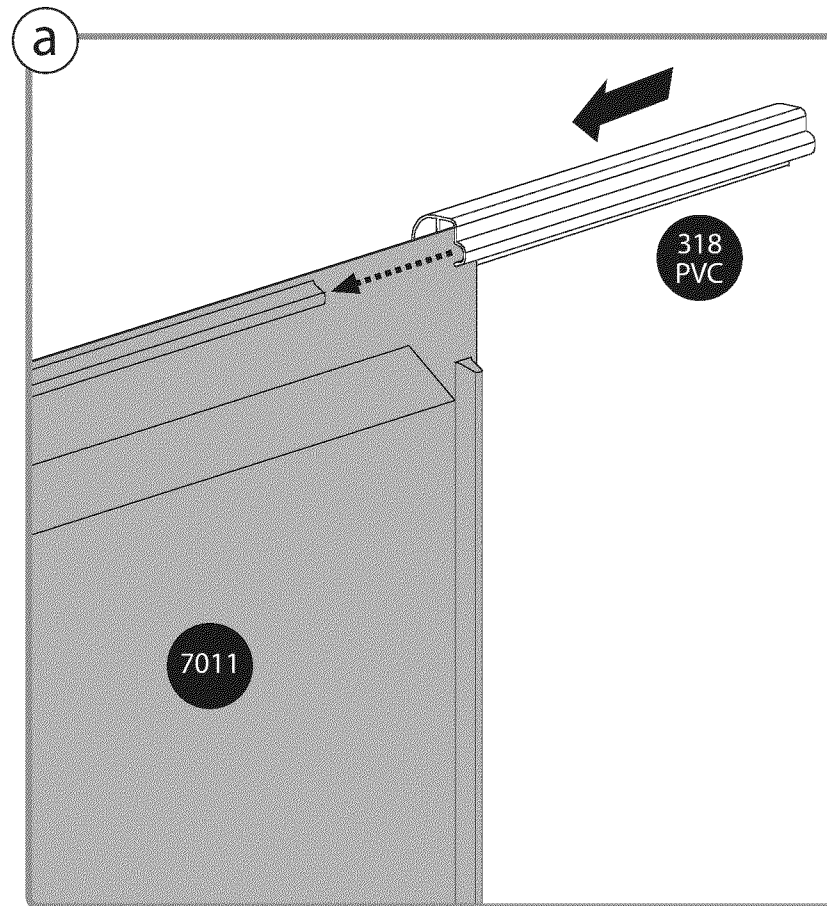
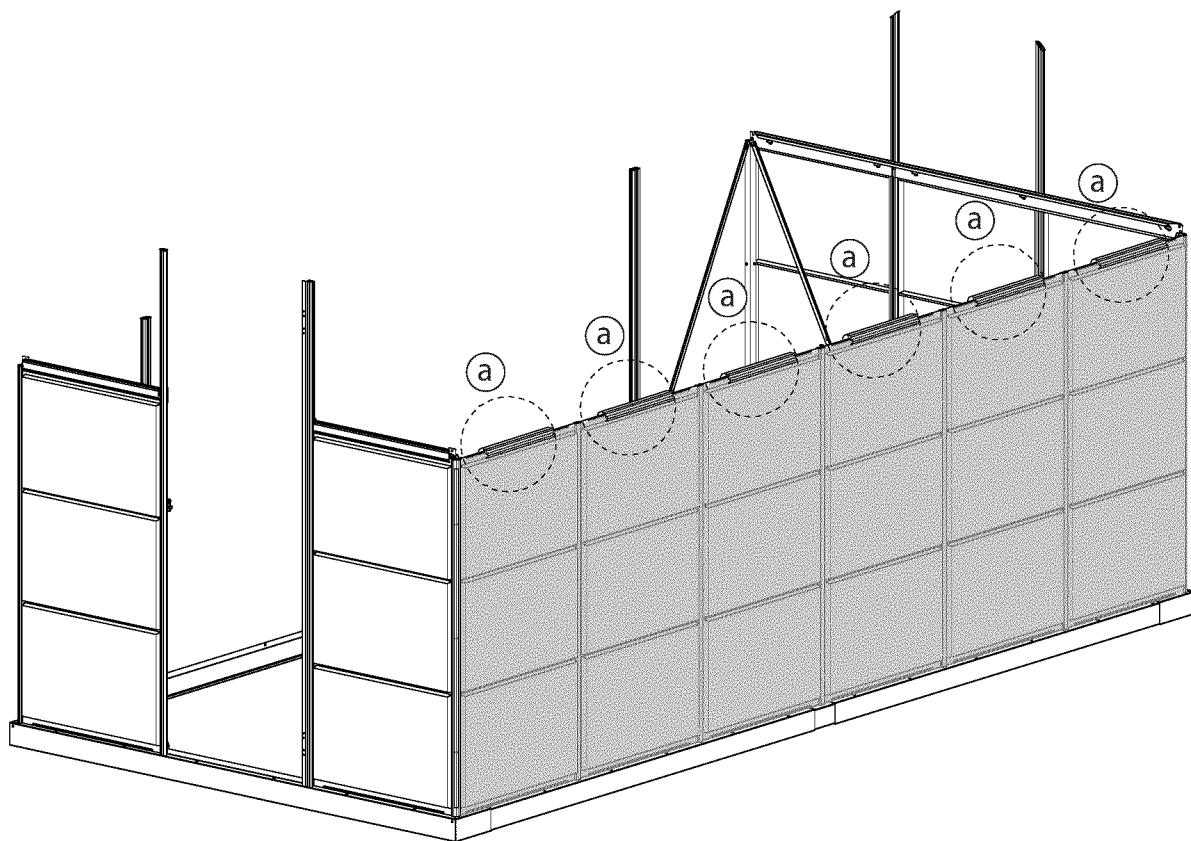



412  x5

411  x5

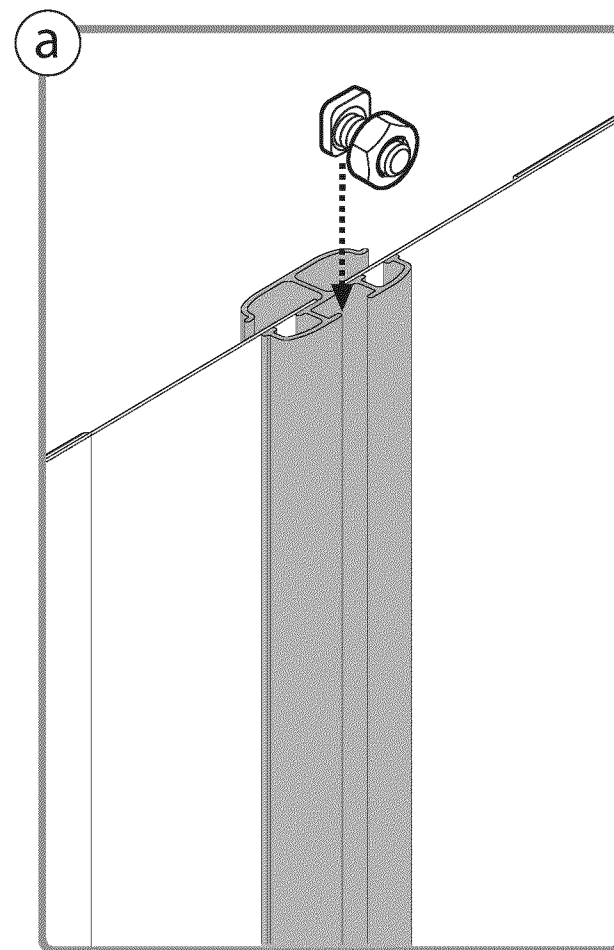
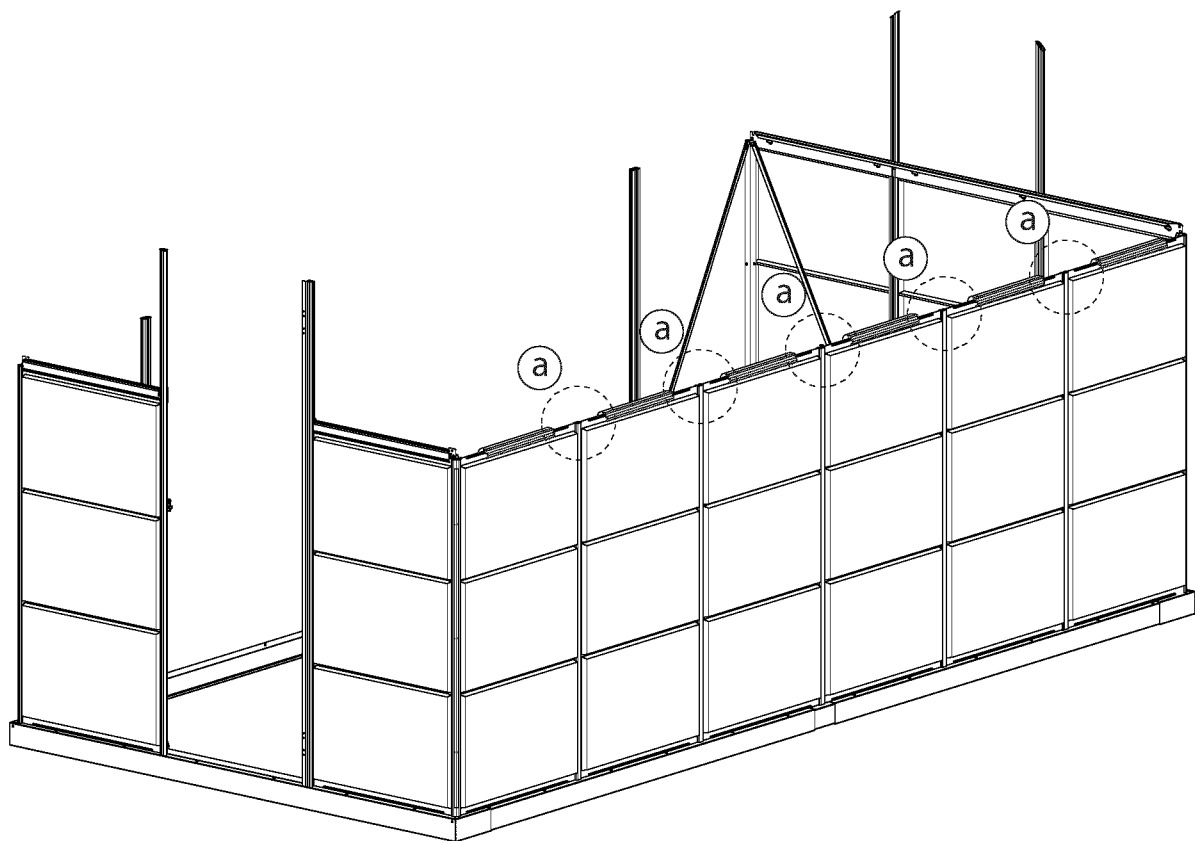

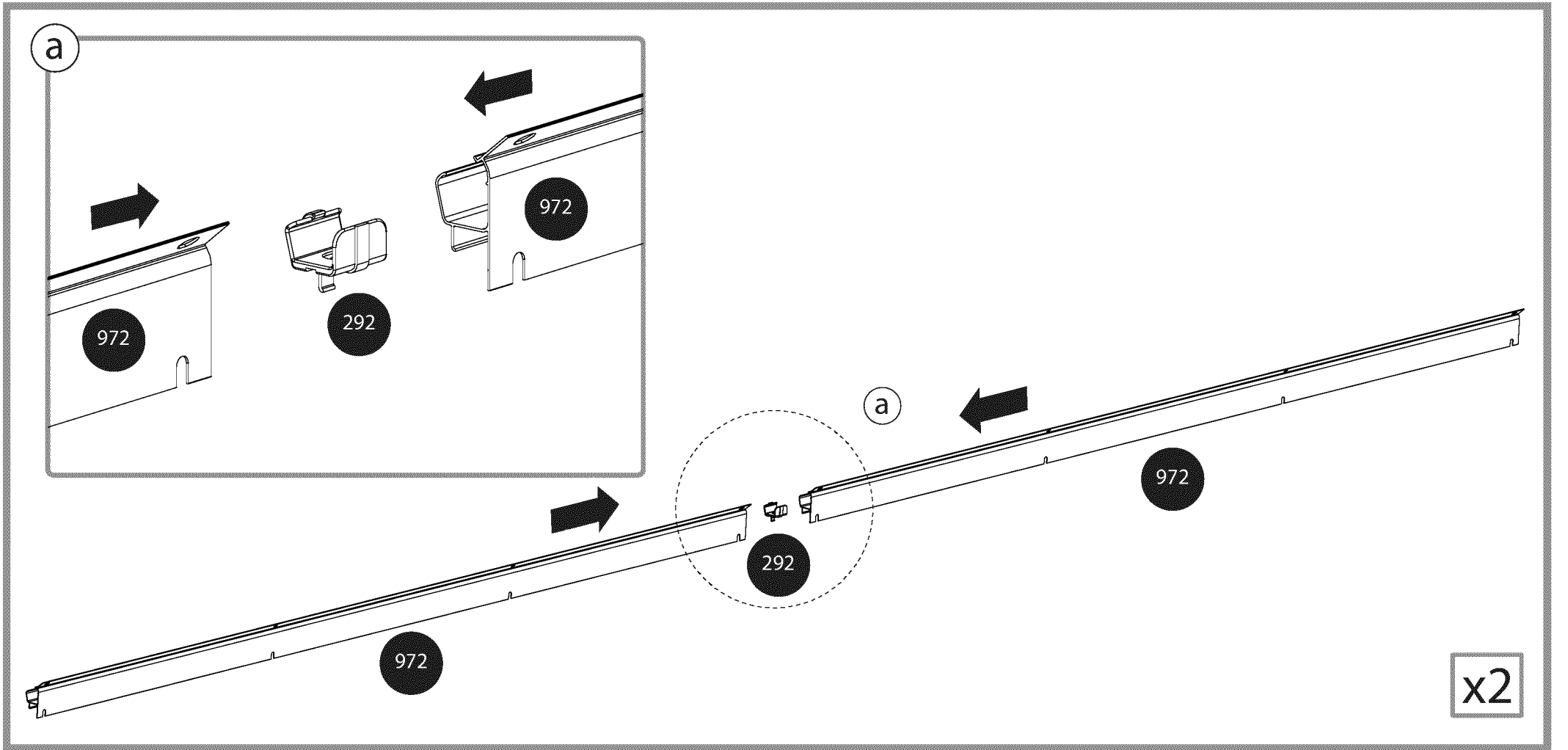
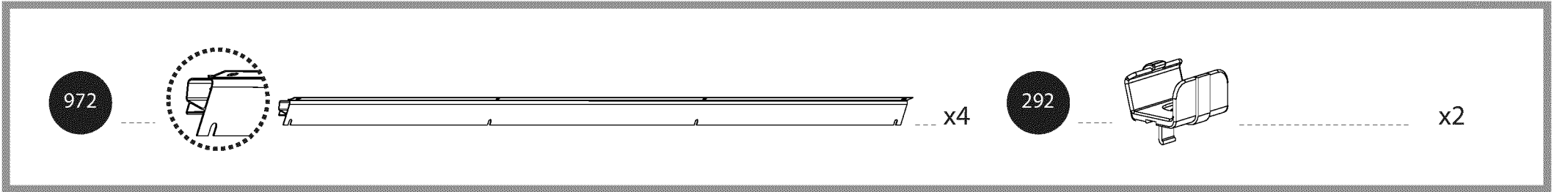
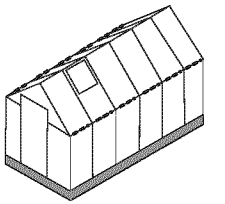

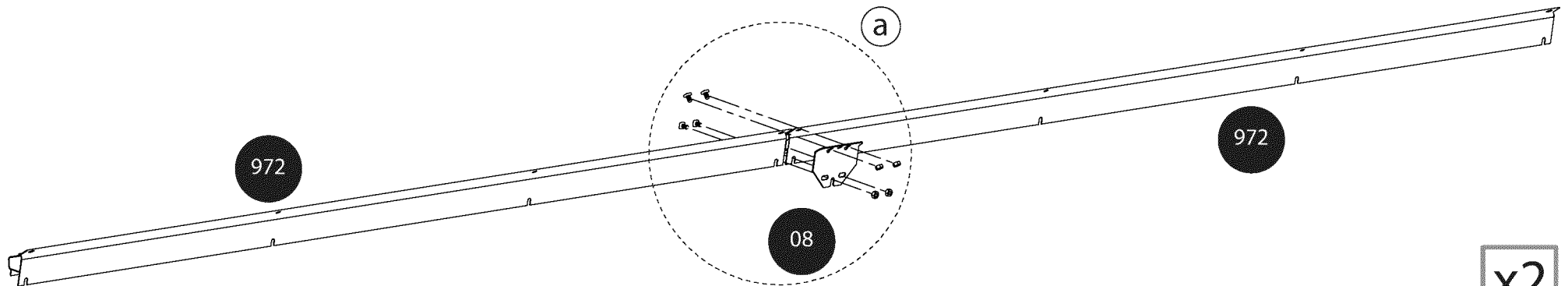
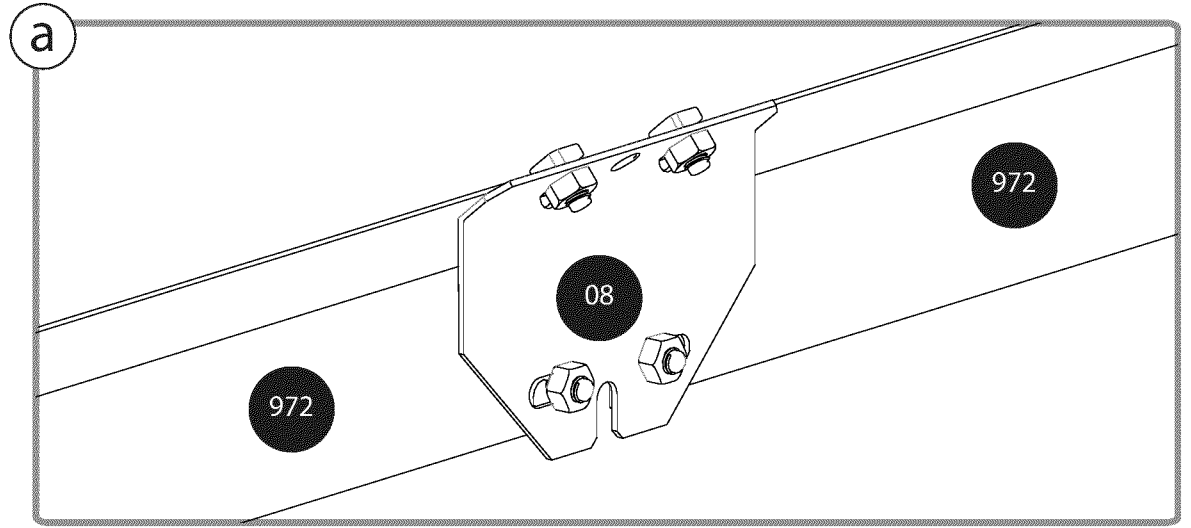
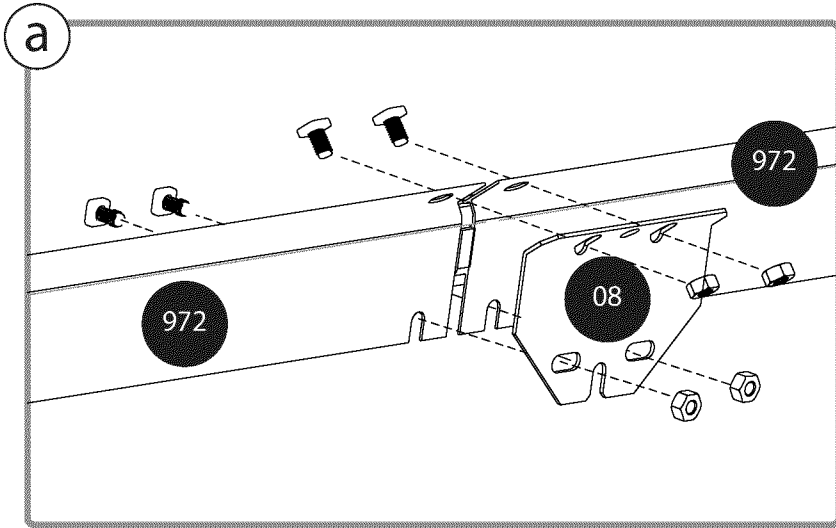
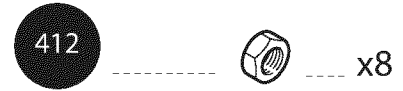
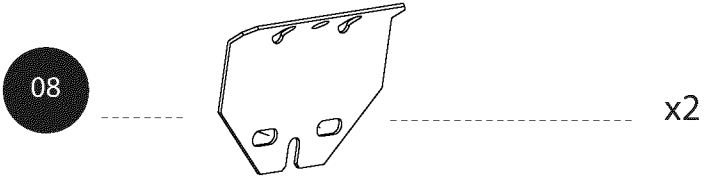
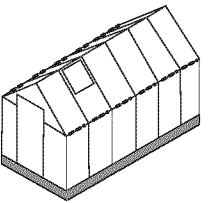

x2

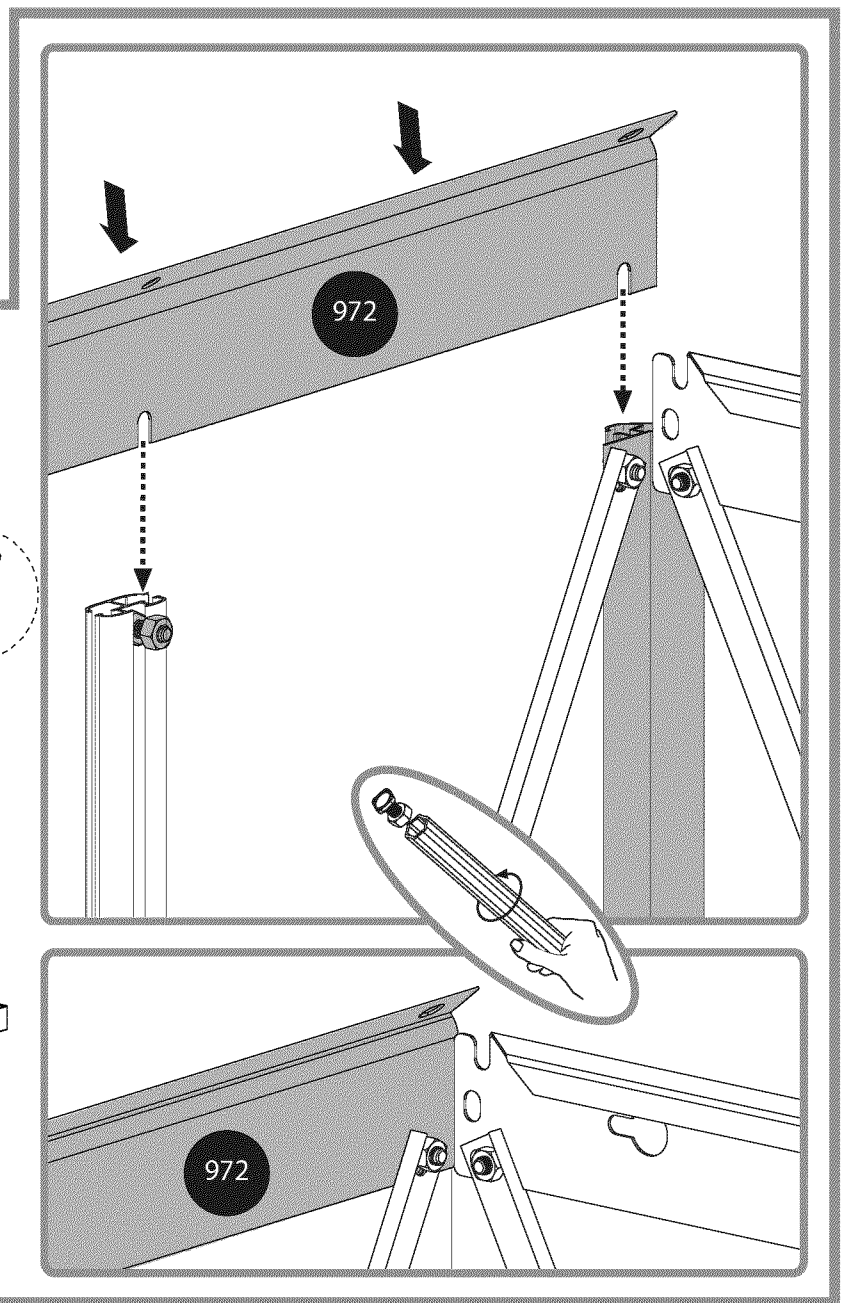
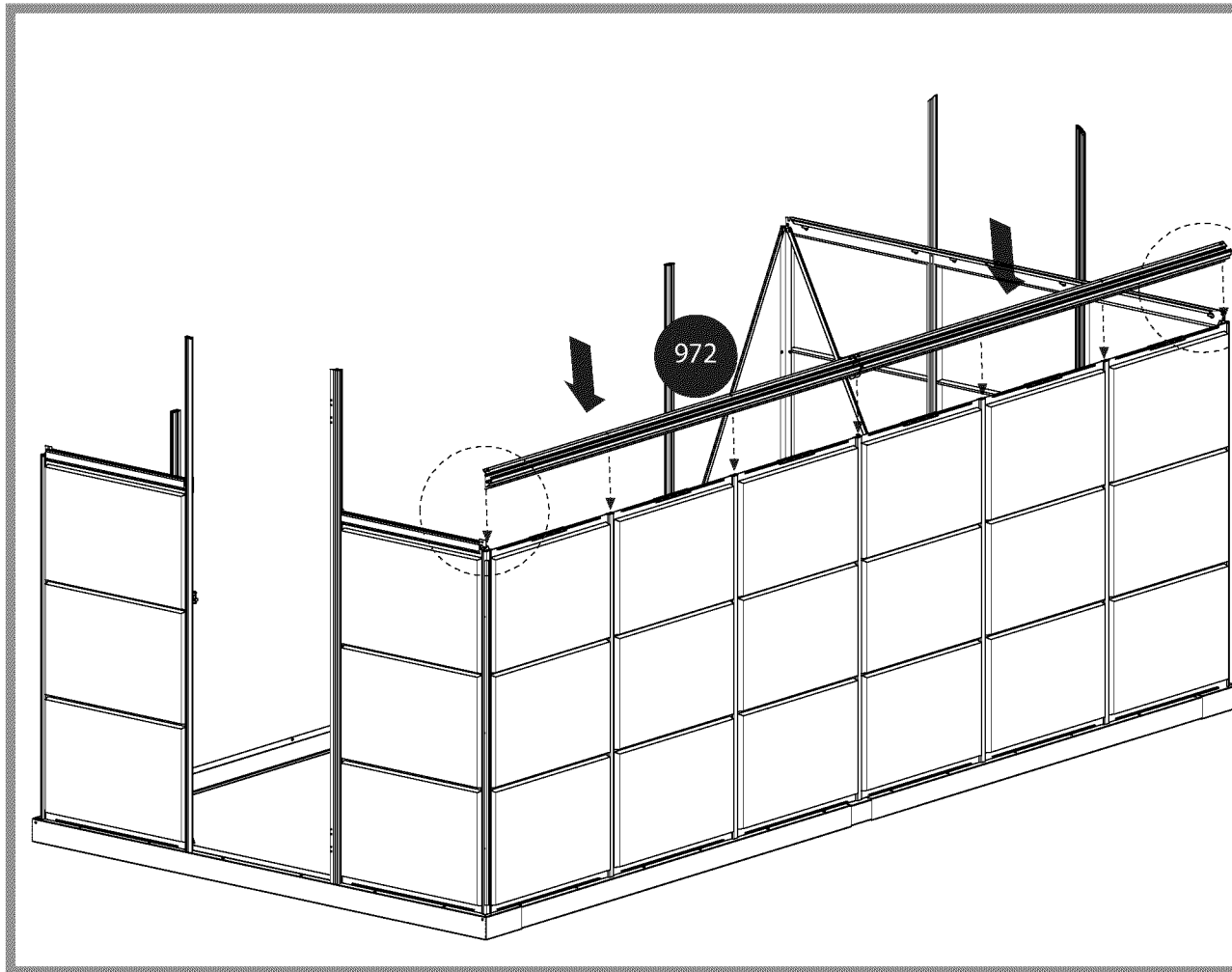
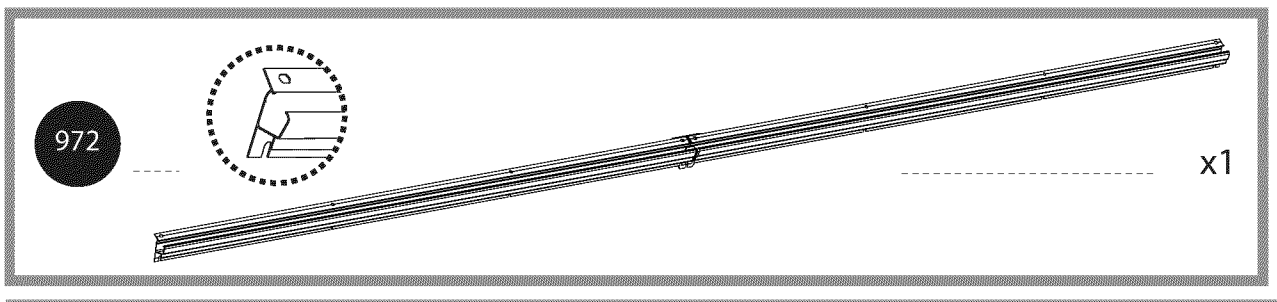
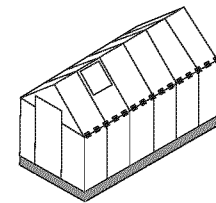

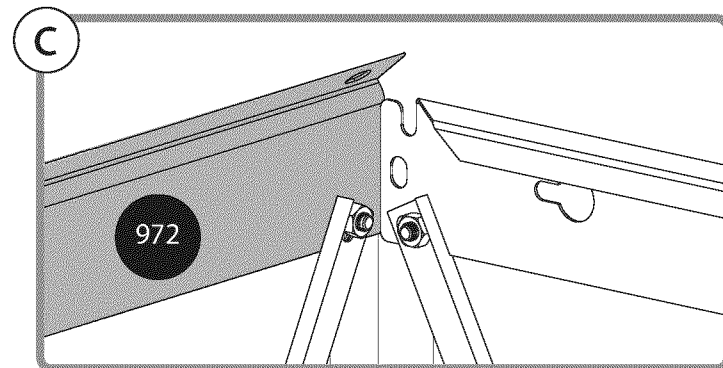
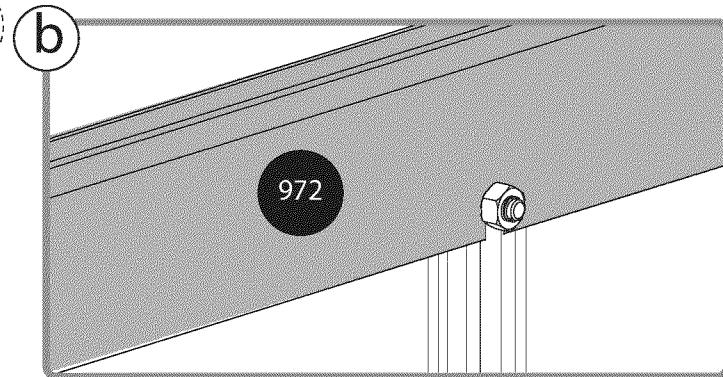
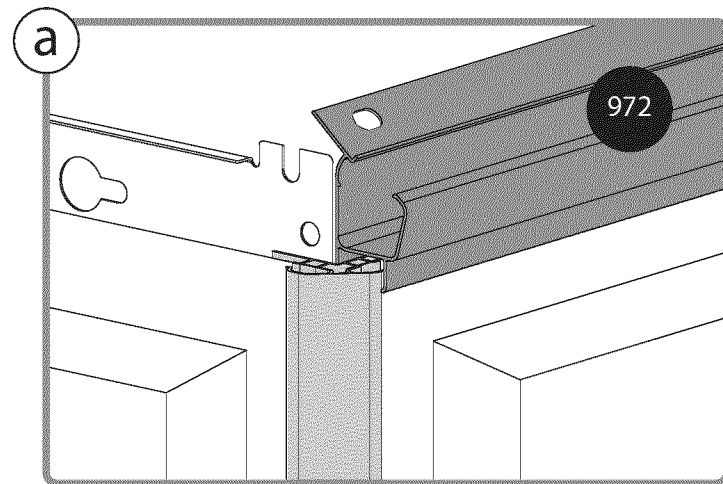
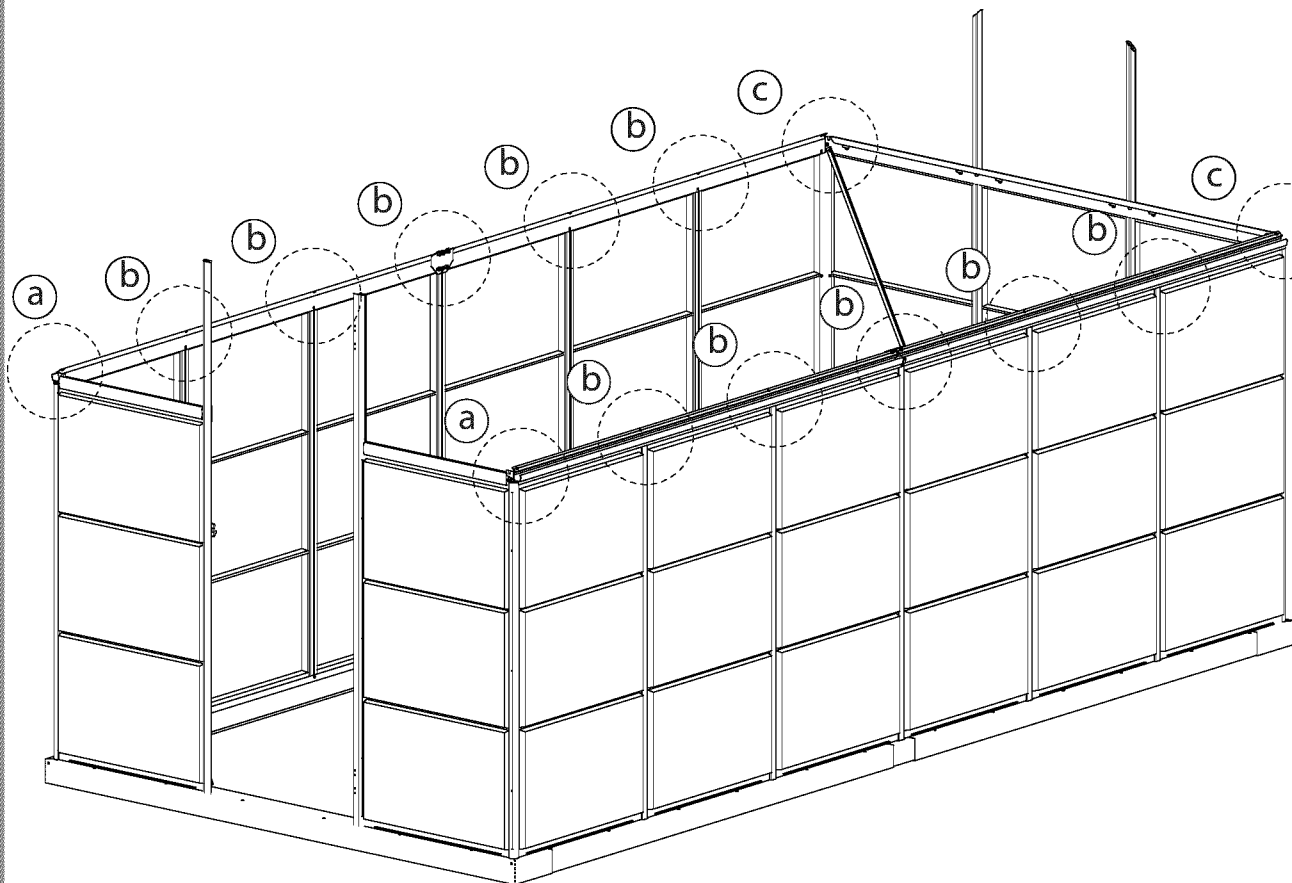
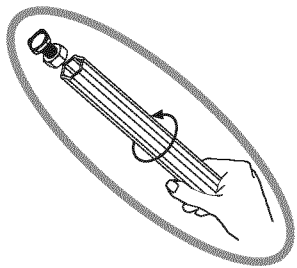
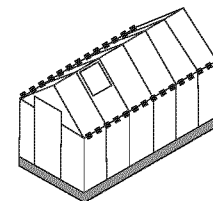

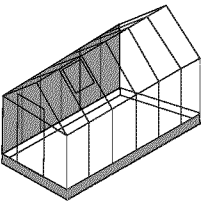

7011

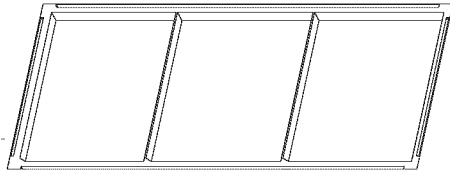

x6

993

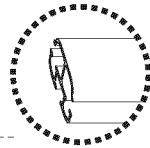

x3

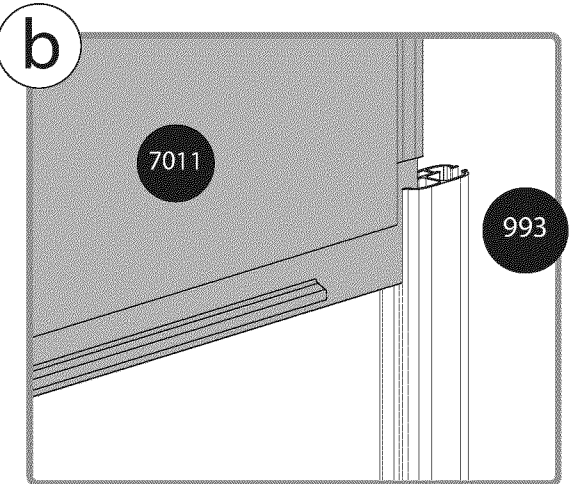
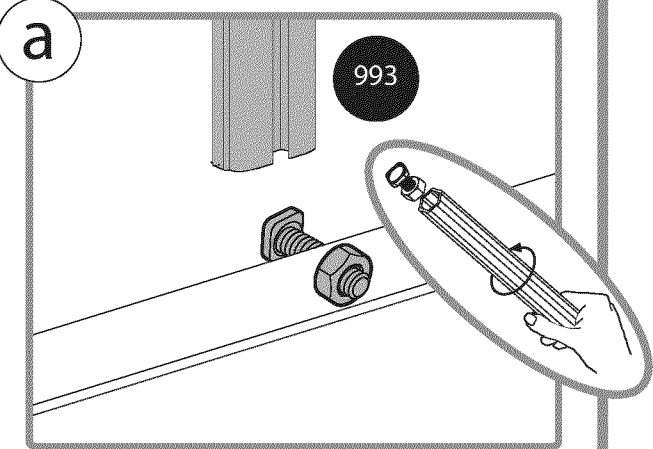
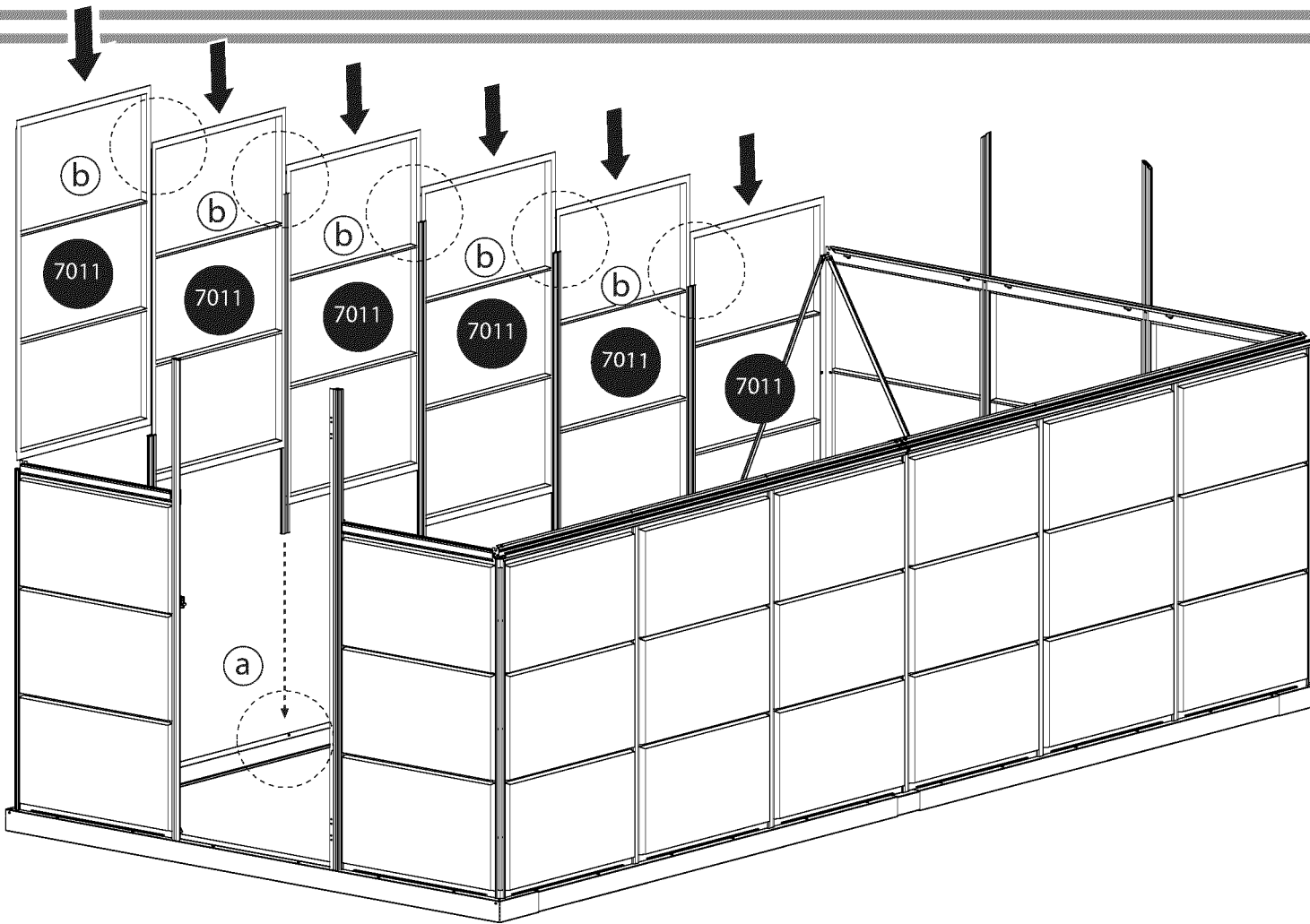

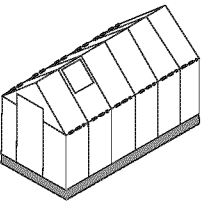

318
PVC

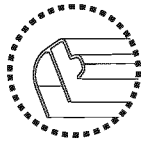

x6

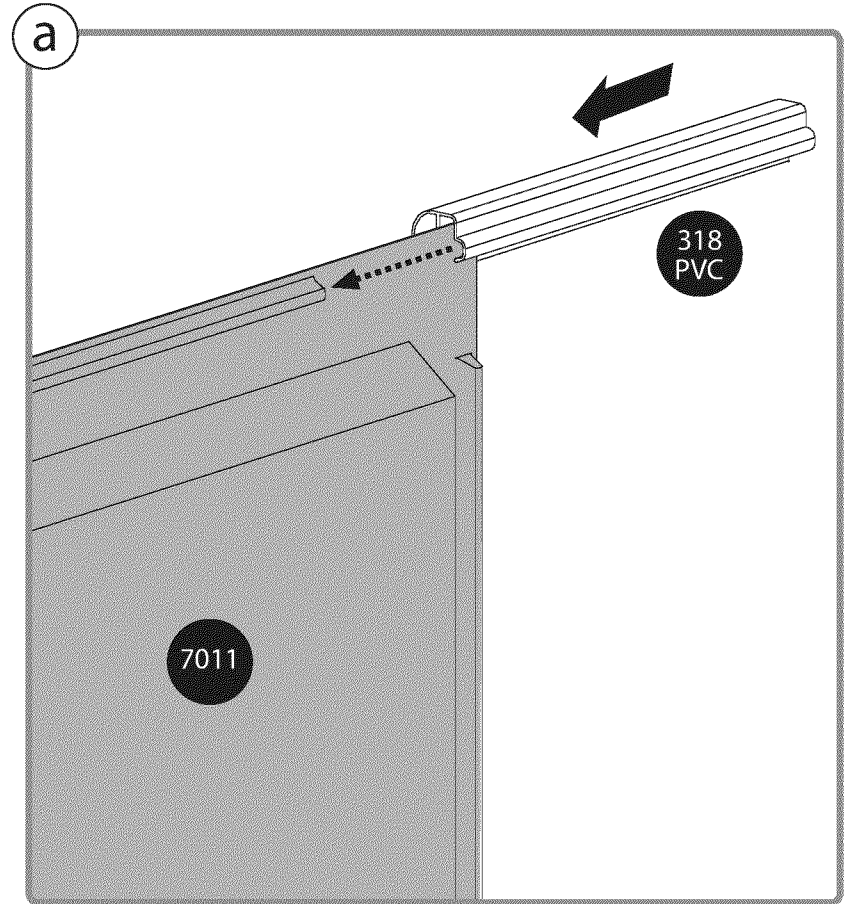
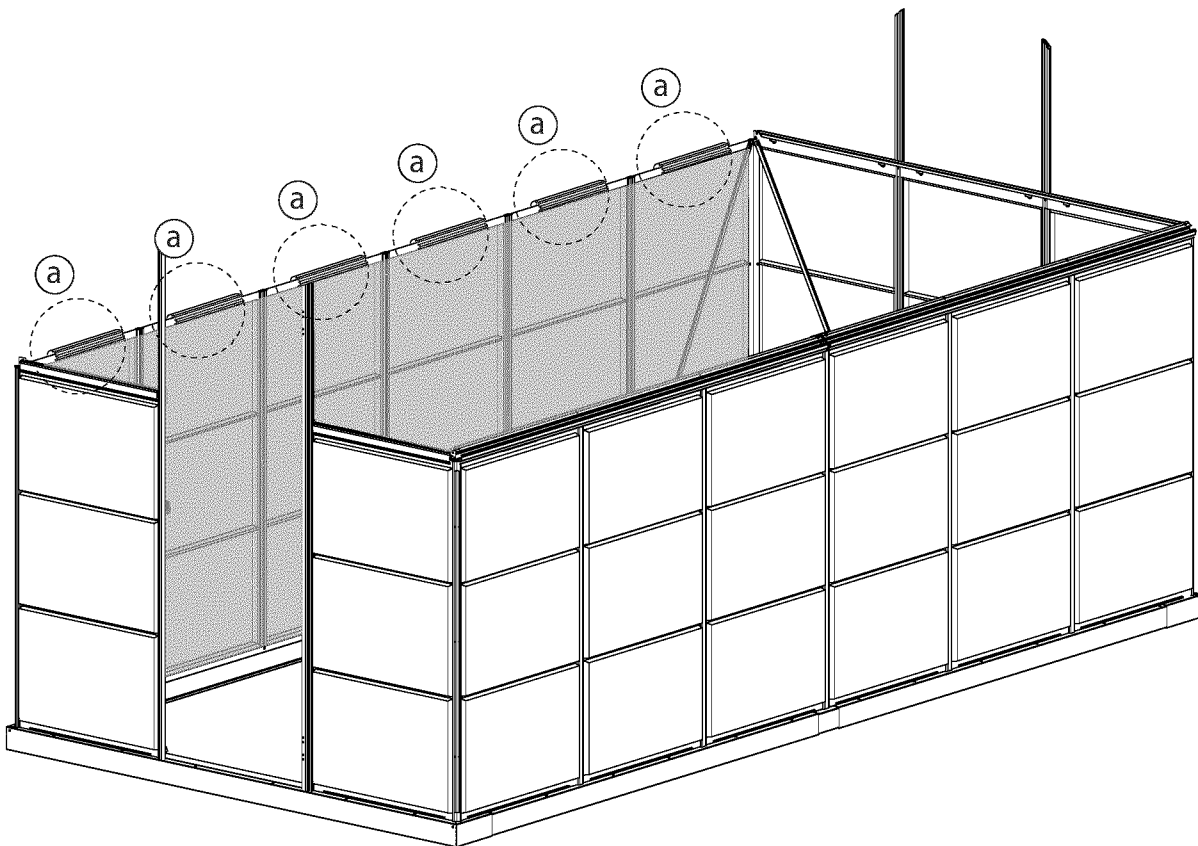



412 

411 

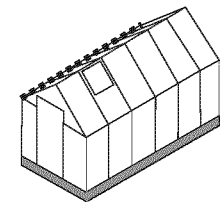

412  x5

411  x5

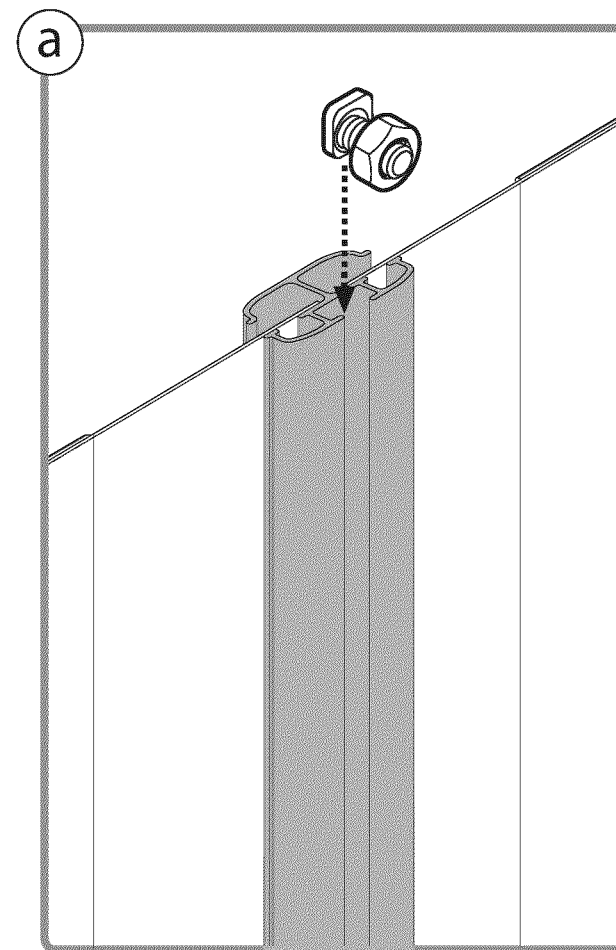
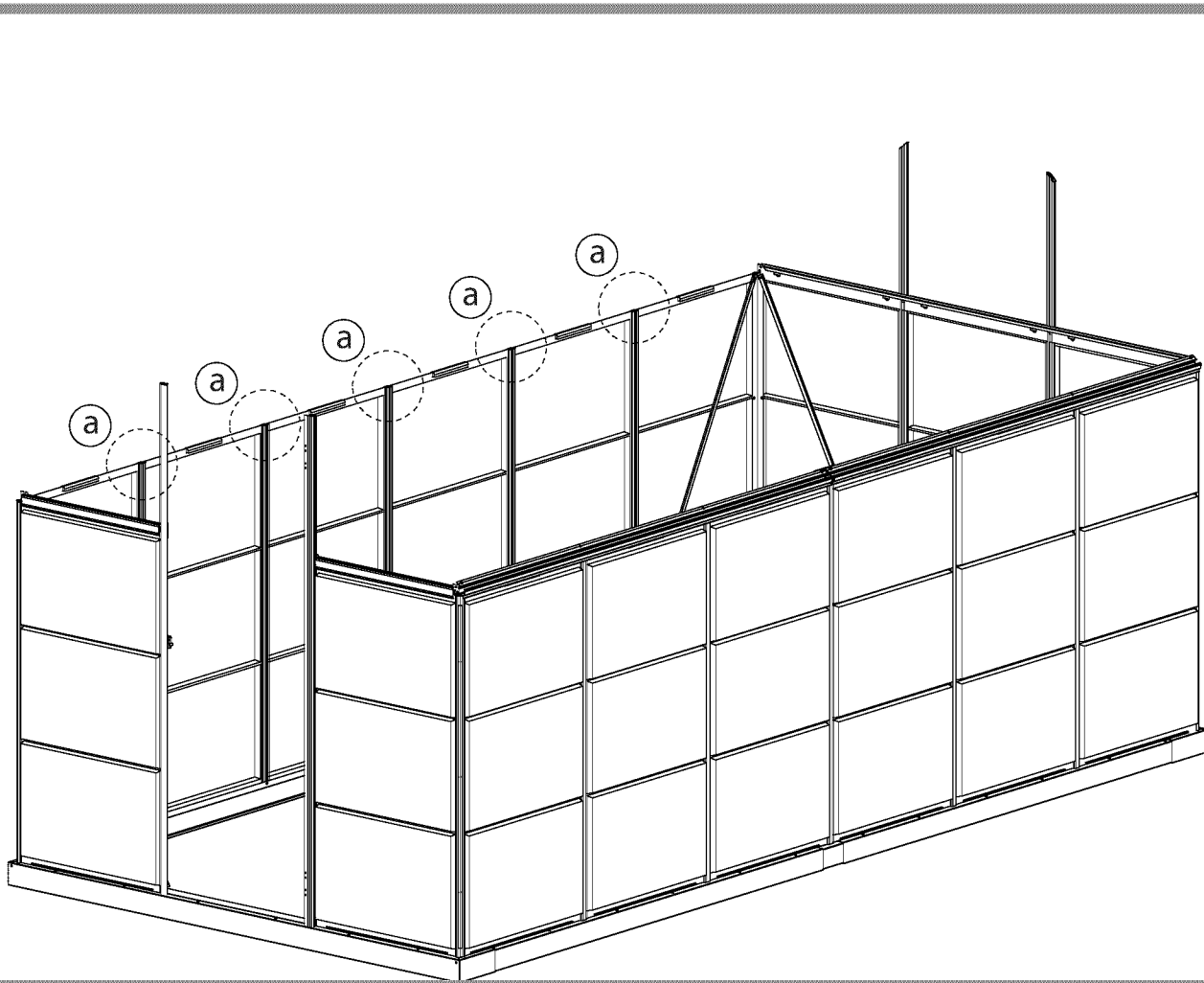

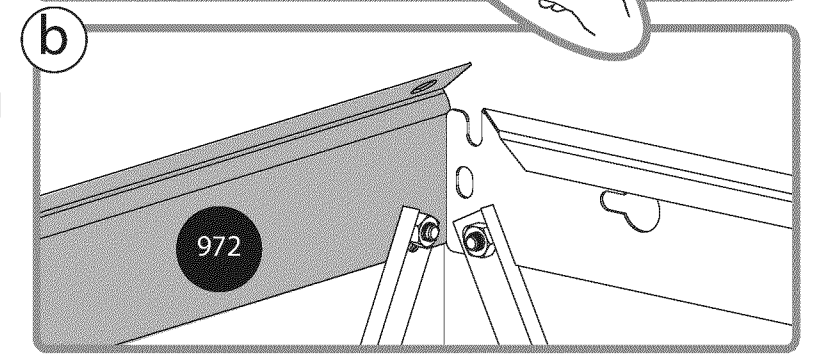
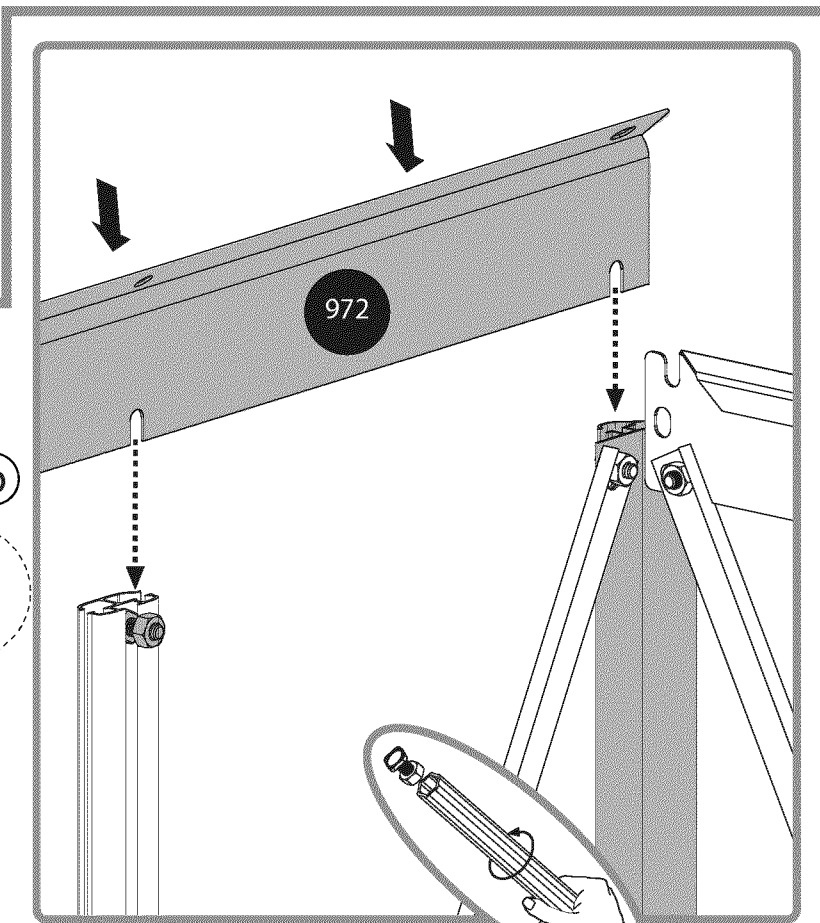
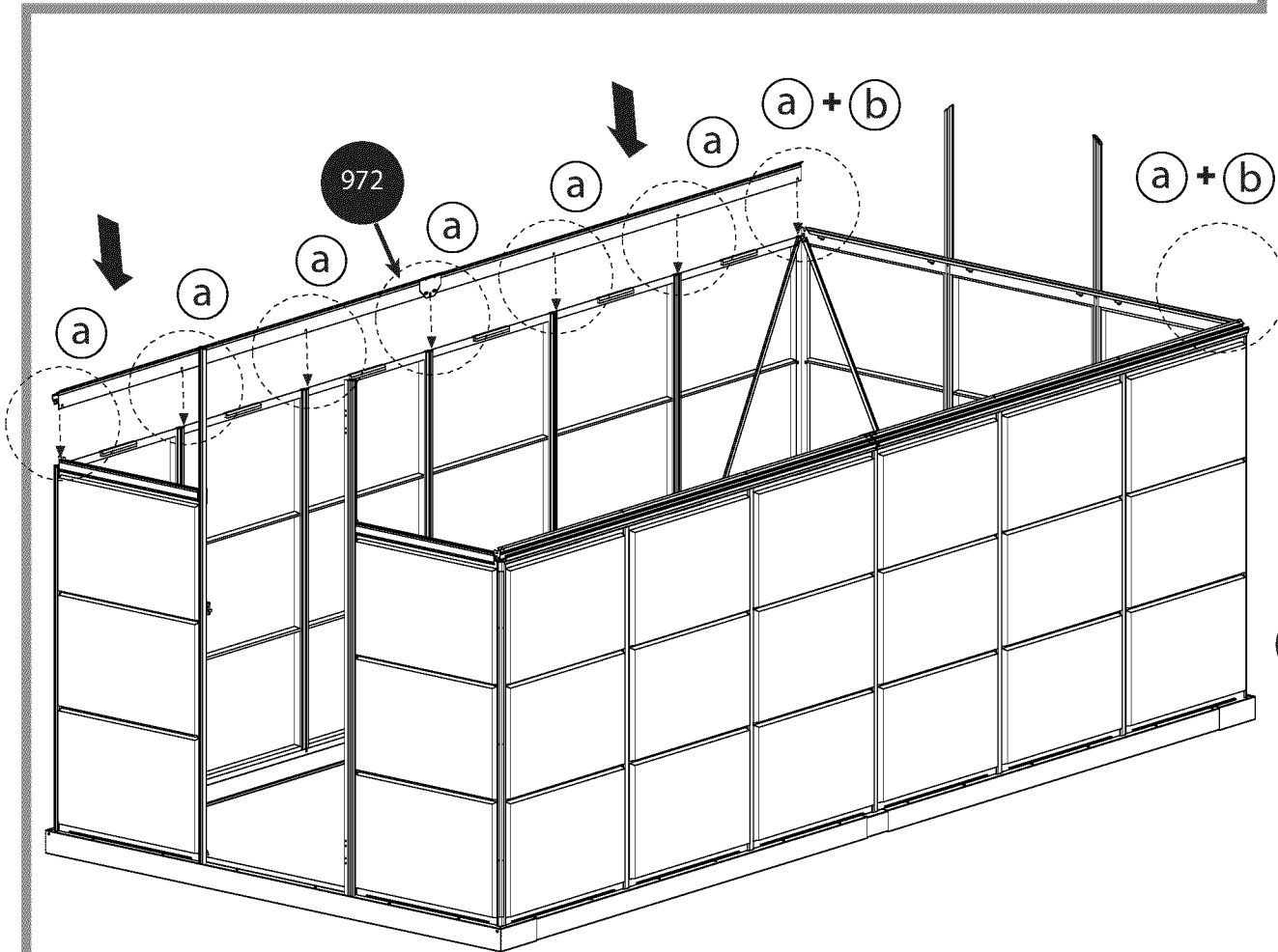
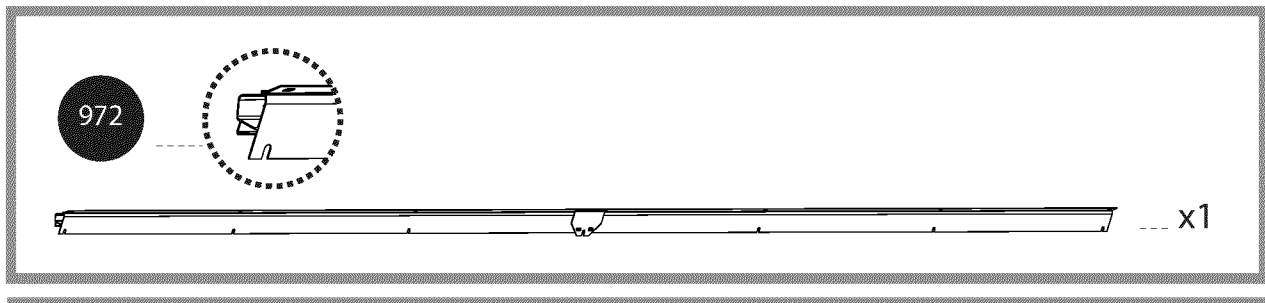
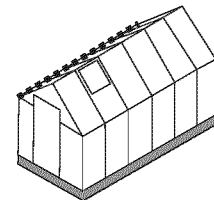

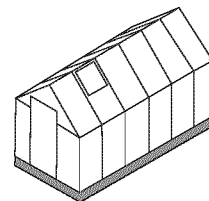

4008



x2

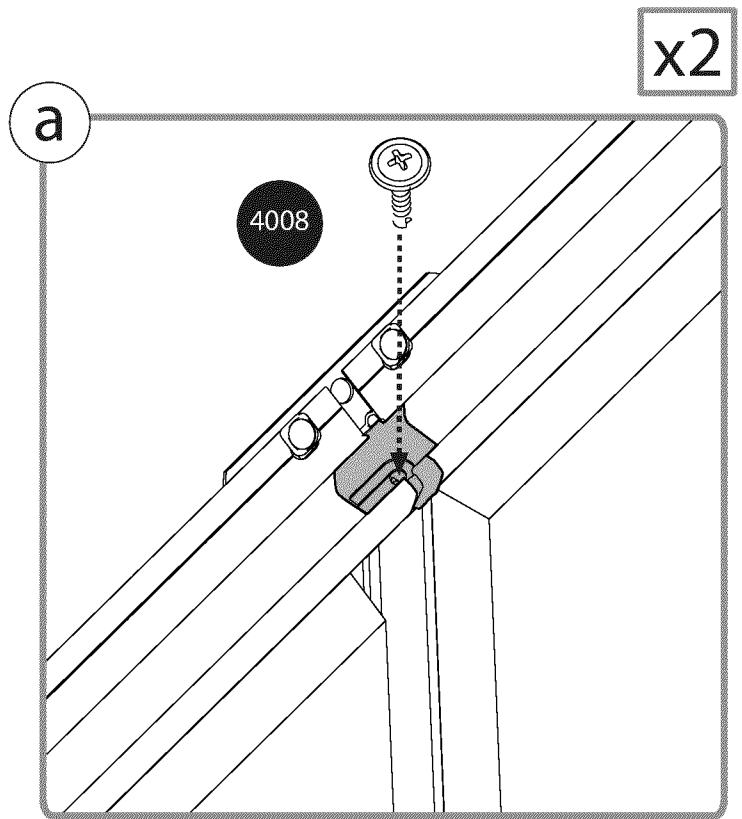
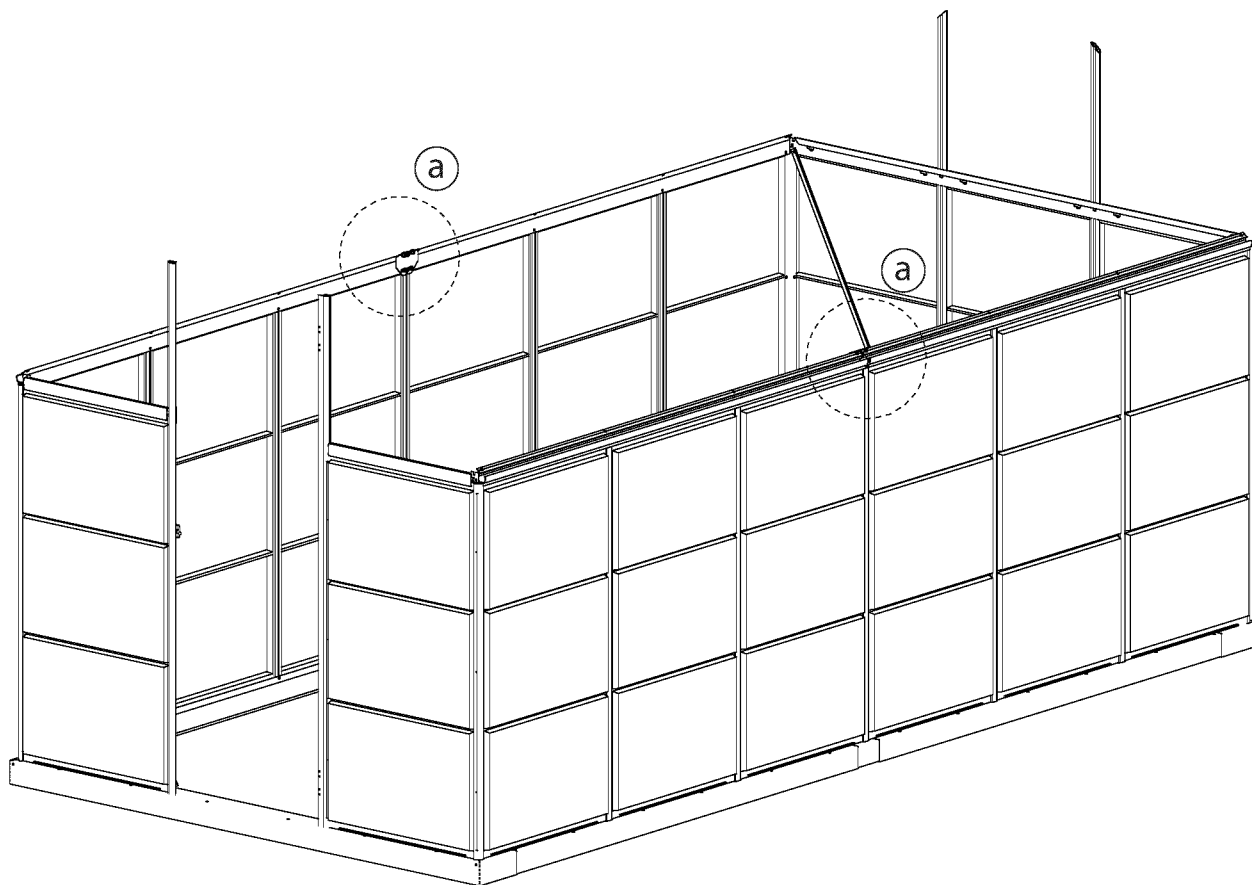

28

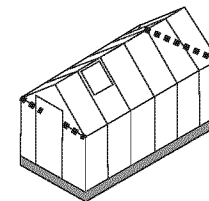

999

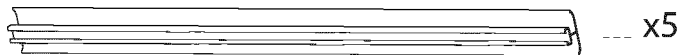

x5

411



x10

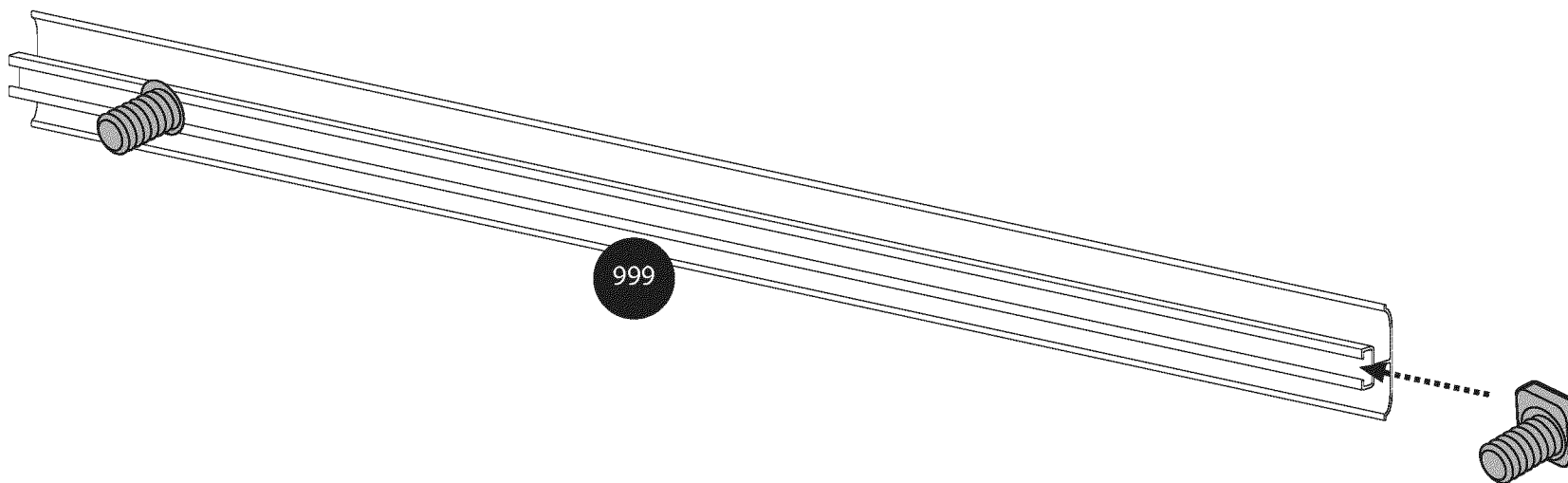

999

x5

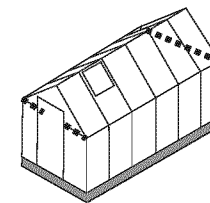

999

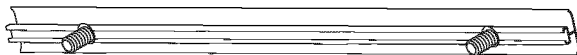

x5

412



x10

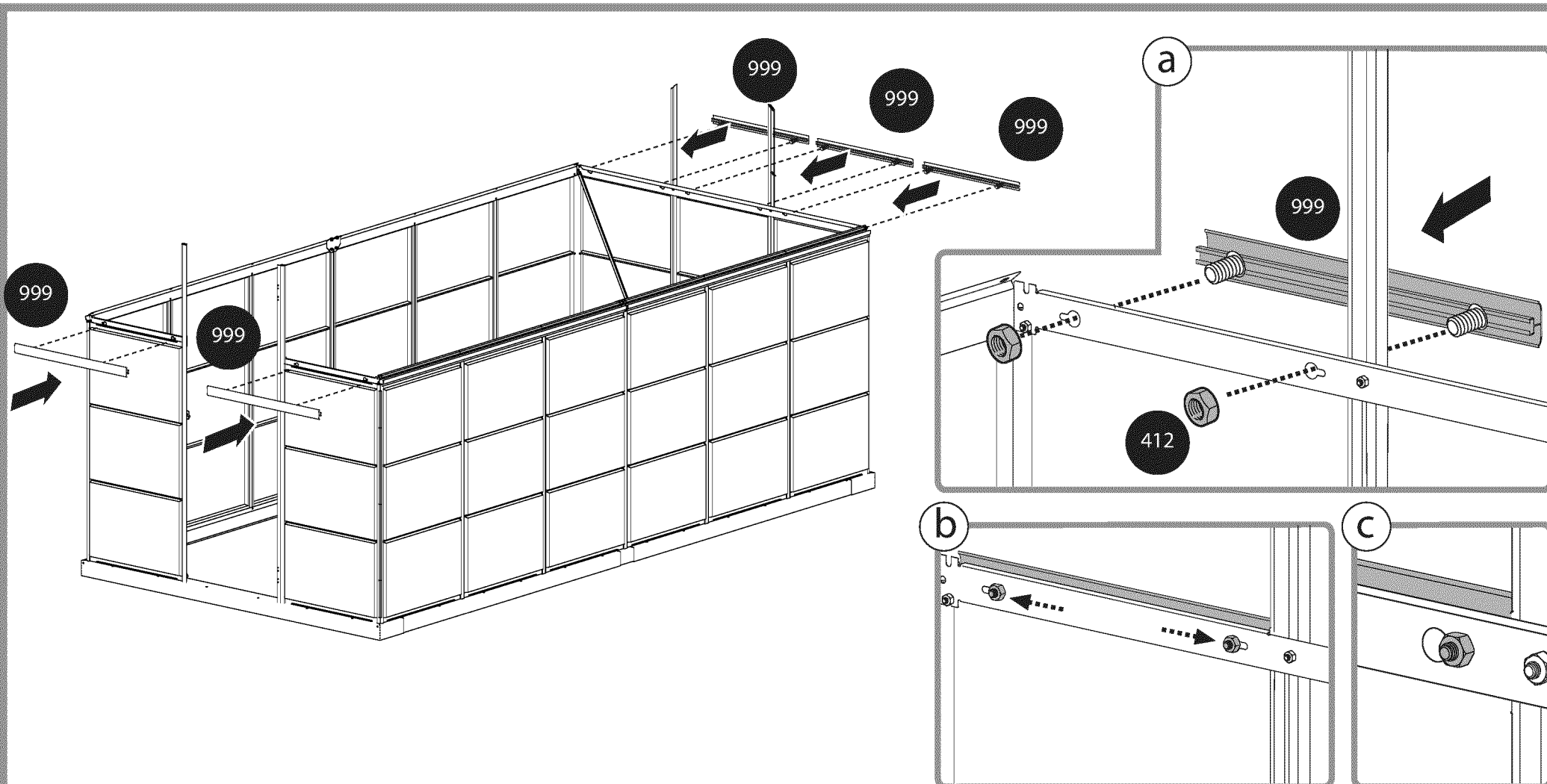

30

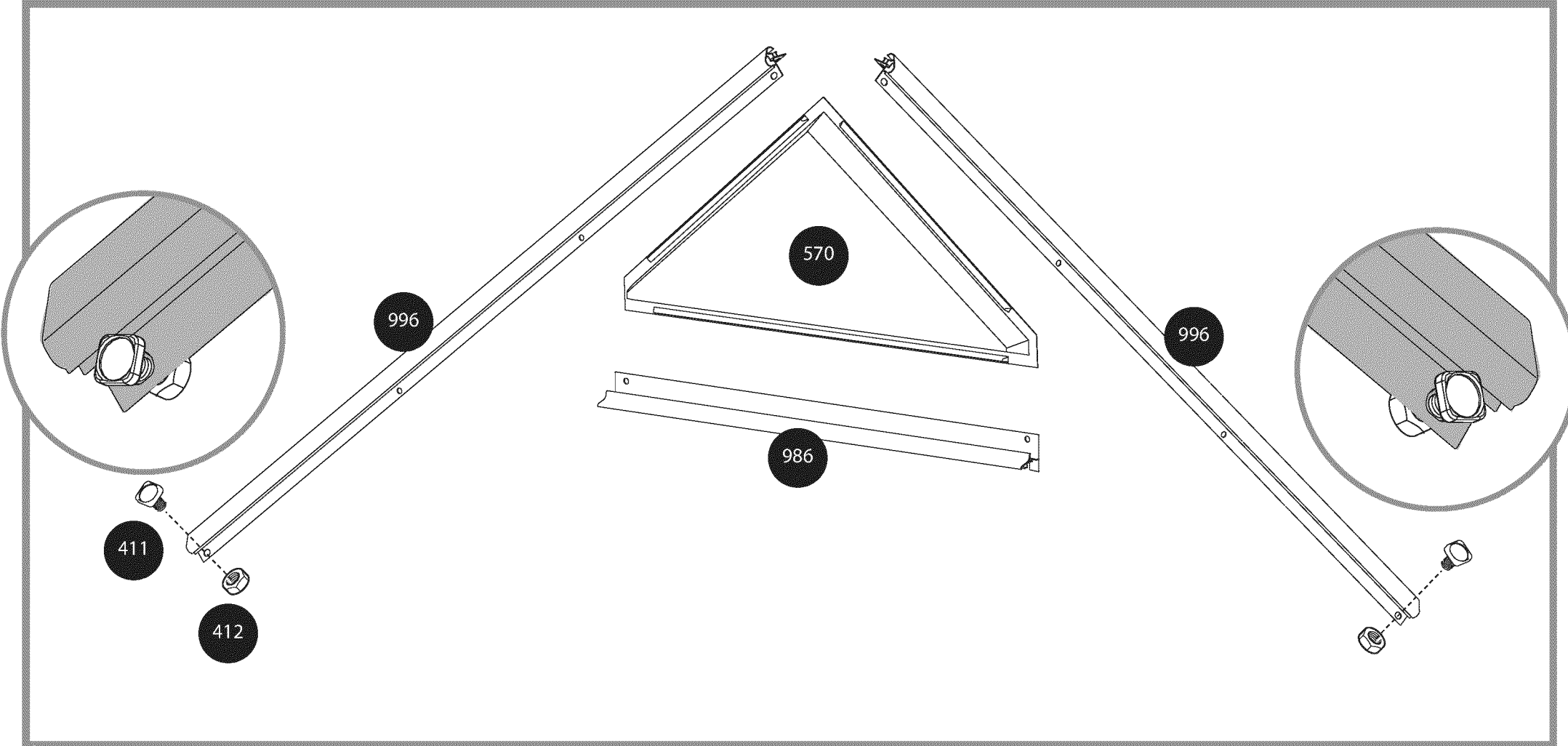
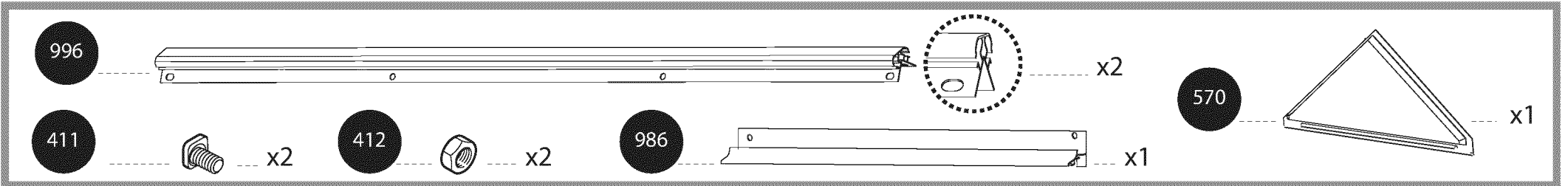
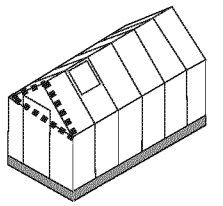

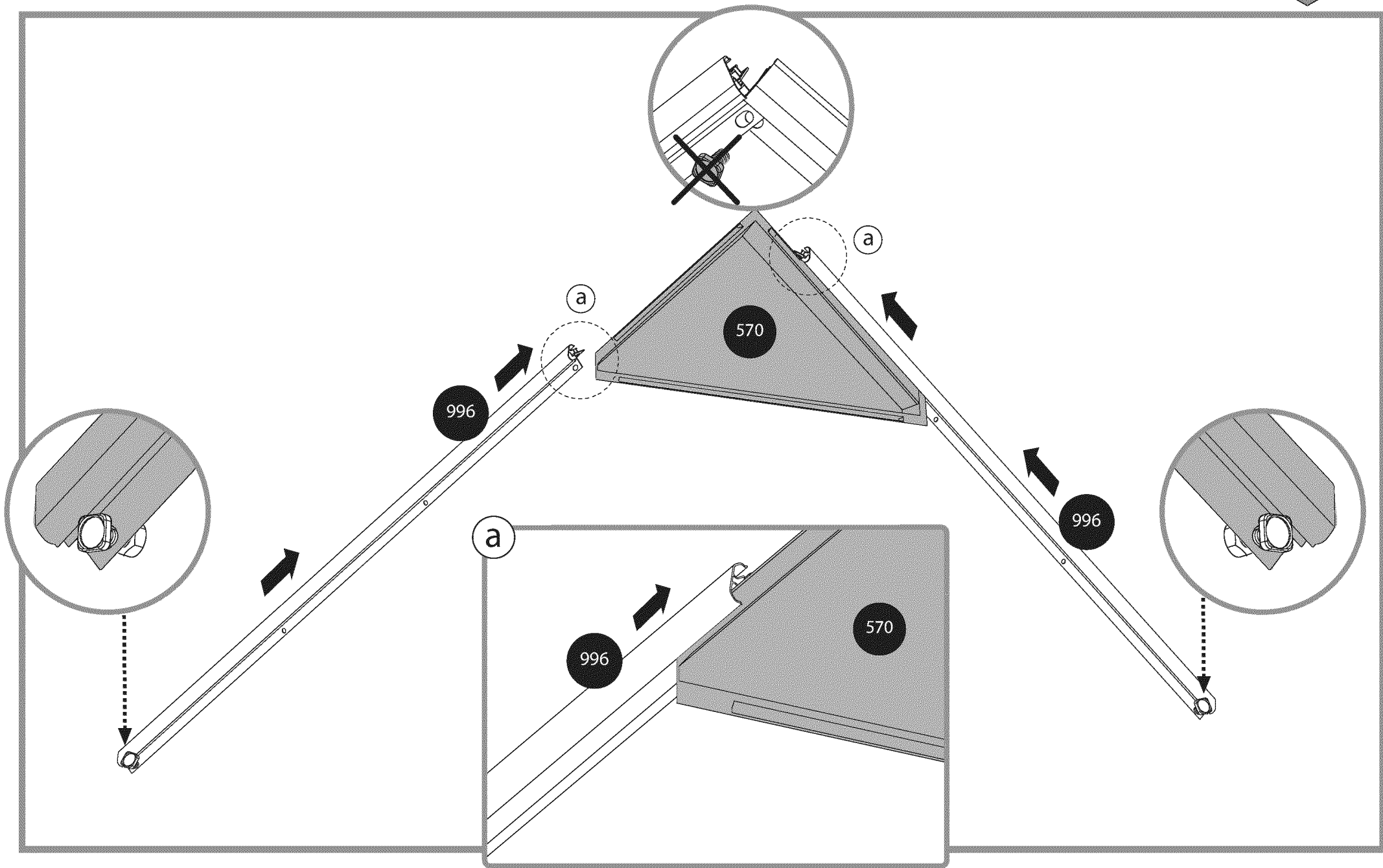
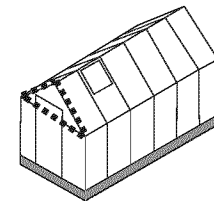
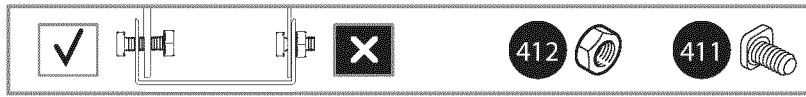

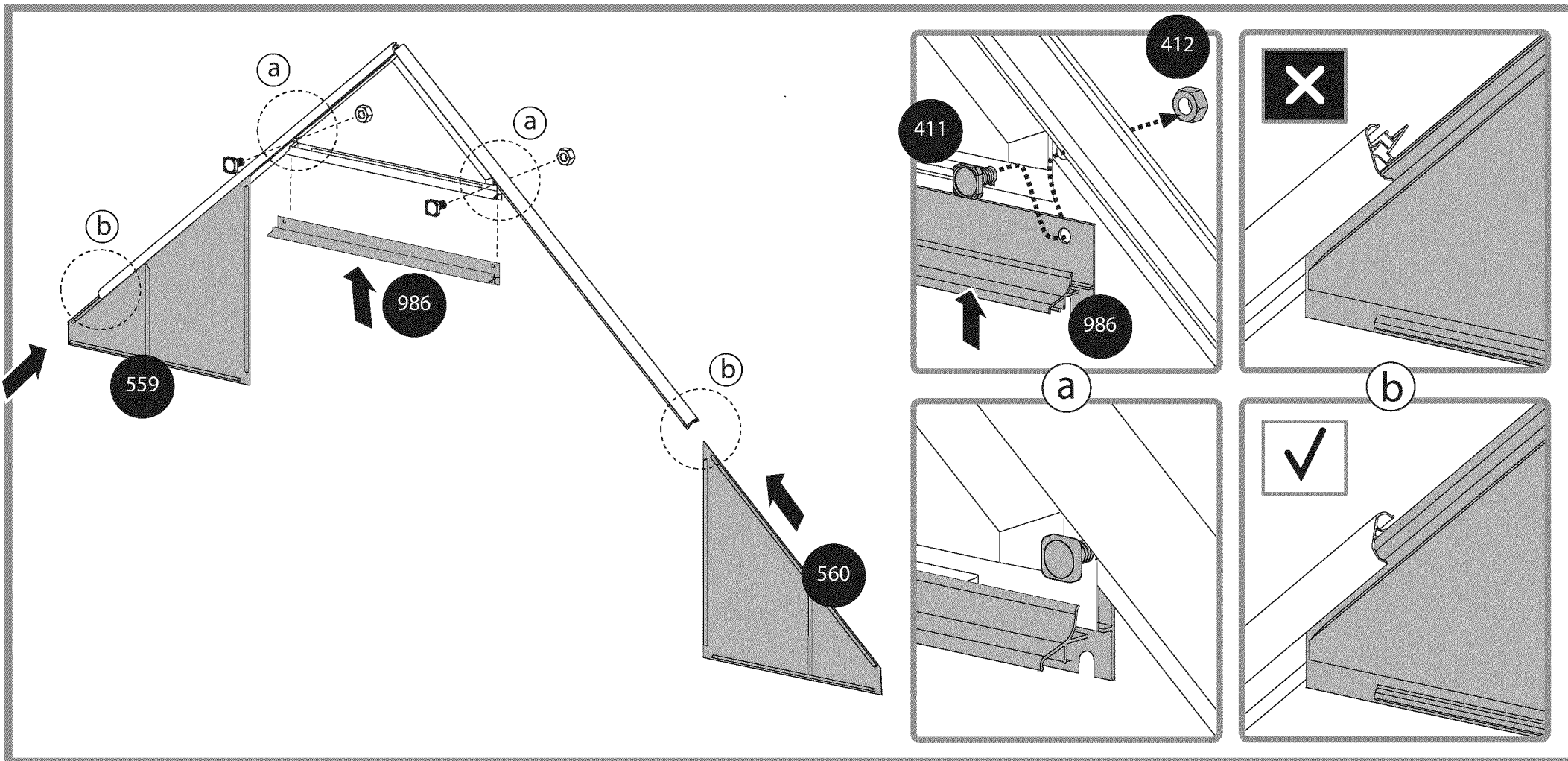
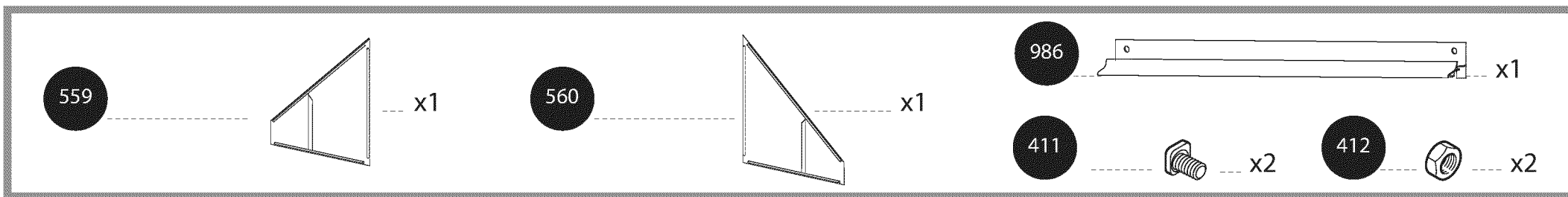
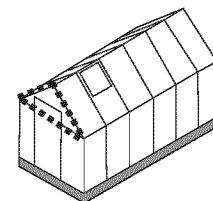

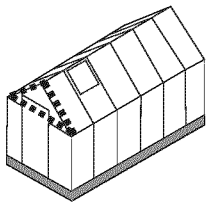

411  x4 412  x4

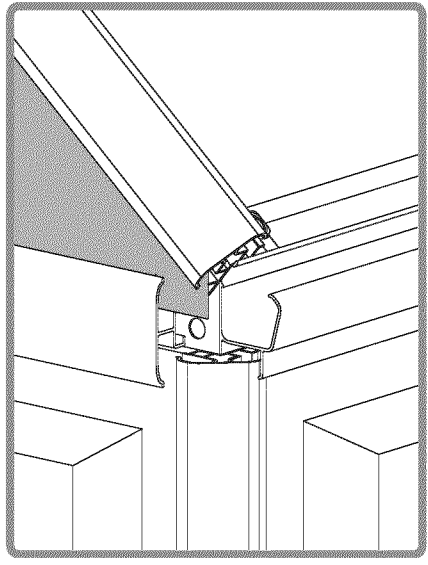
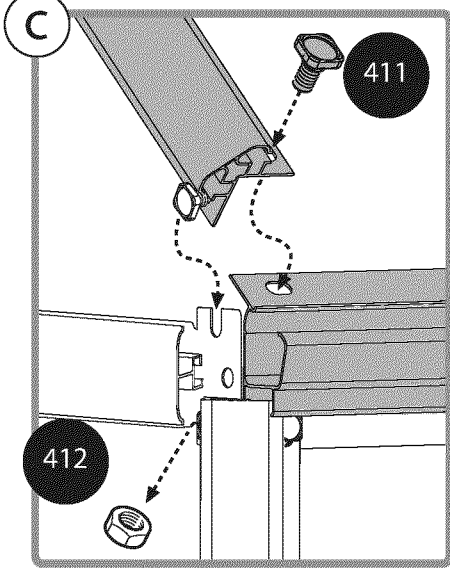
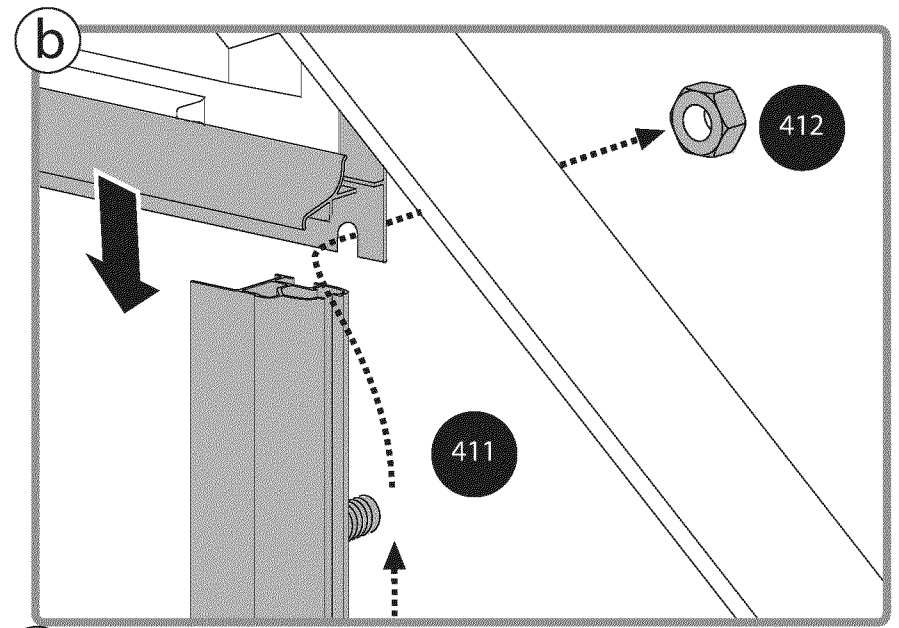
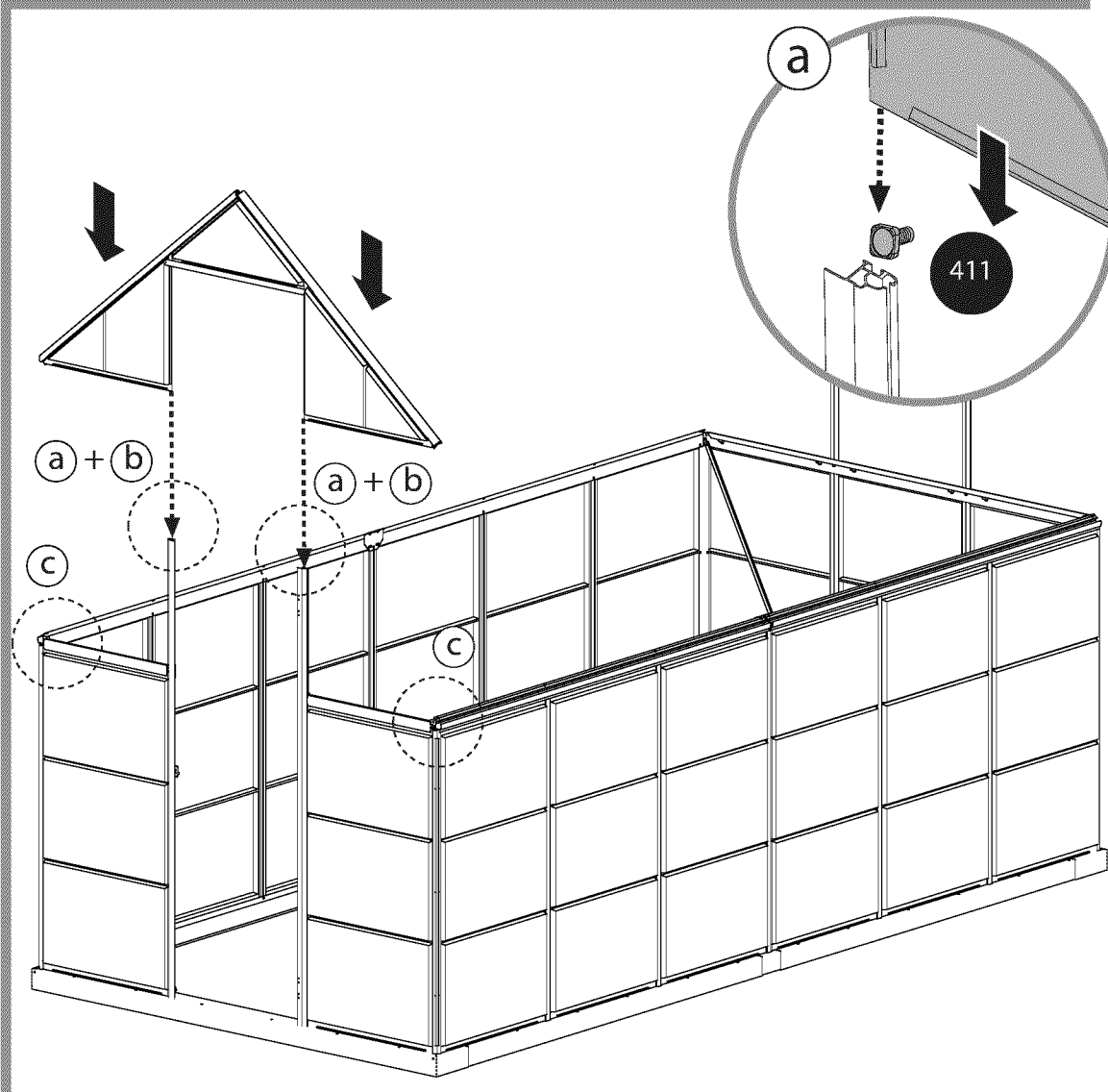

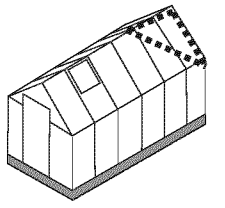

559

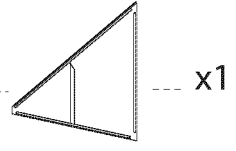

560

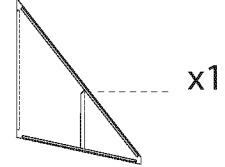

553

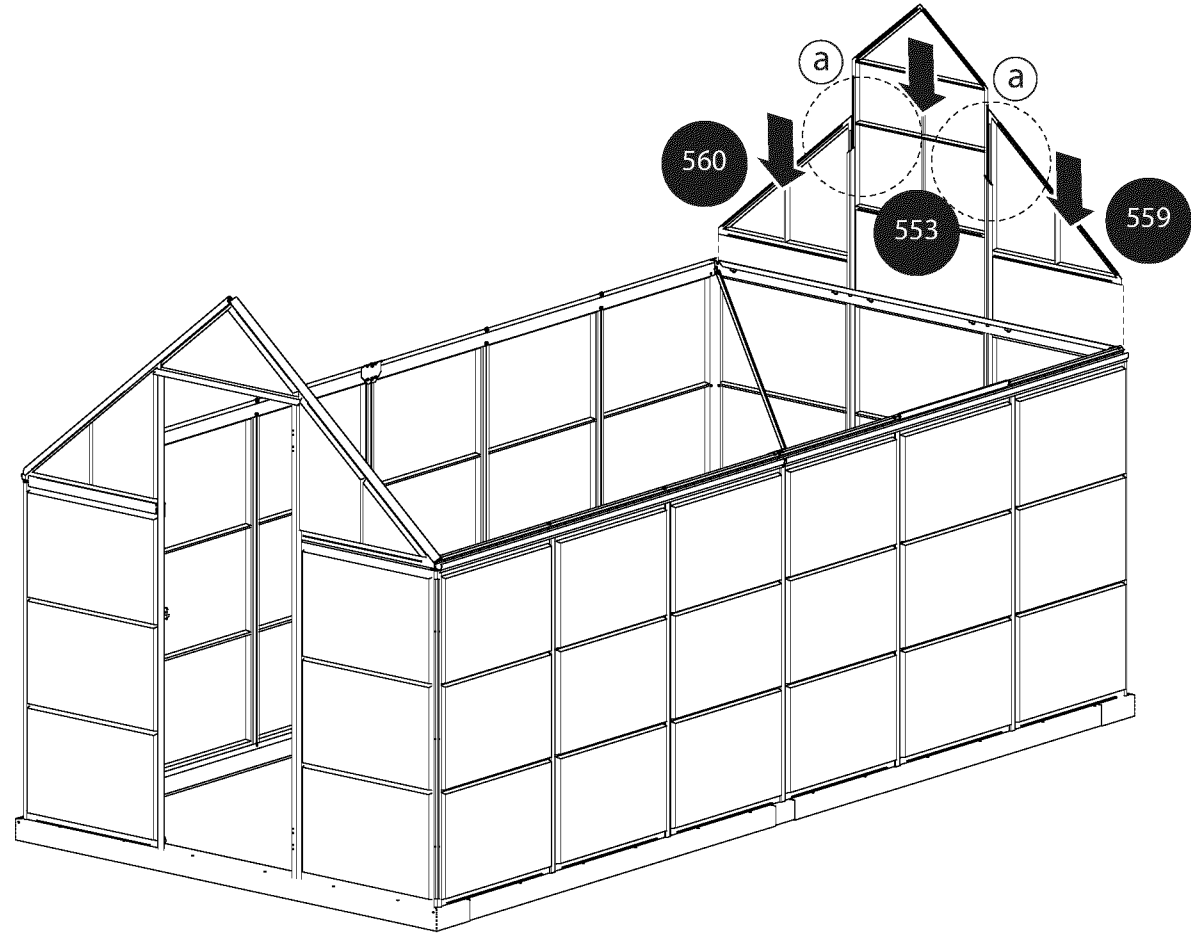
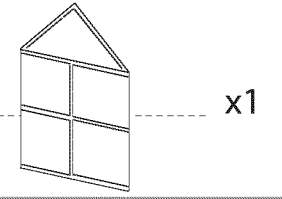

a

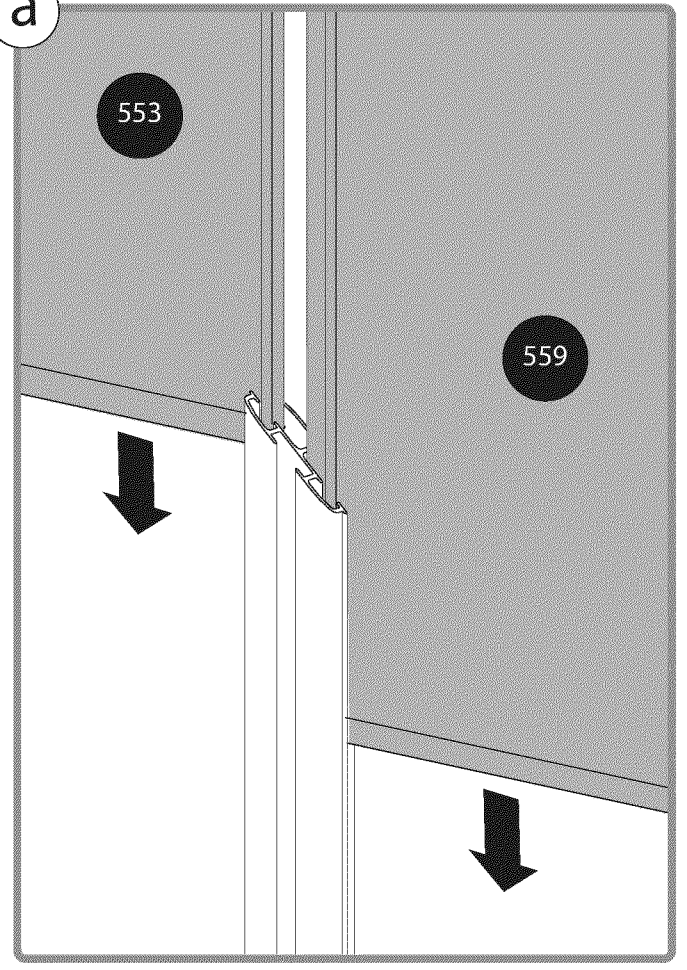

35

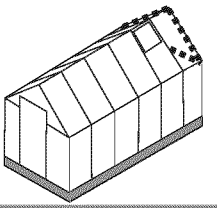

a

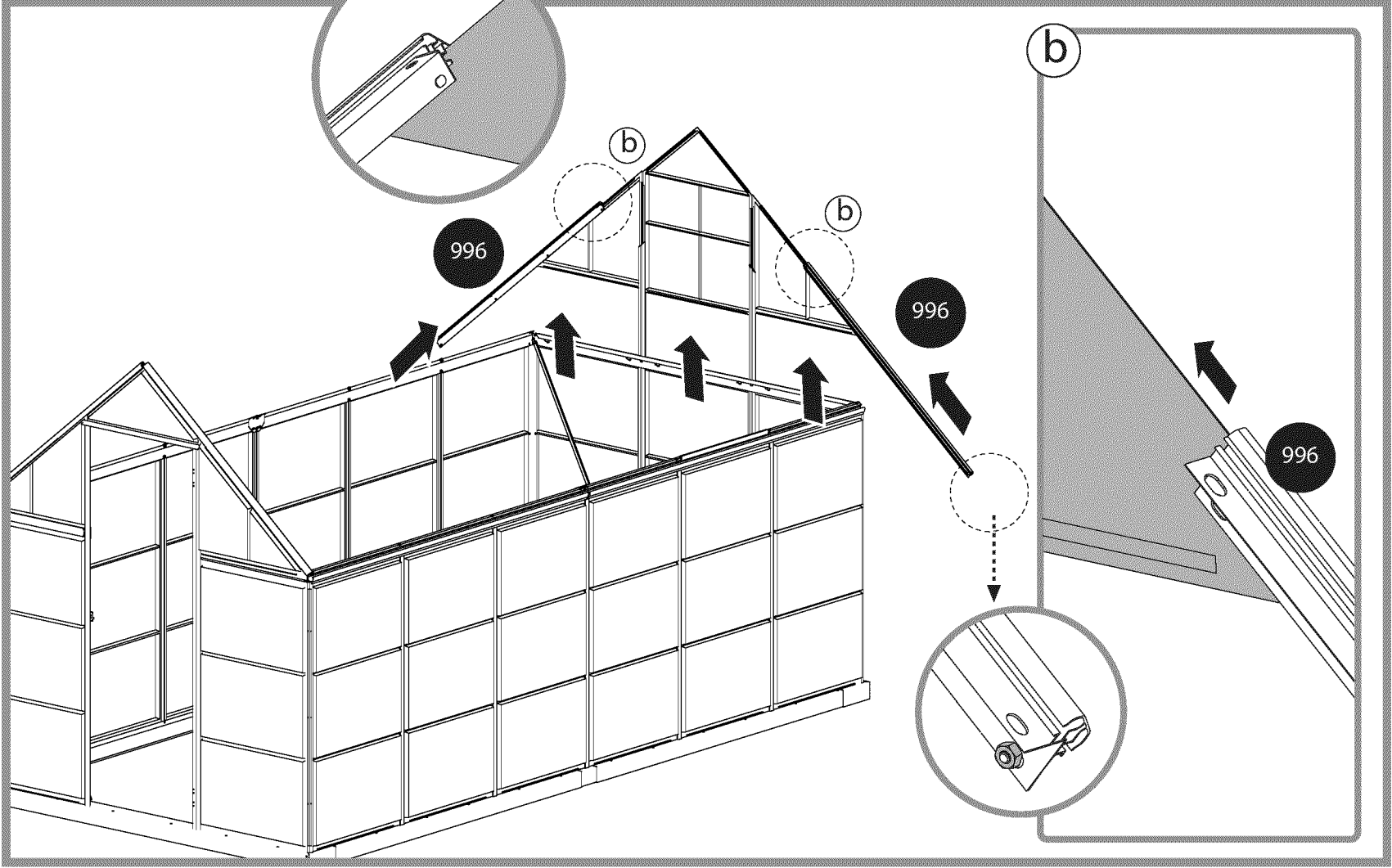
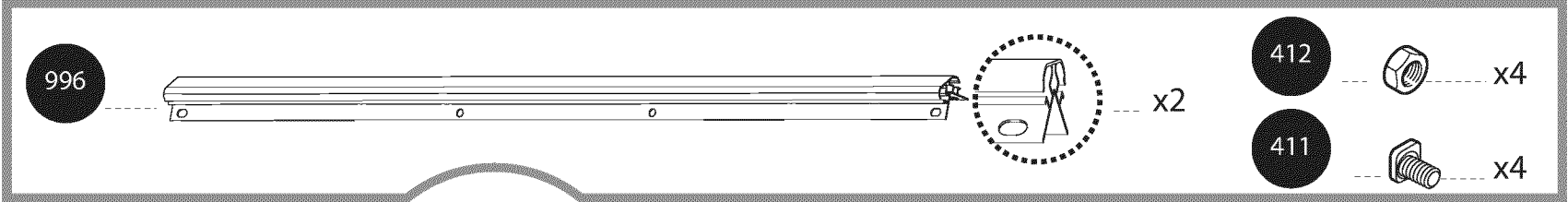
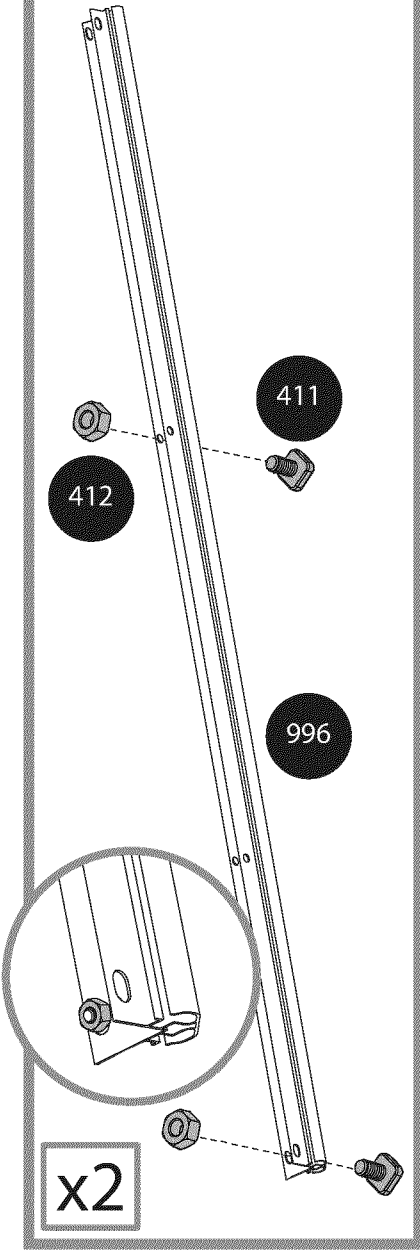

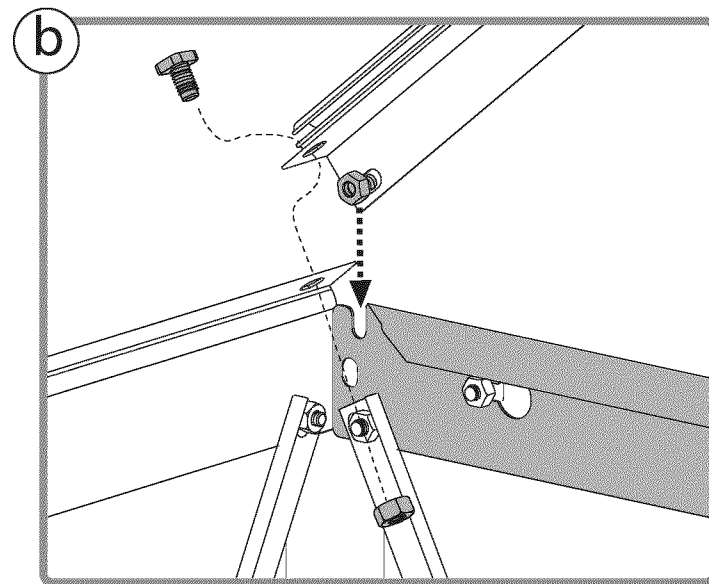
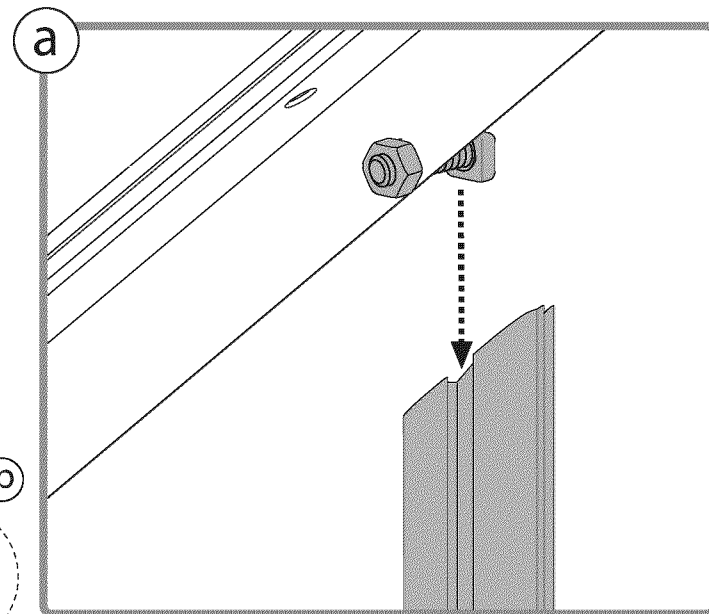
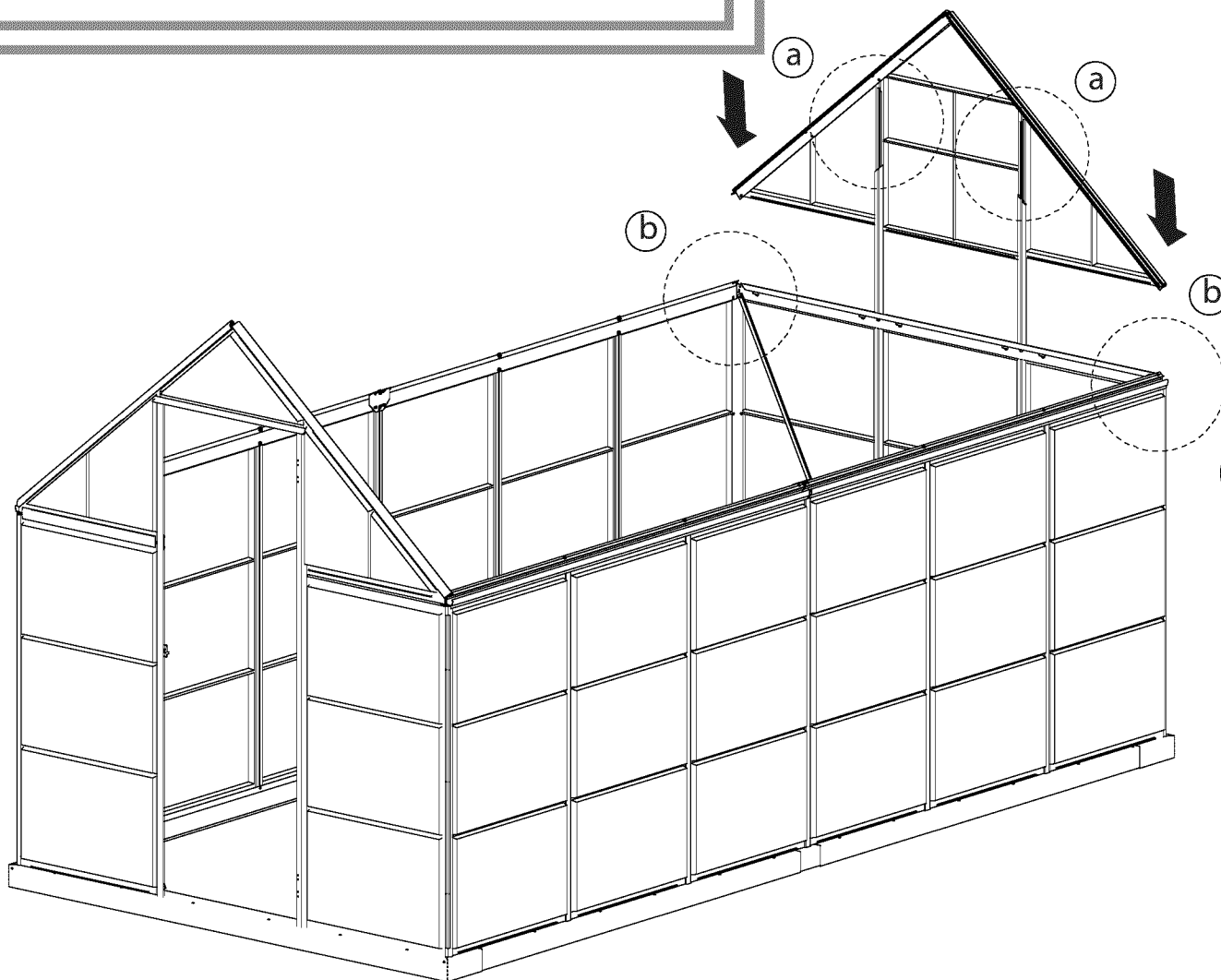
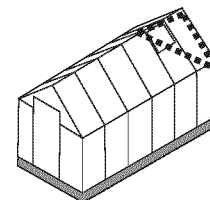

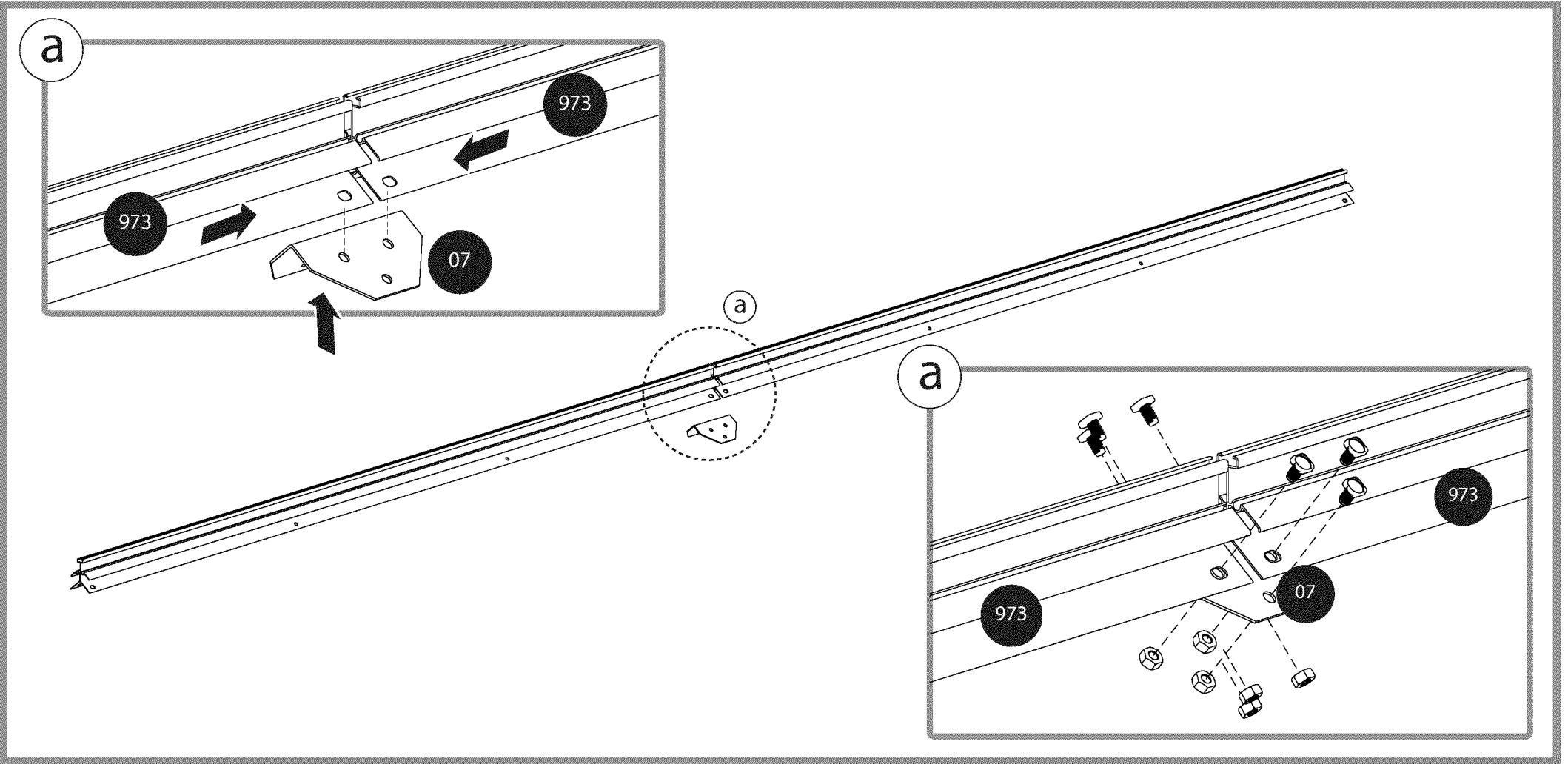
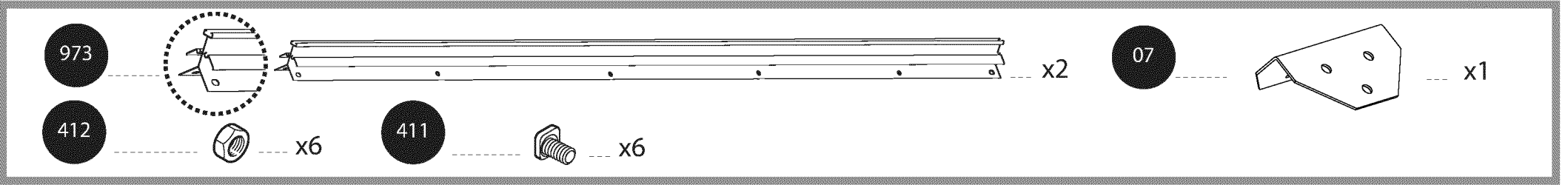
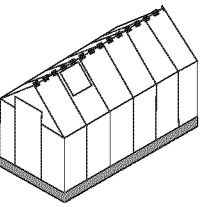

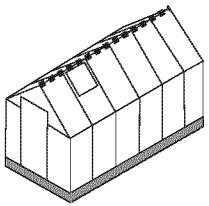

411  x4

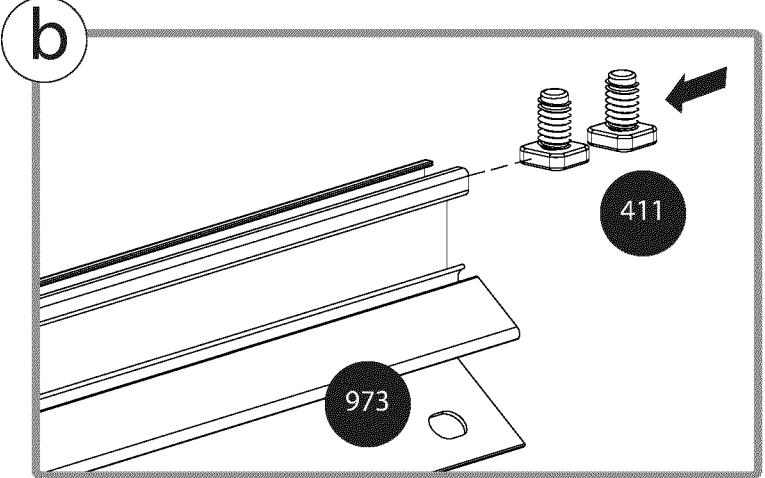
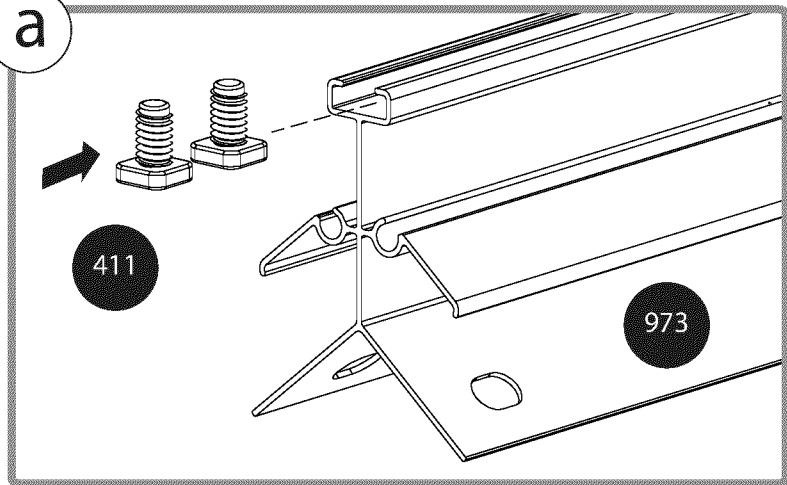
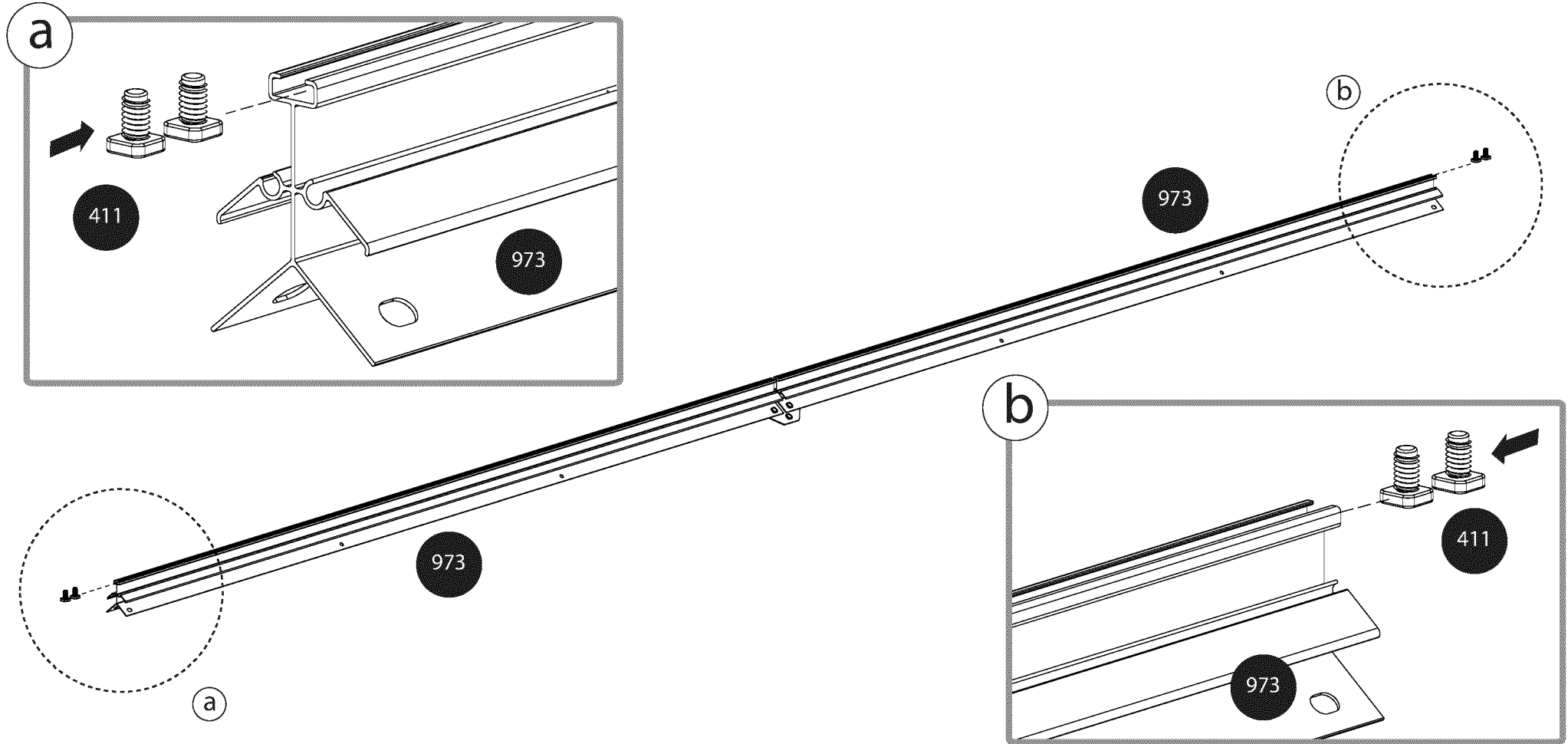

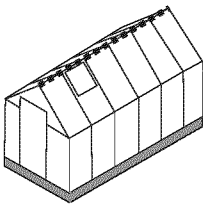

06

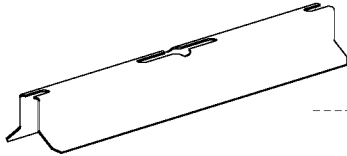

x1

412



x4

a

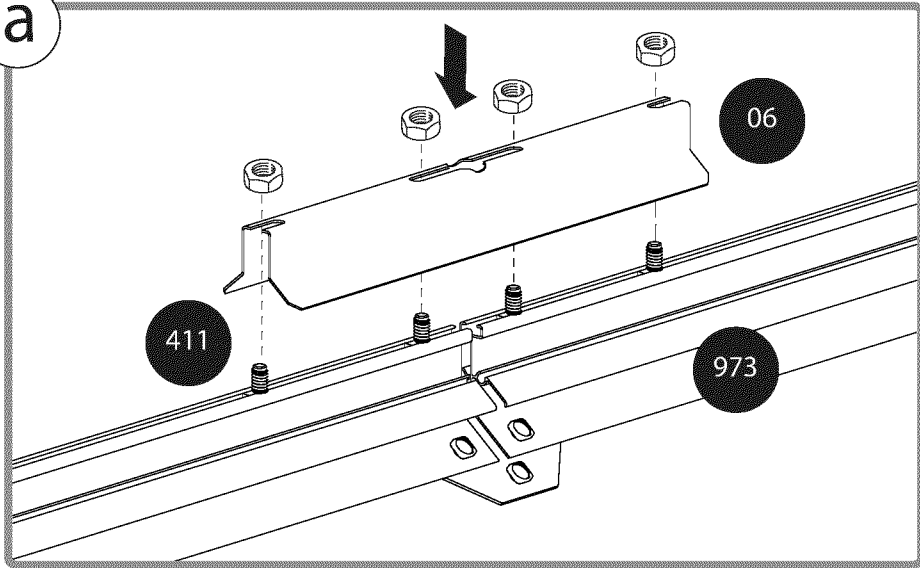

411

973

973

a

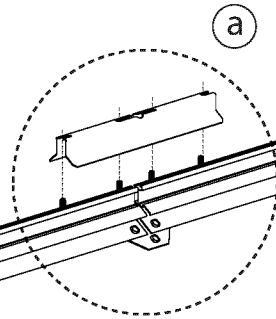

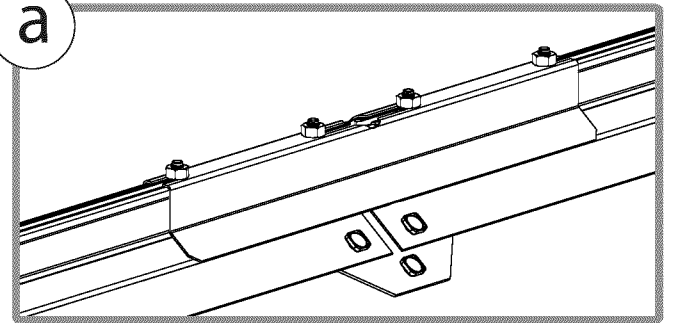

a

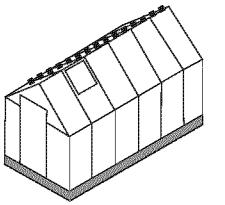

973

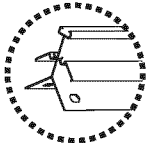
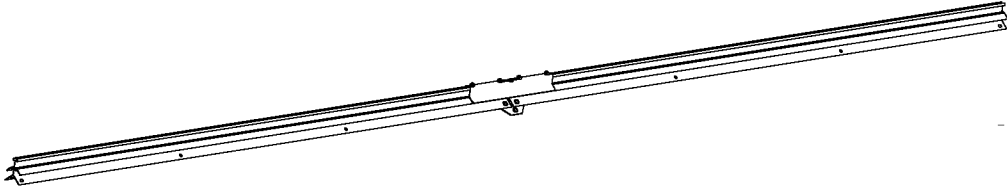

973   x1

412  x4

411  x4

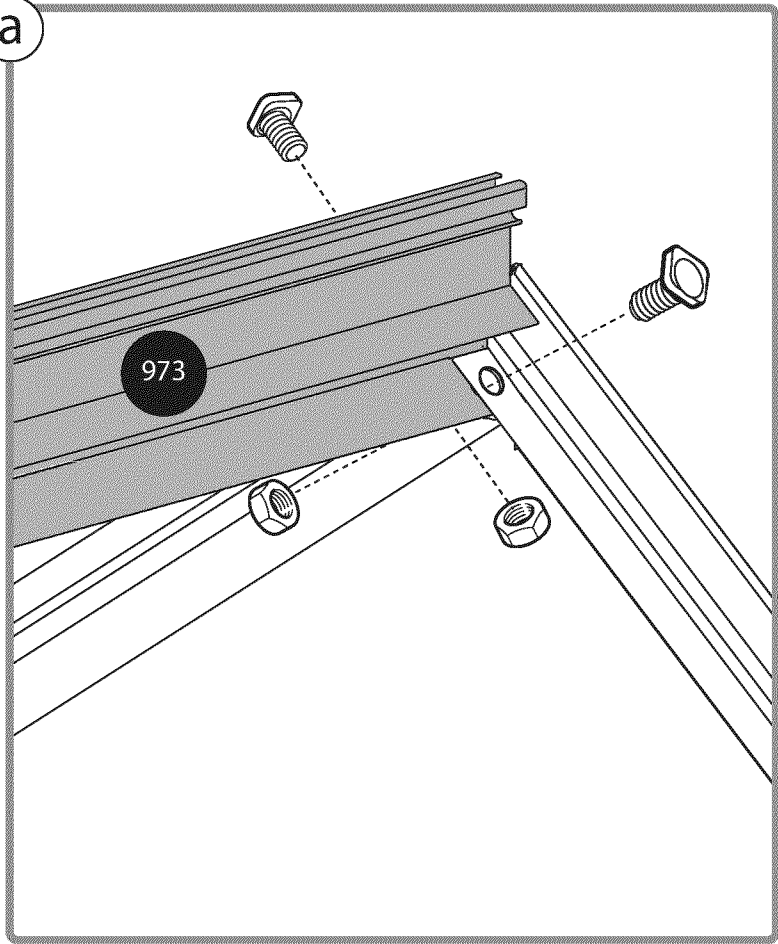
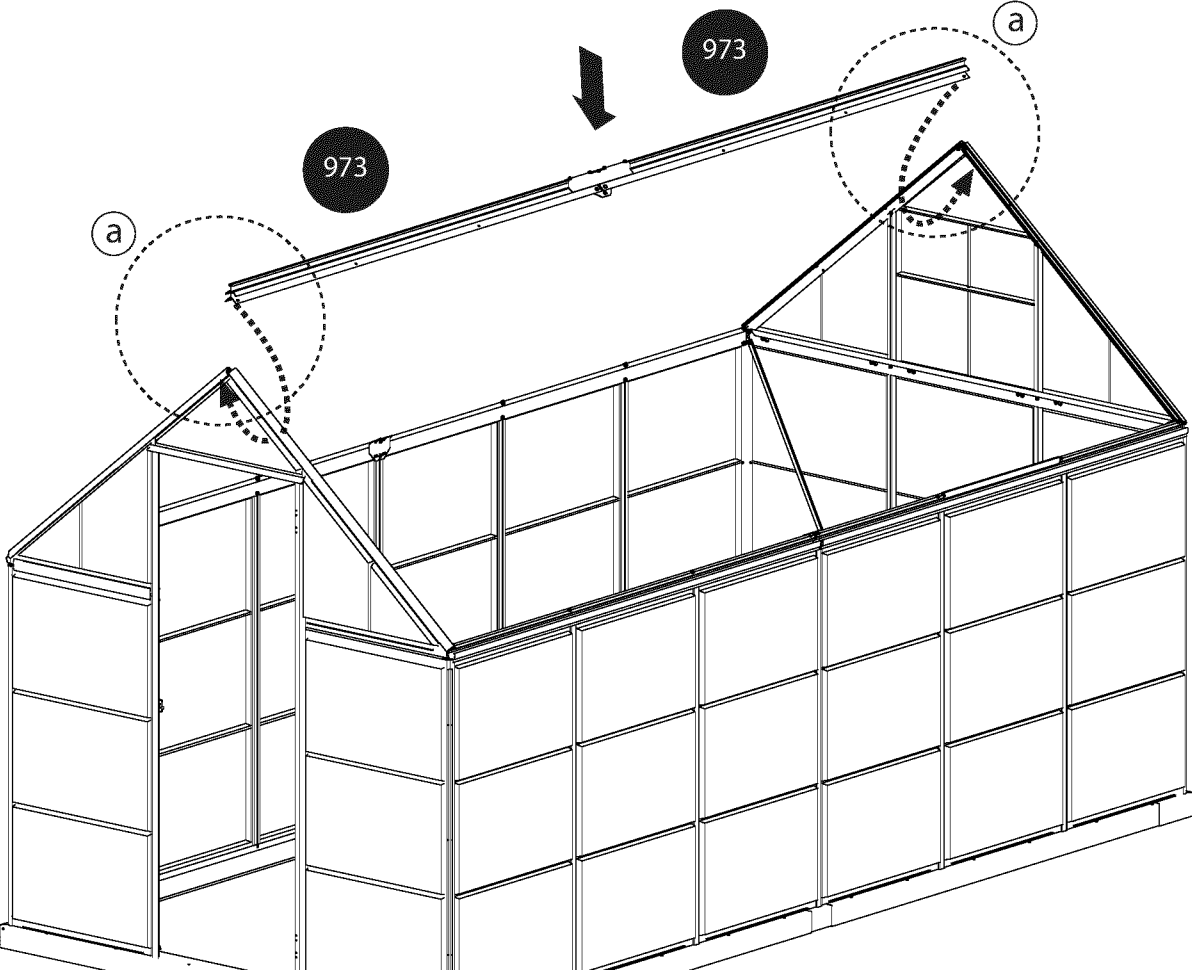

41

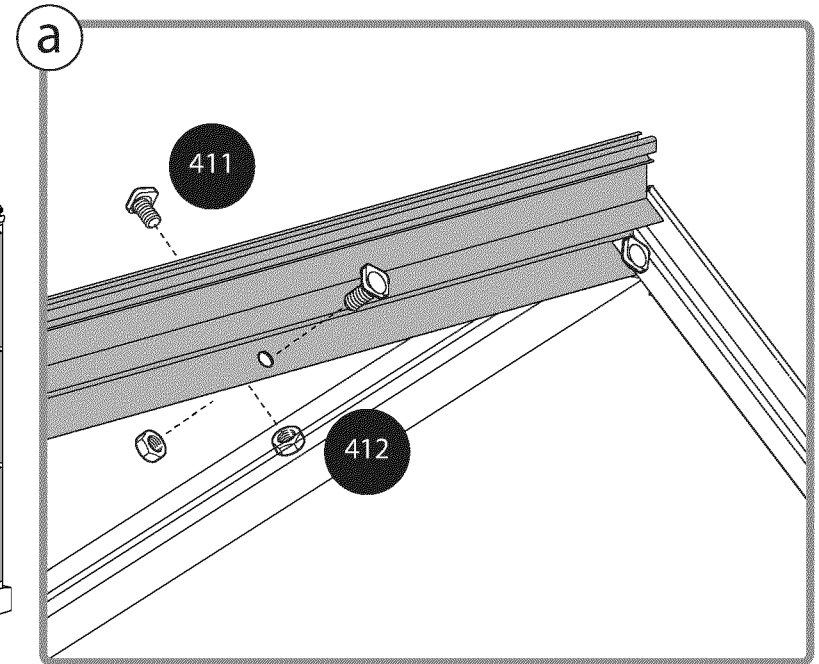
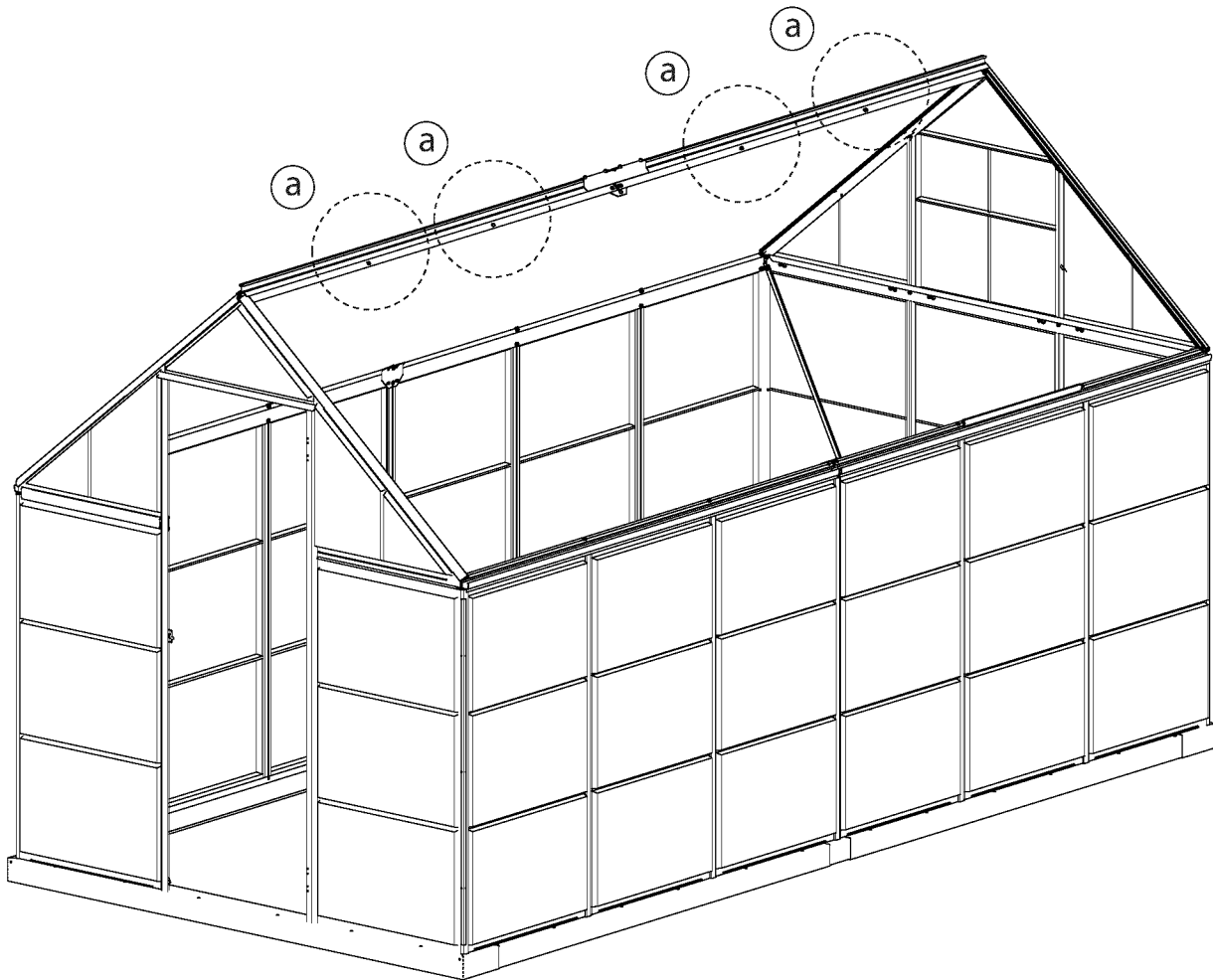
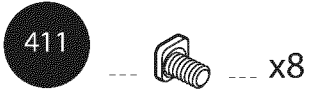
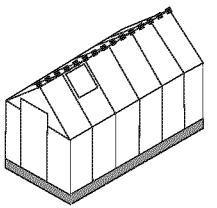

EN Window Location
GR Fenster Standort
FR Fenêtre Emplacement
SP Ventana Ubicación

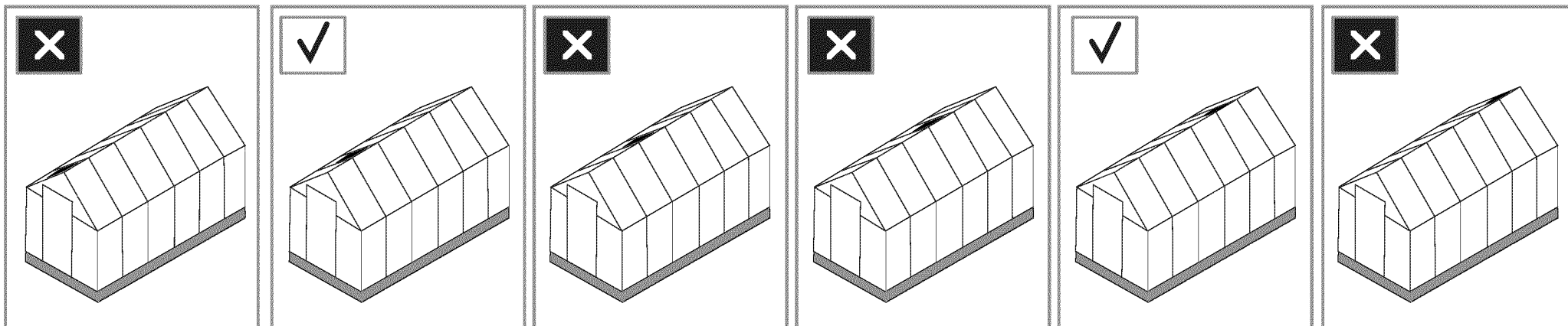
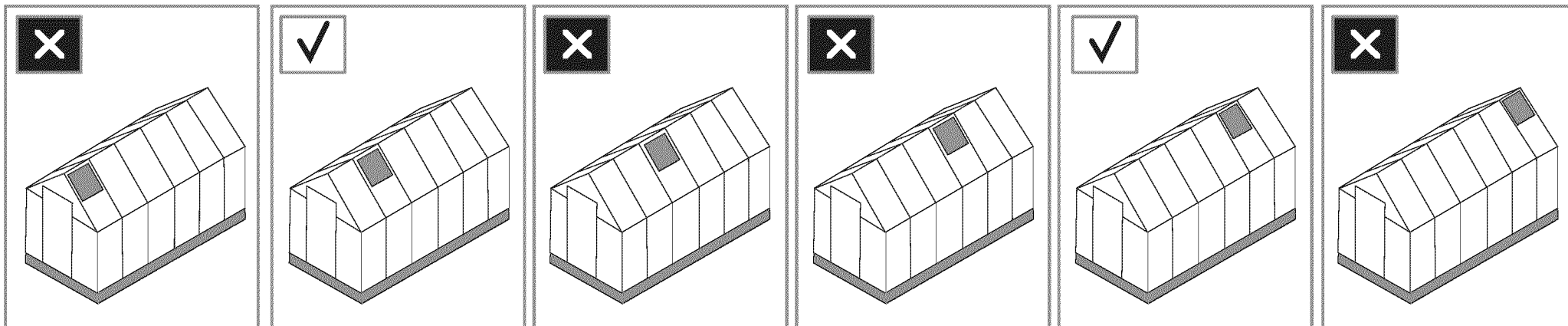
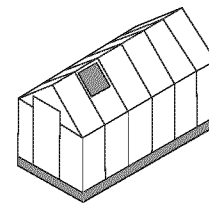

43

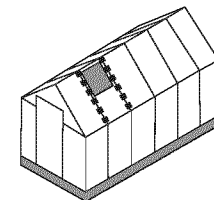

288

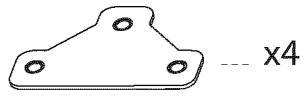

x4

993

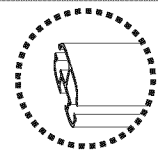

x4

411



x8

412



x8

a

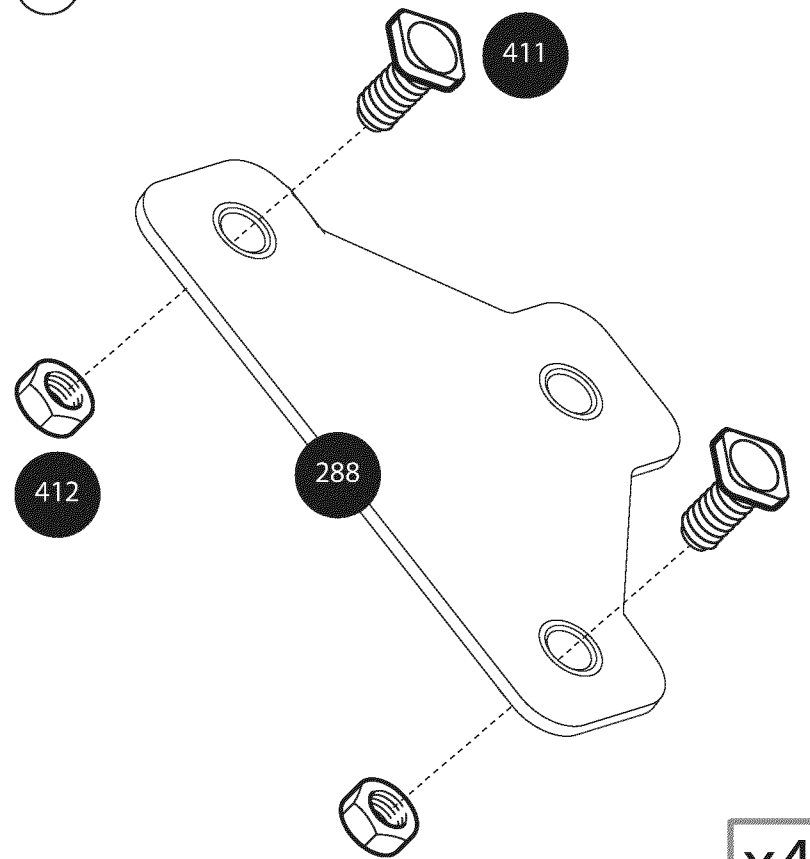

x4

b

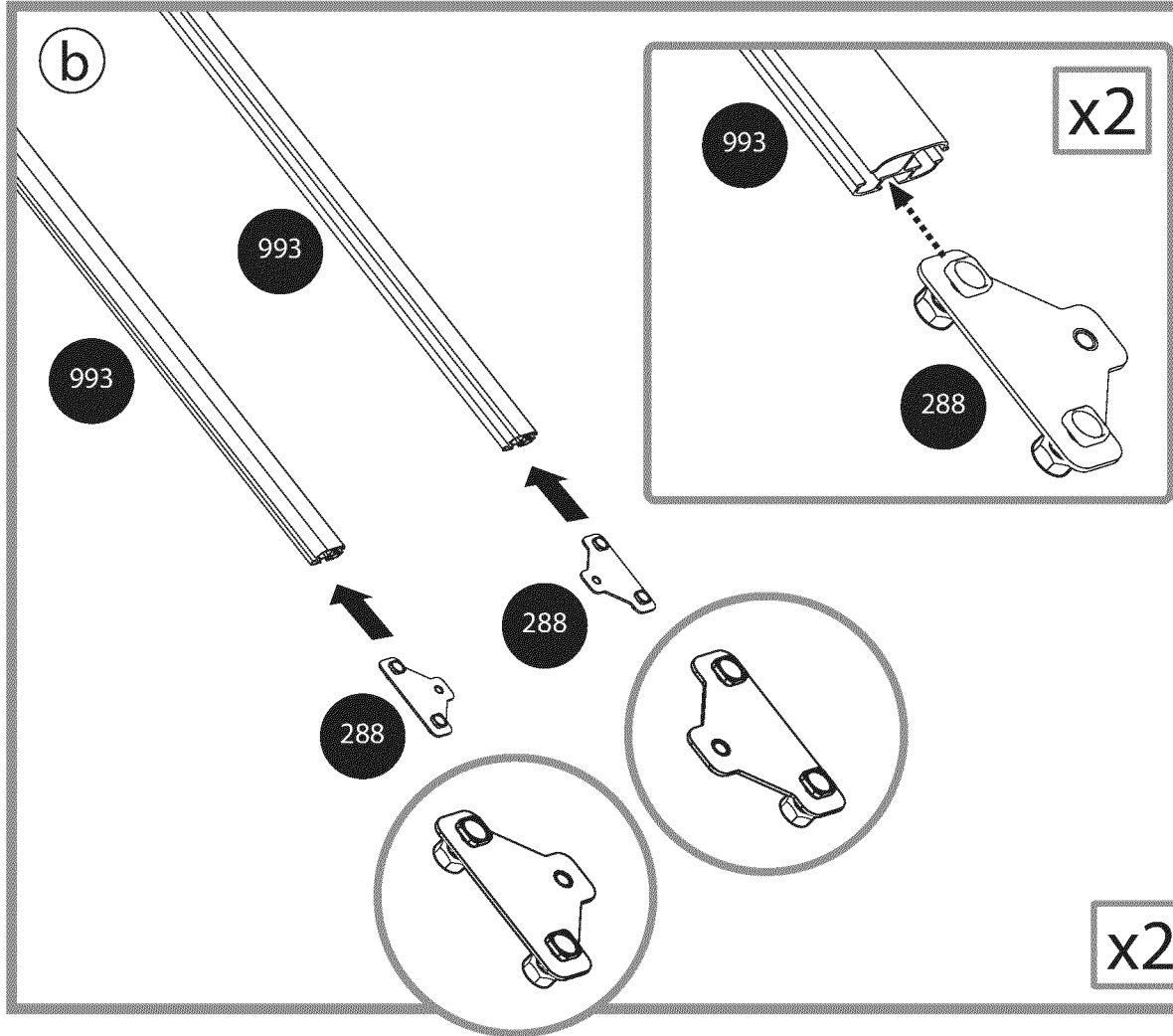

x2

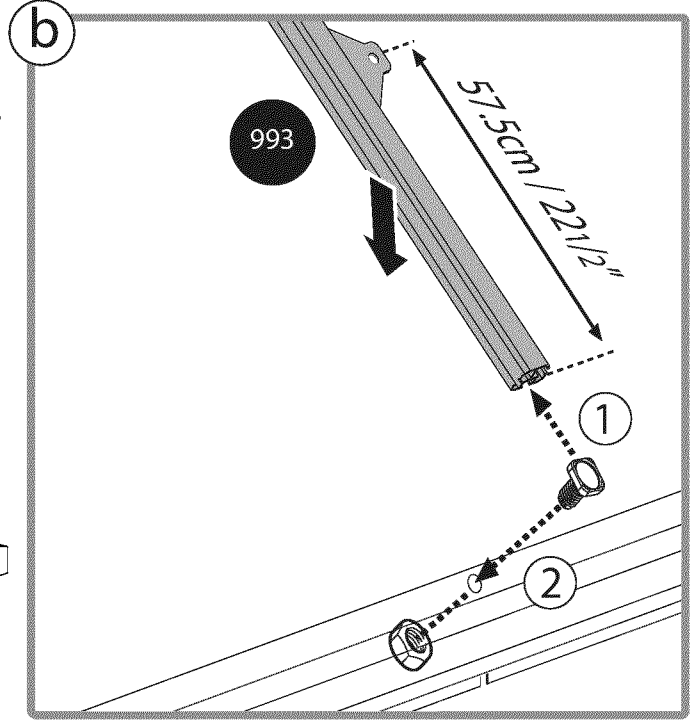
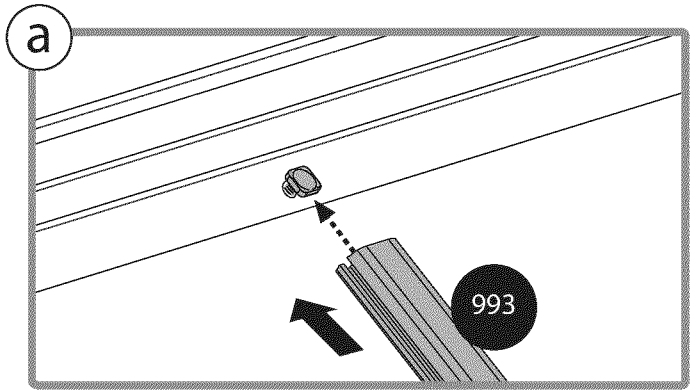
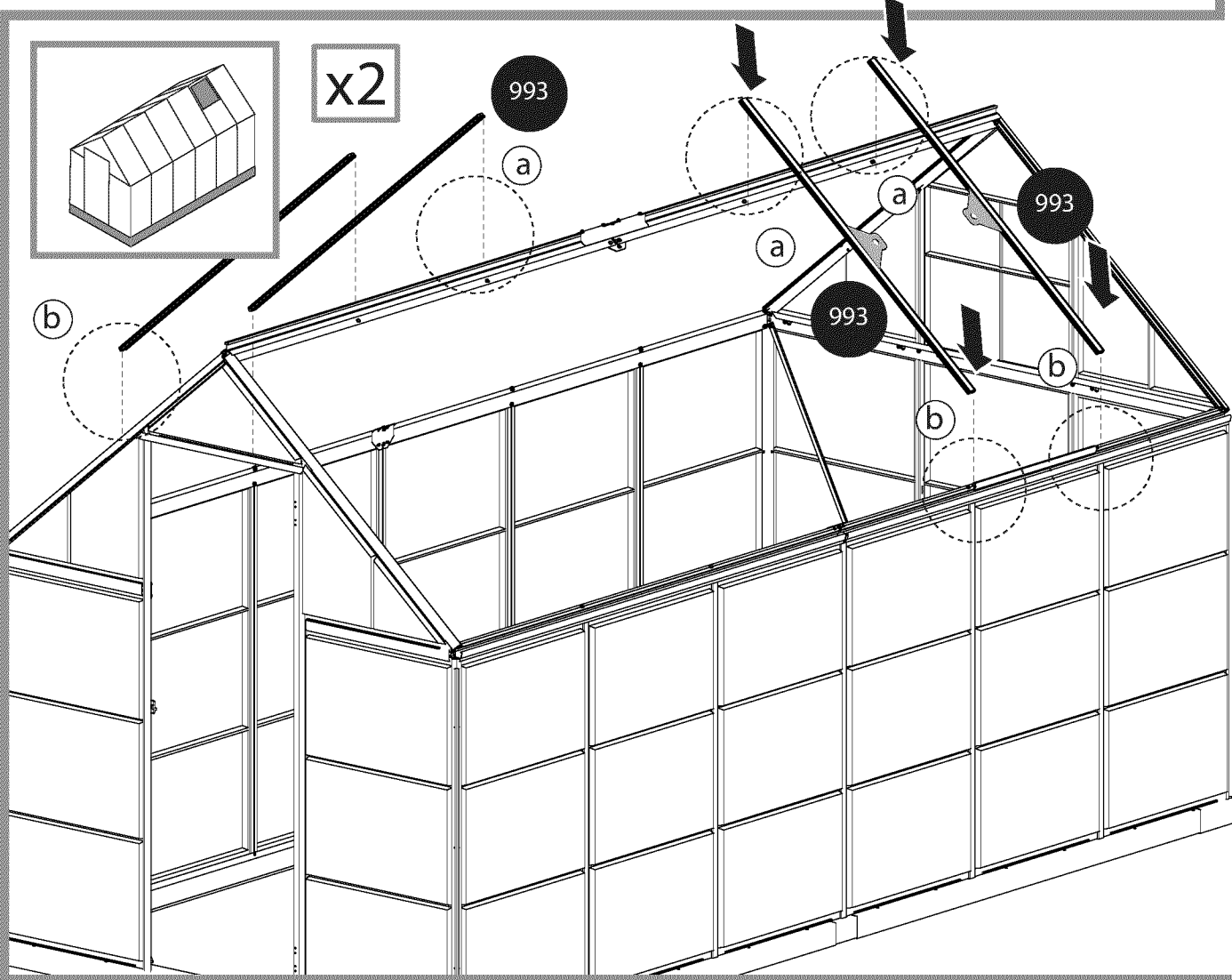
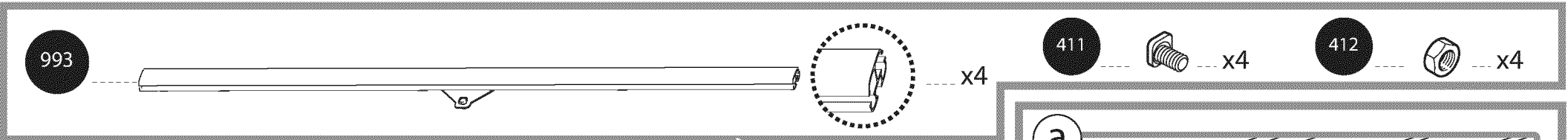
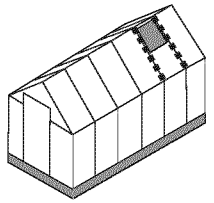

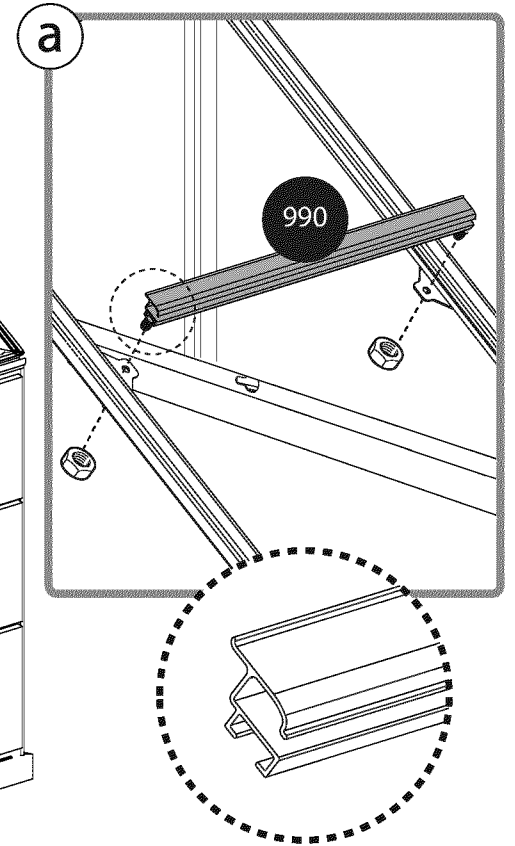
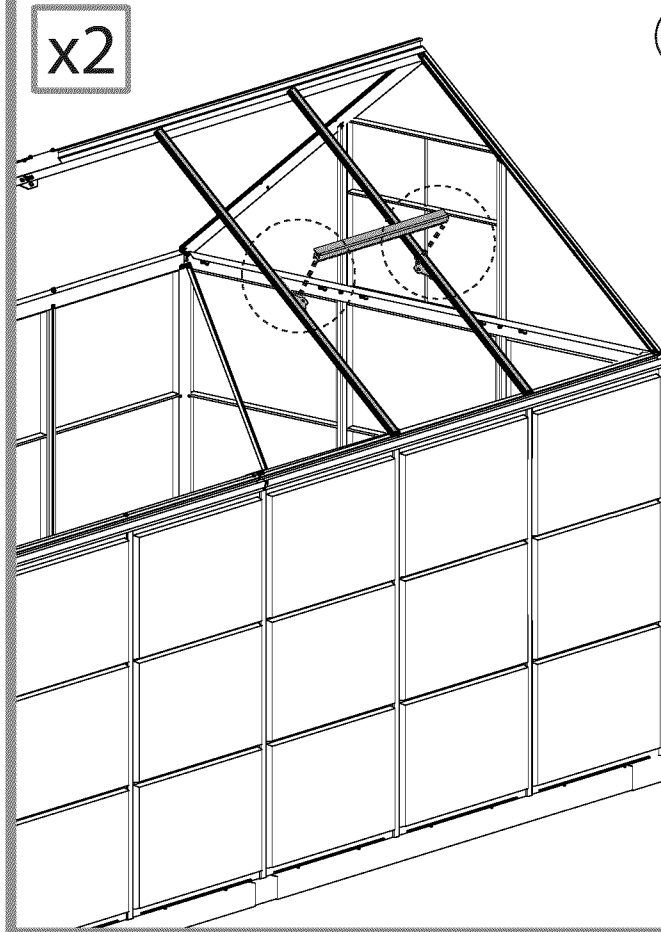
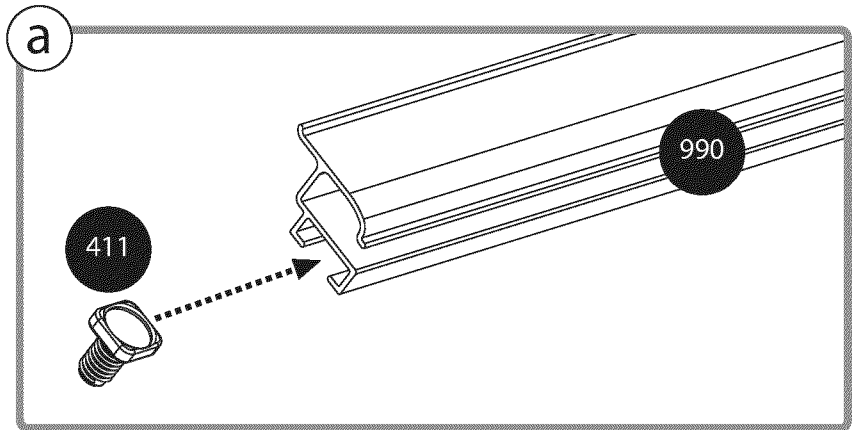
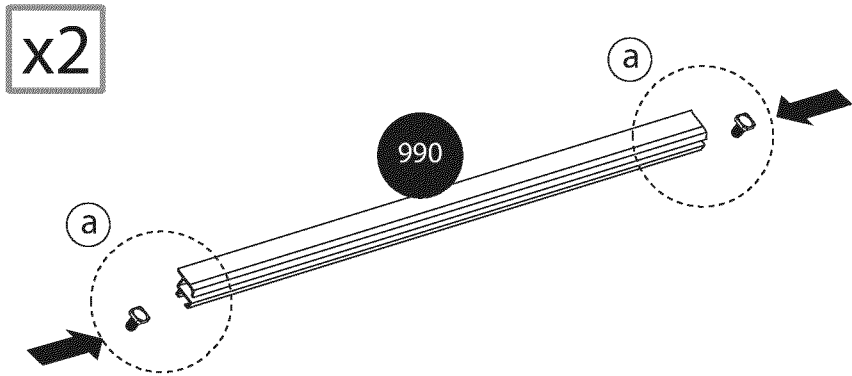
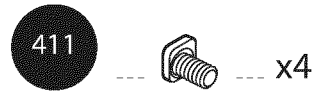
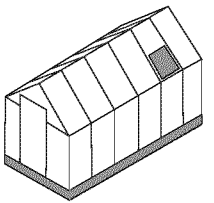

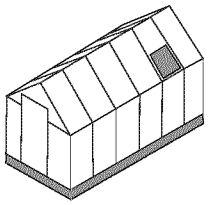

586

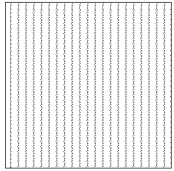

x2

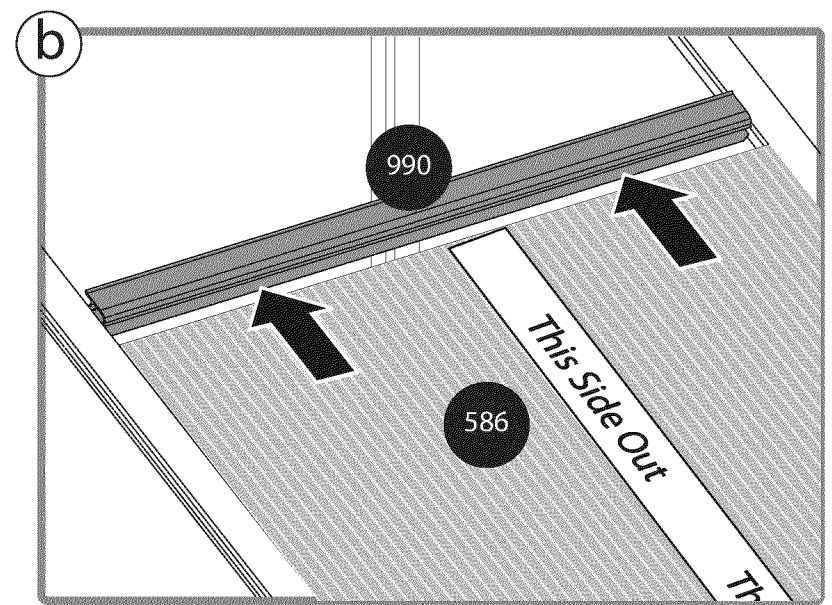
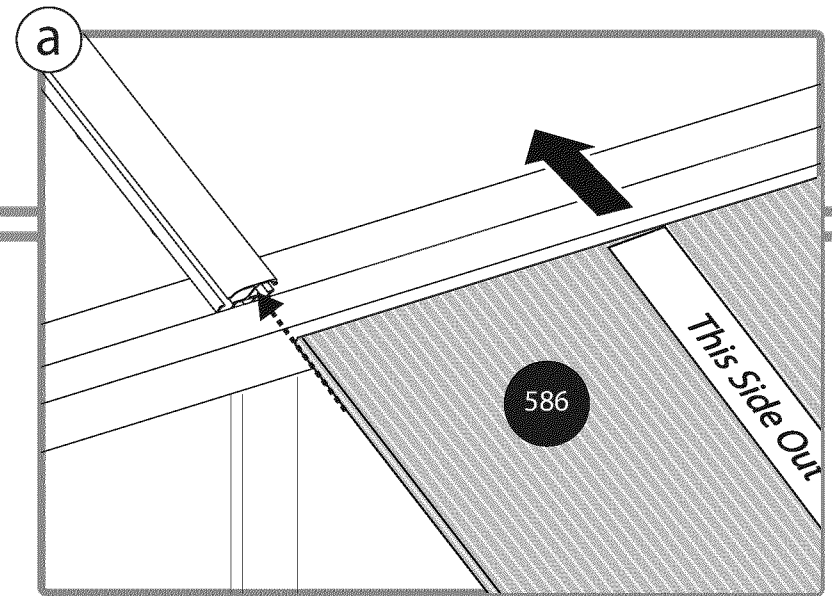
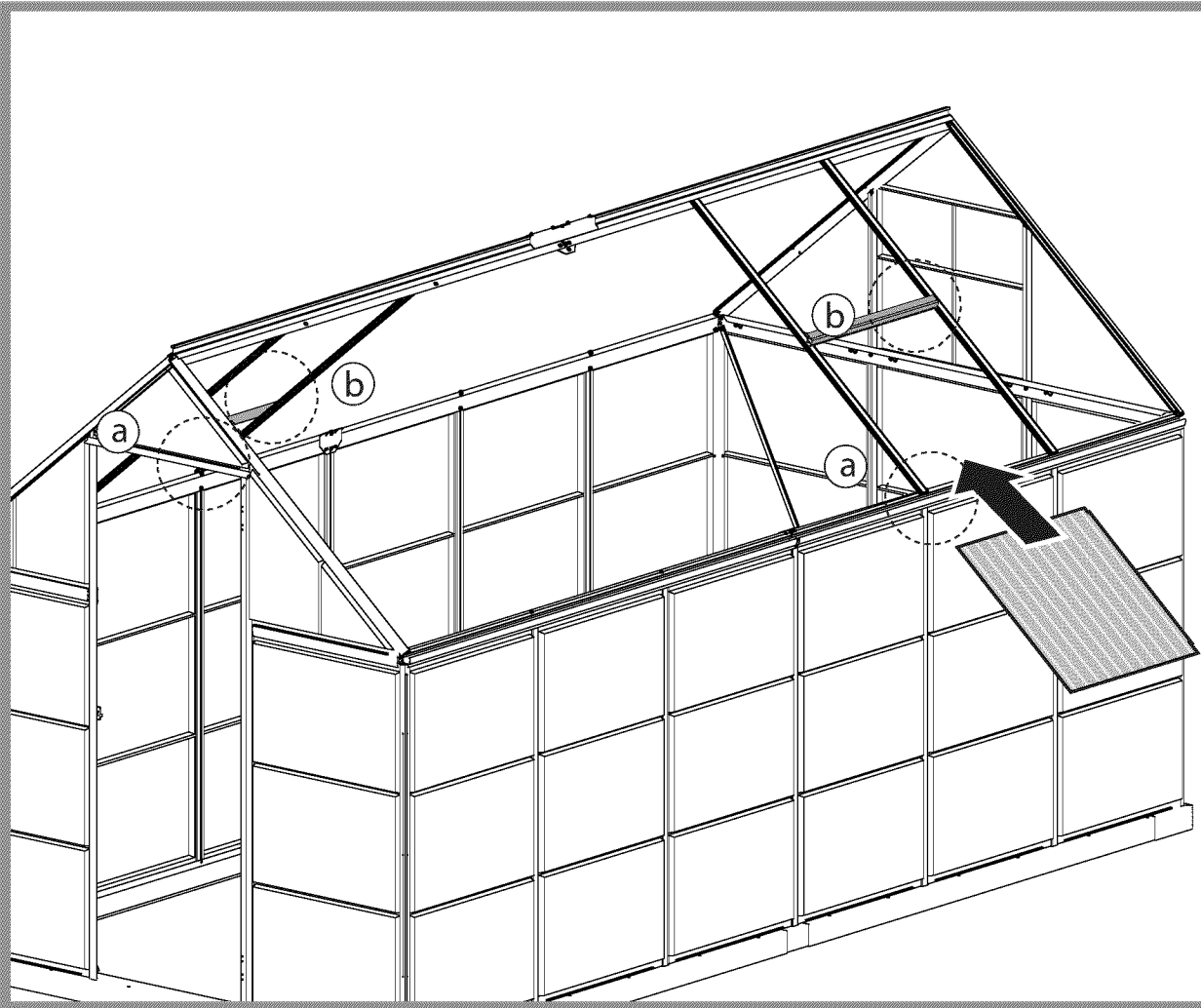

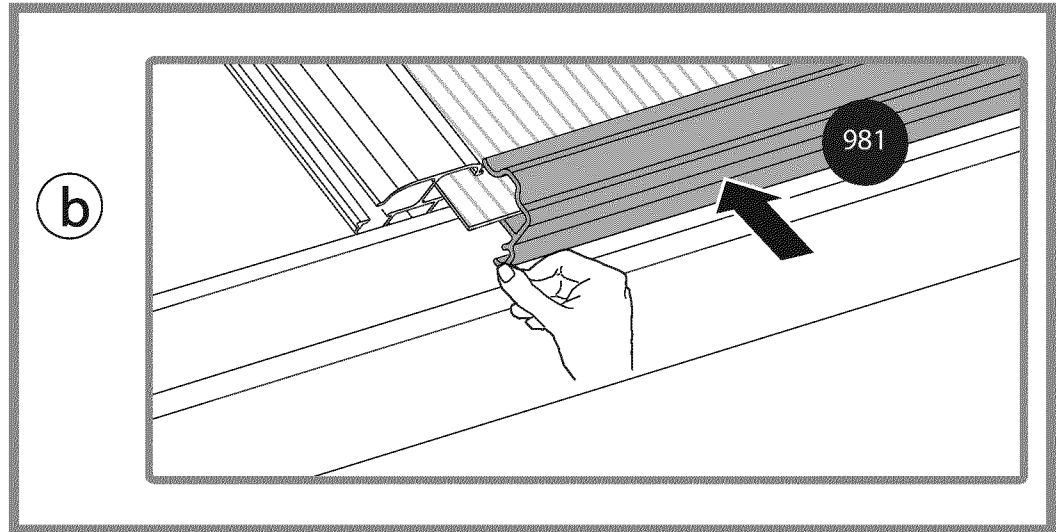
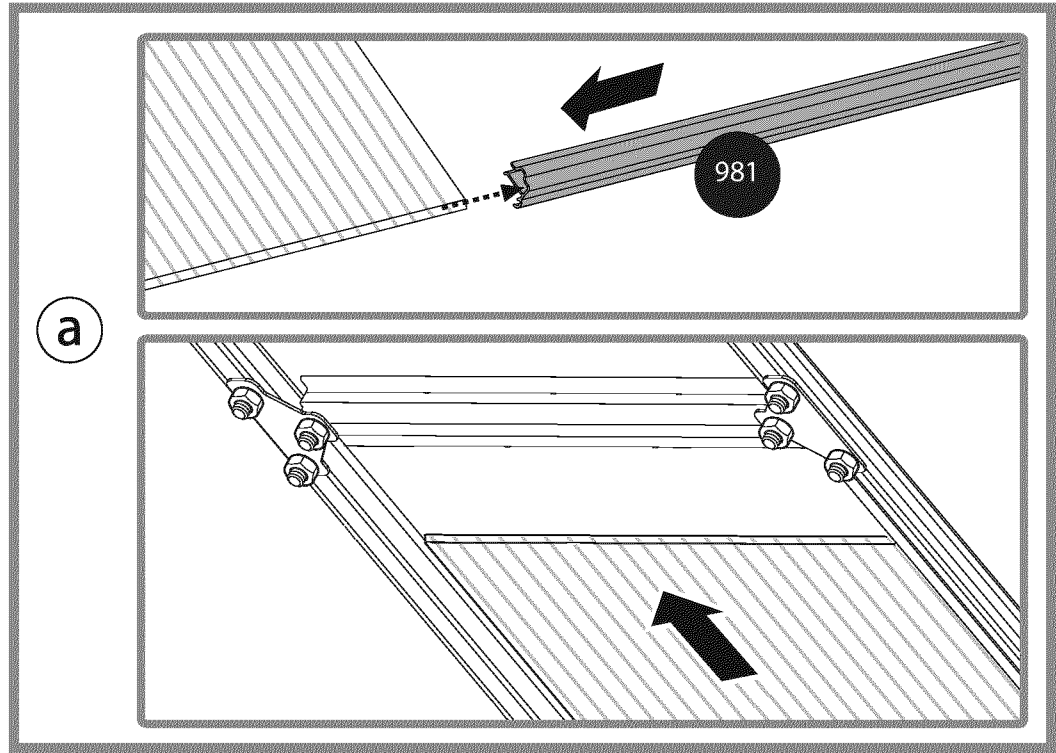
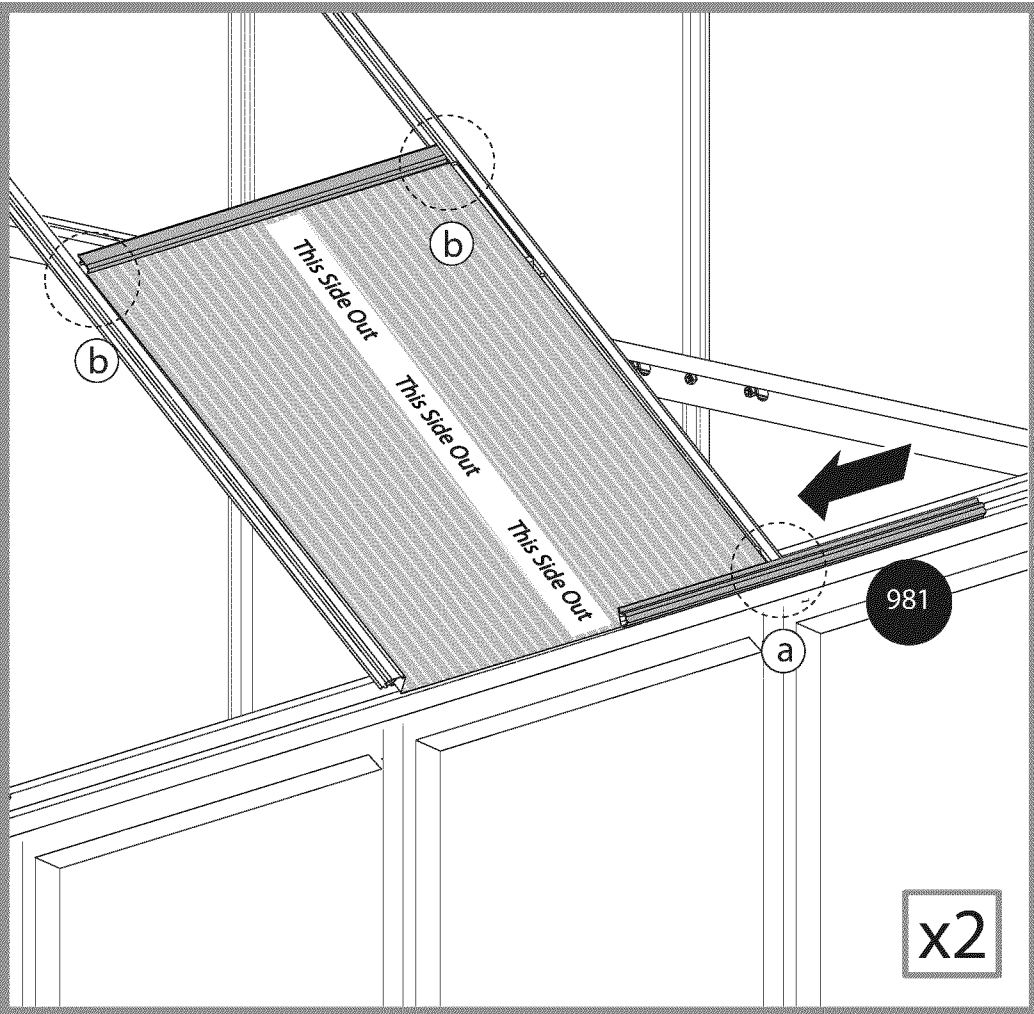
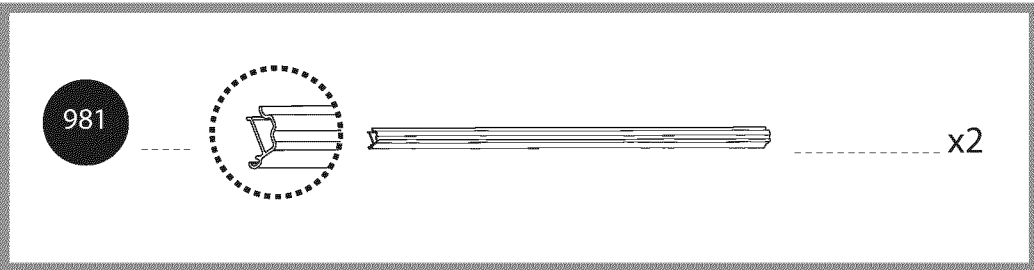
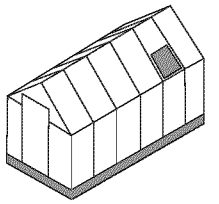

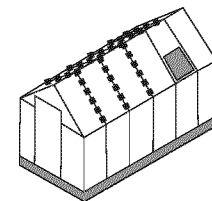

993

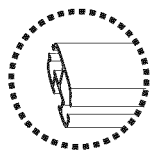

x6

411



x6

412



x6

993

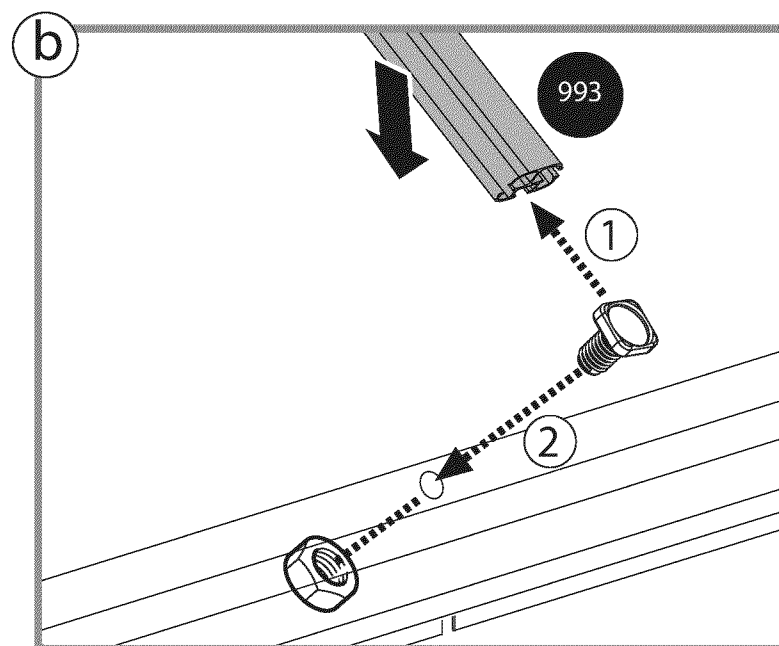
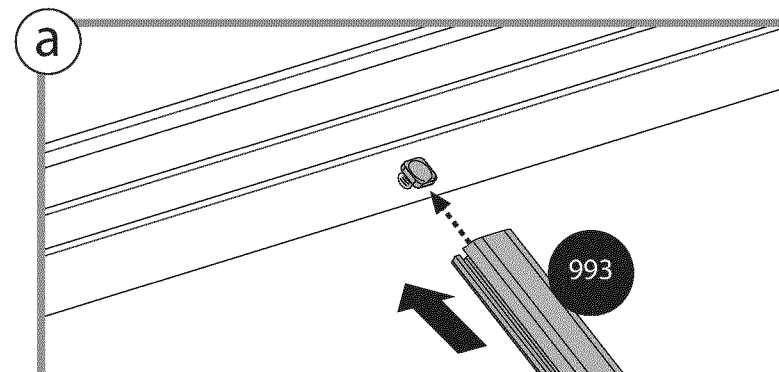
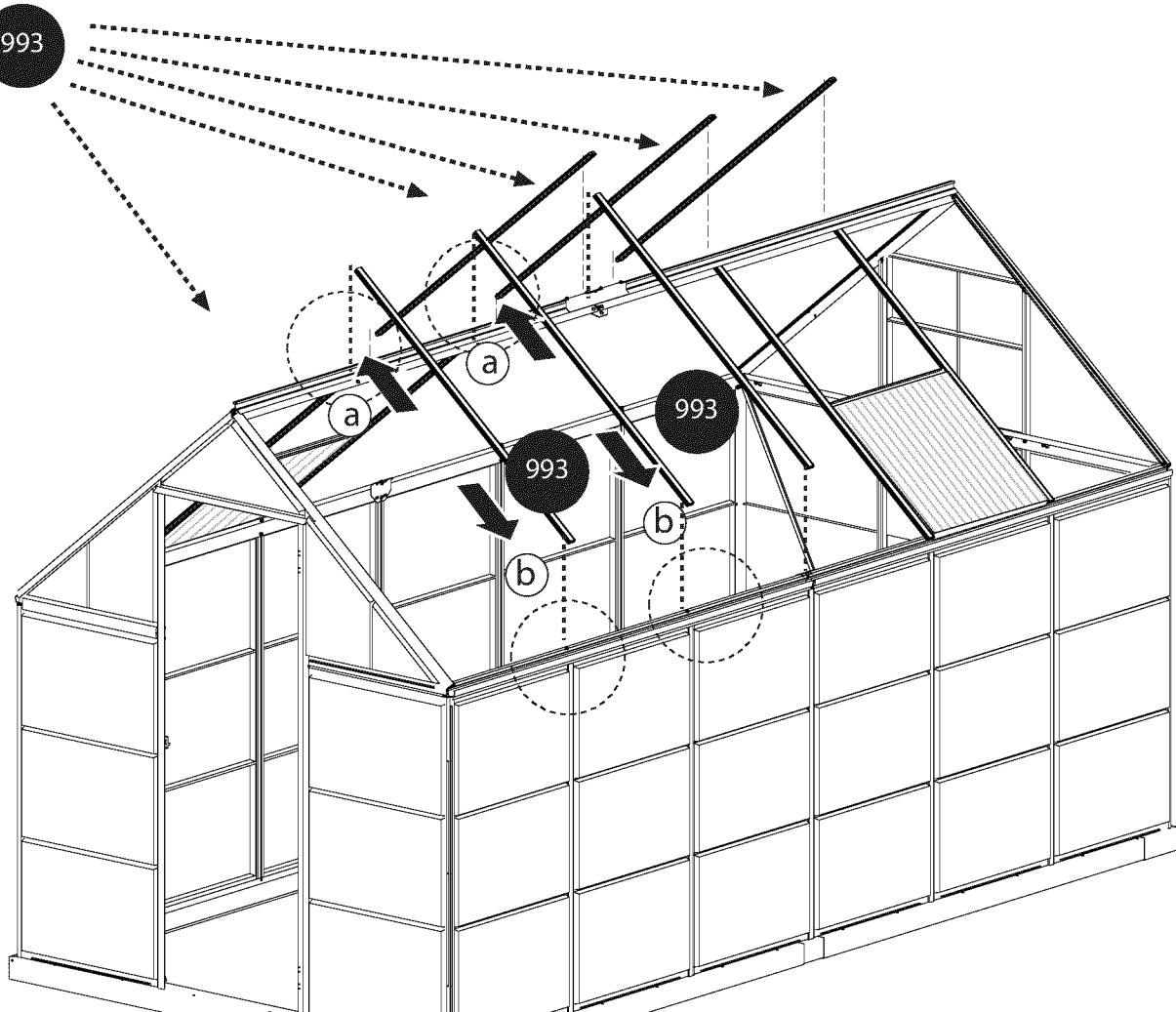

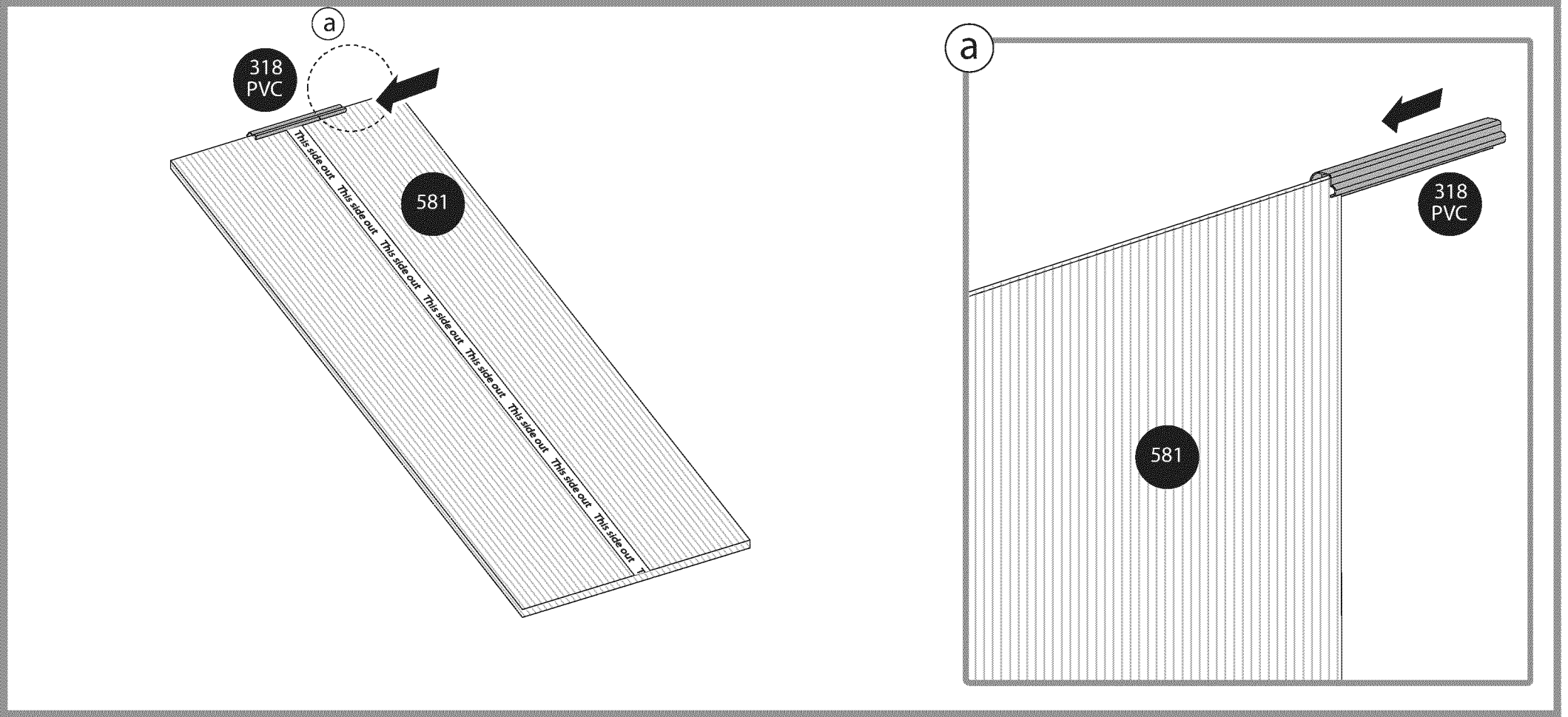
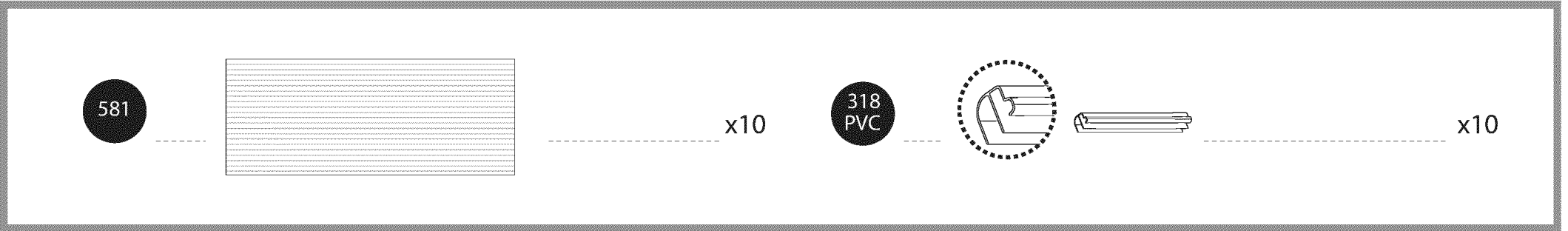
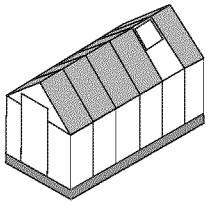

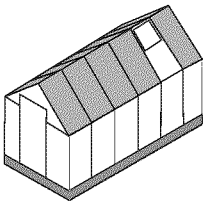

581 + 318 PVC x1

981 x1

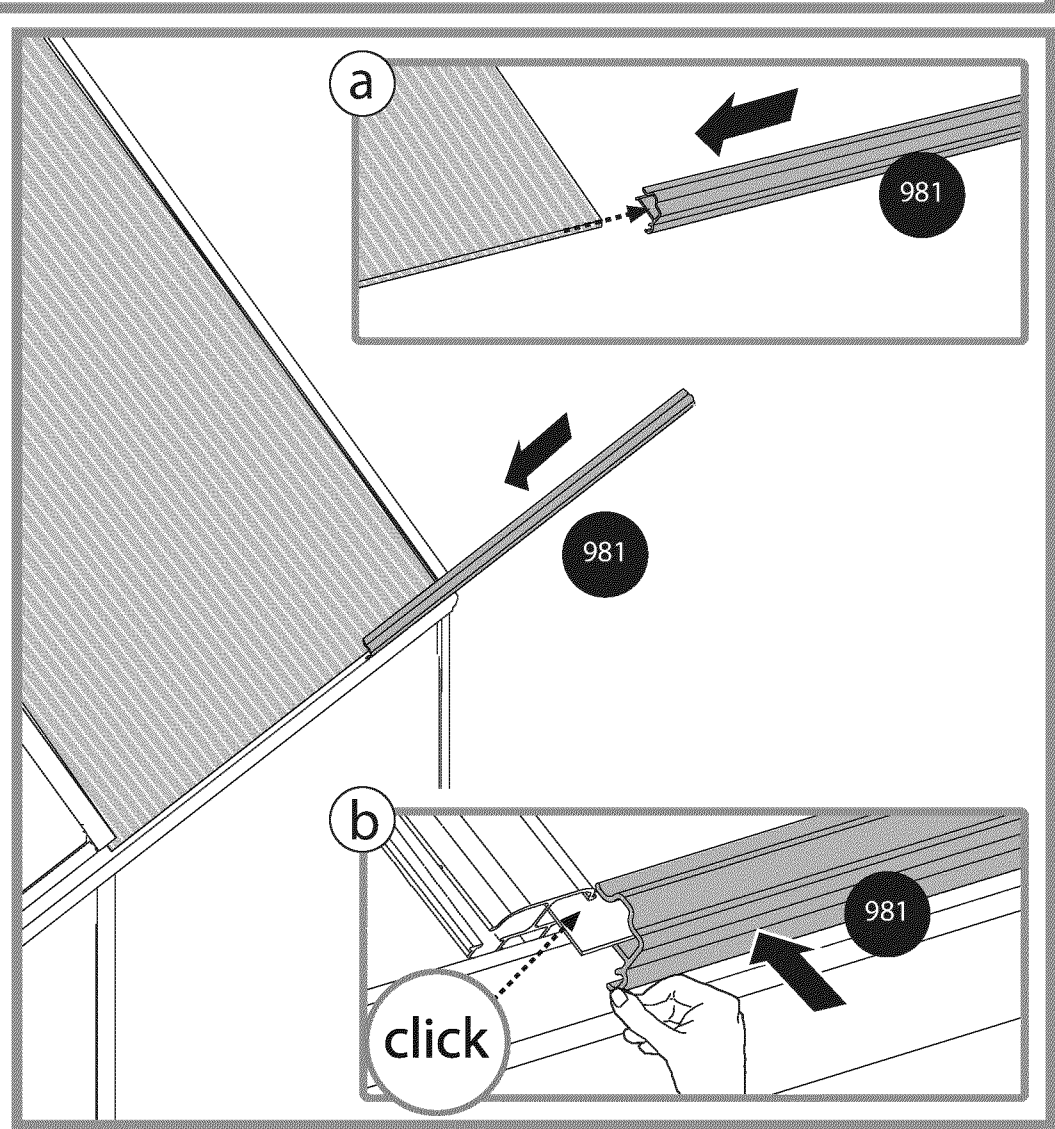
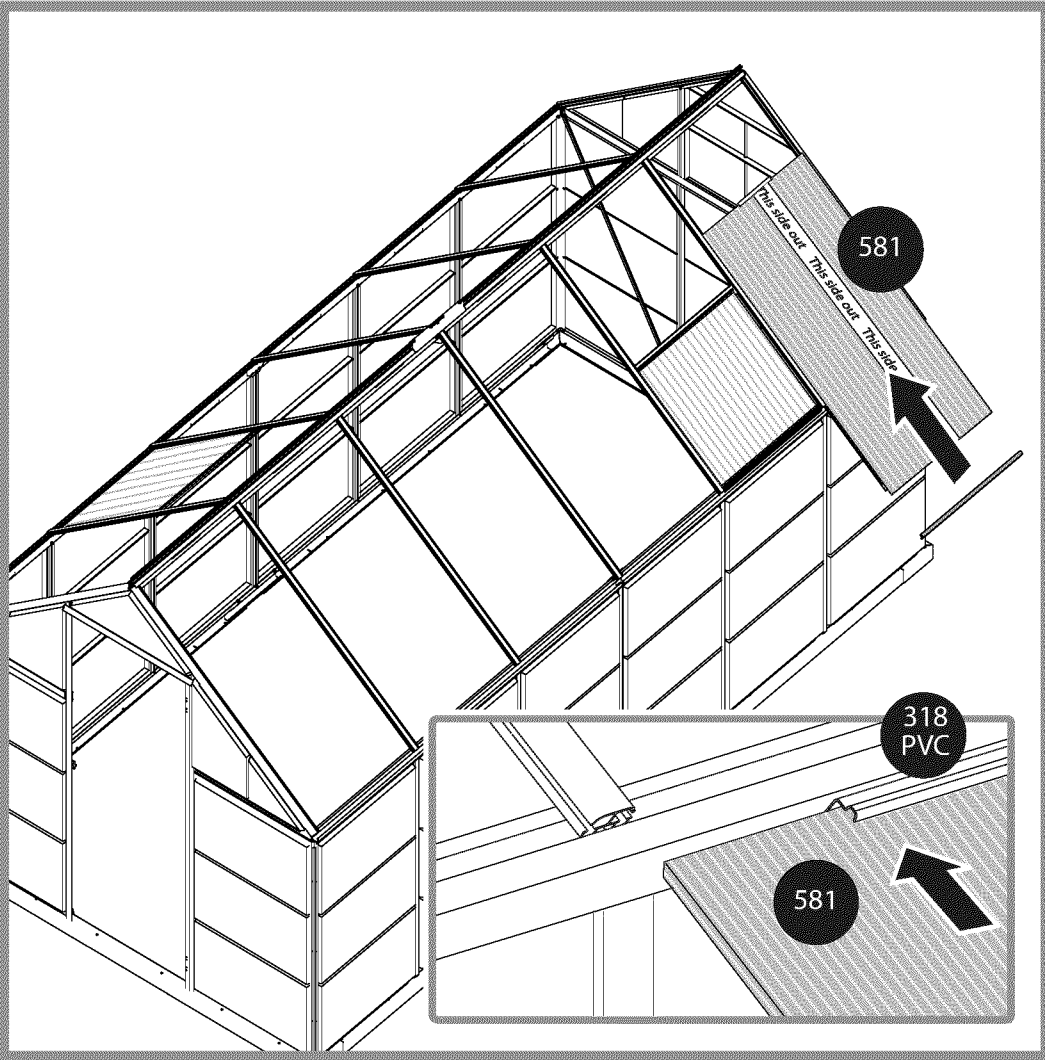

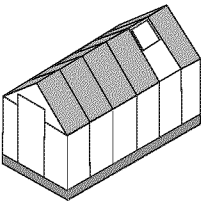

581 + 318 PVC



x9

981

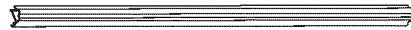
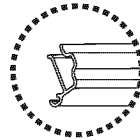

x9

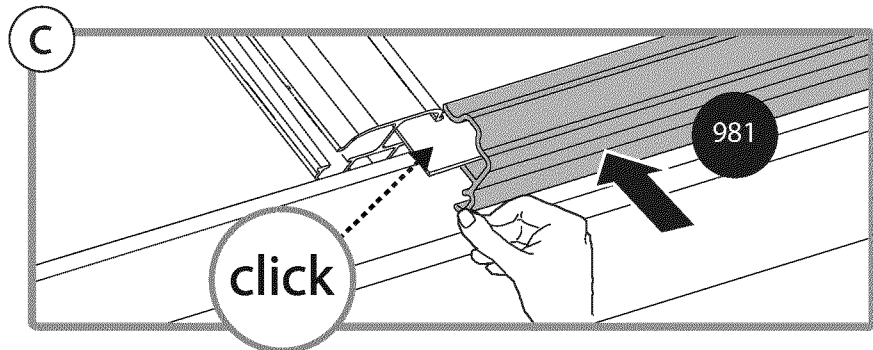
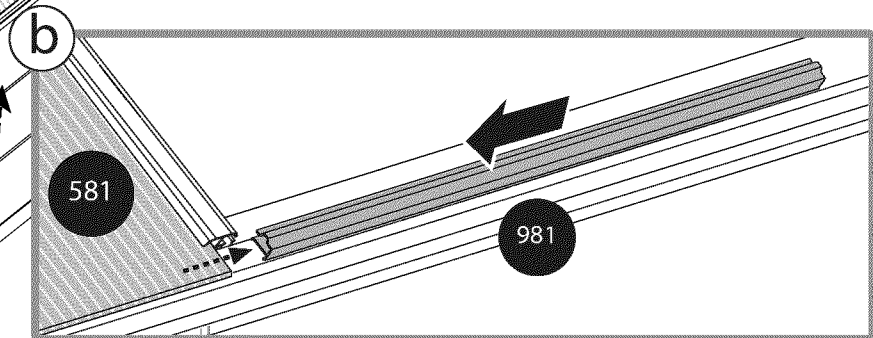
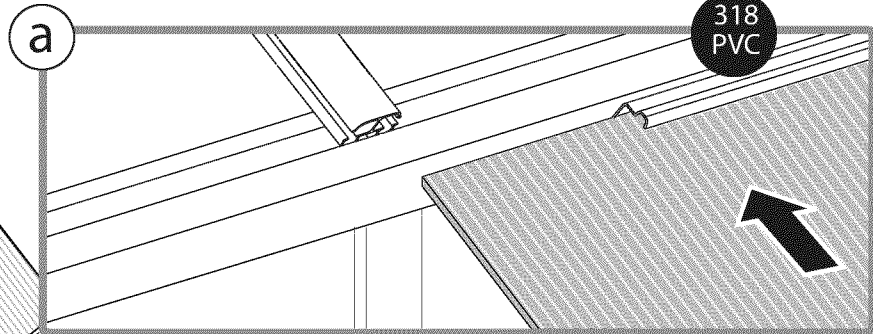
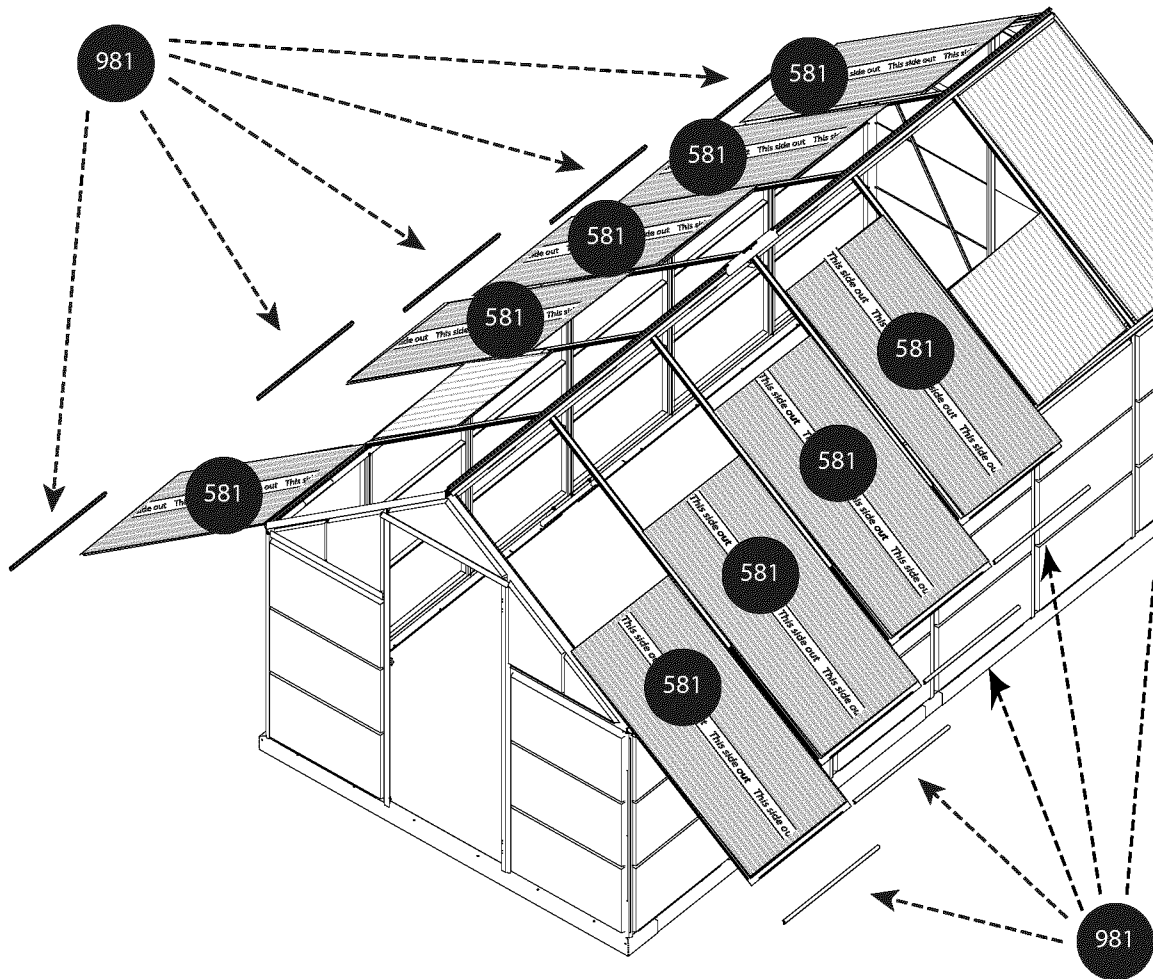

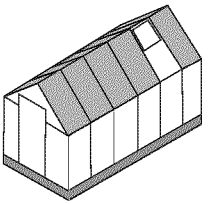

329

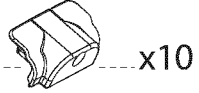

4043

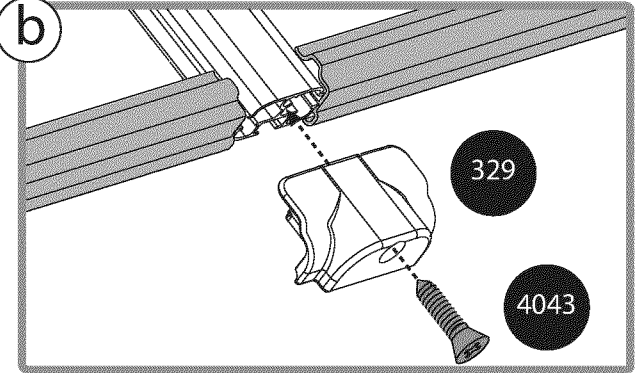
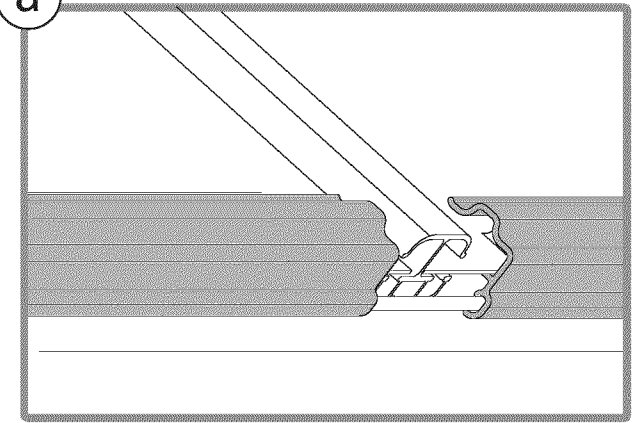
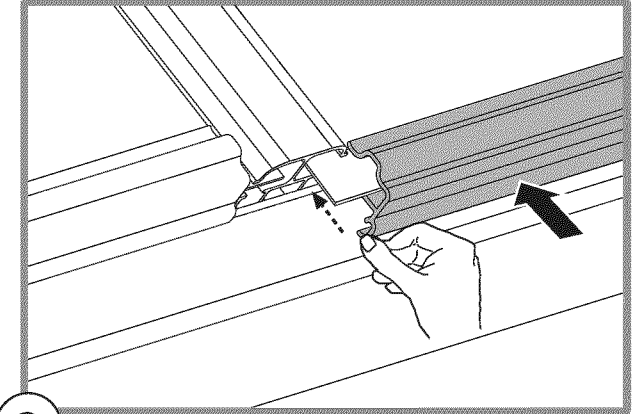
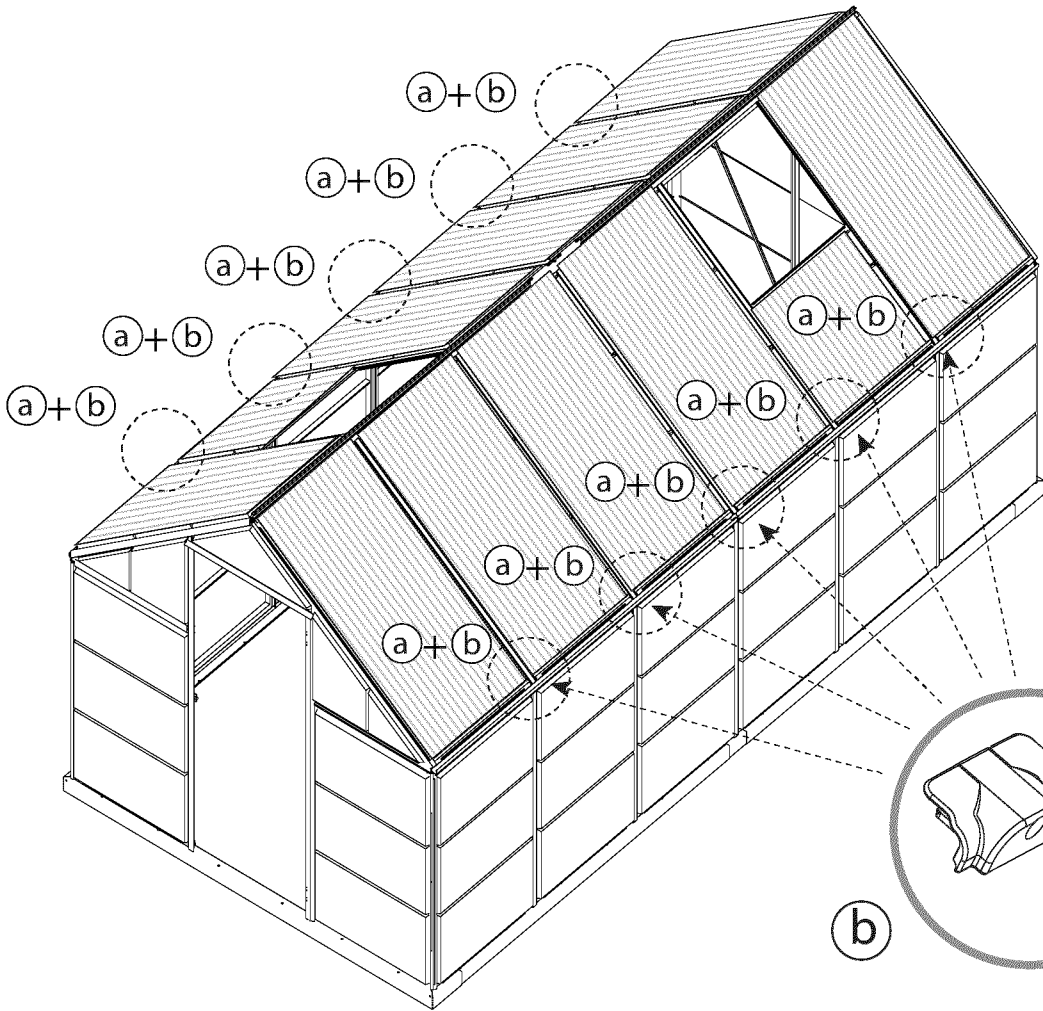

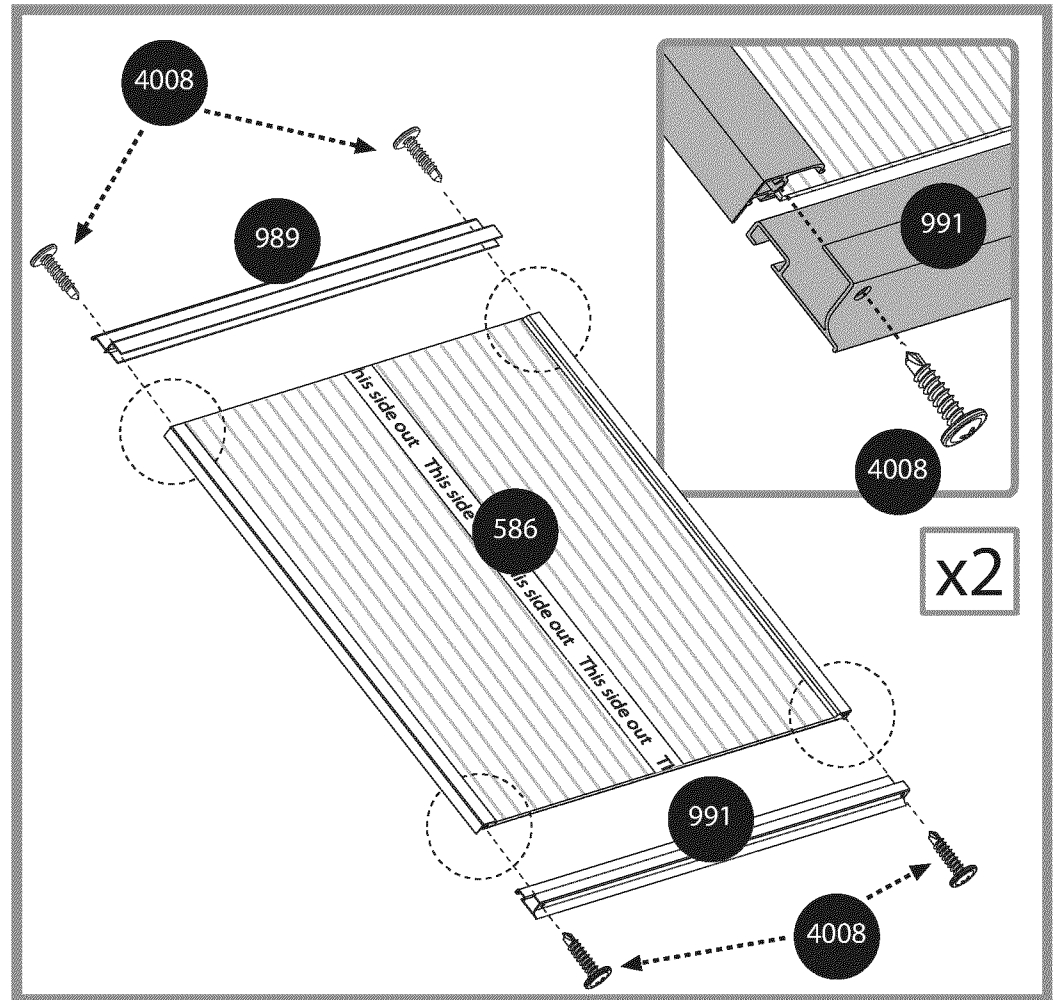
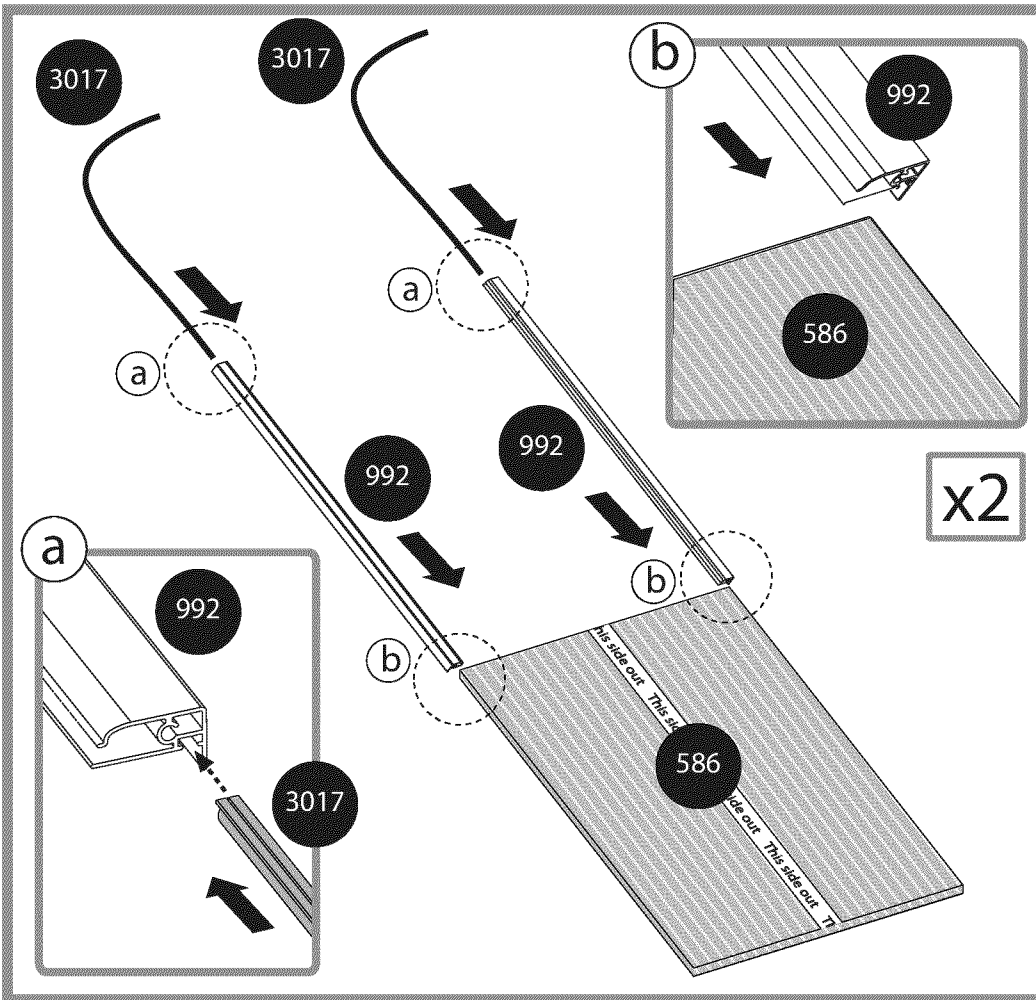
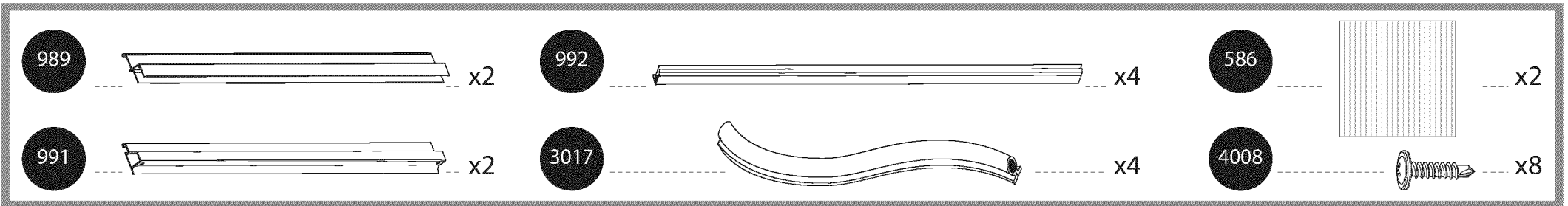
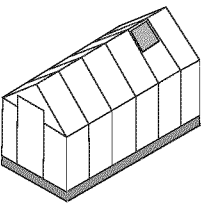

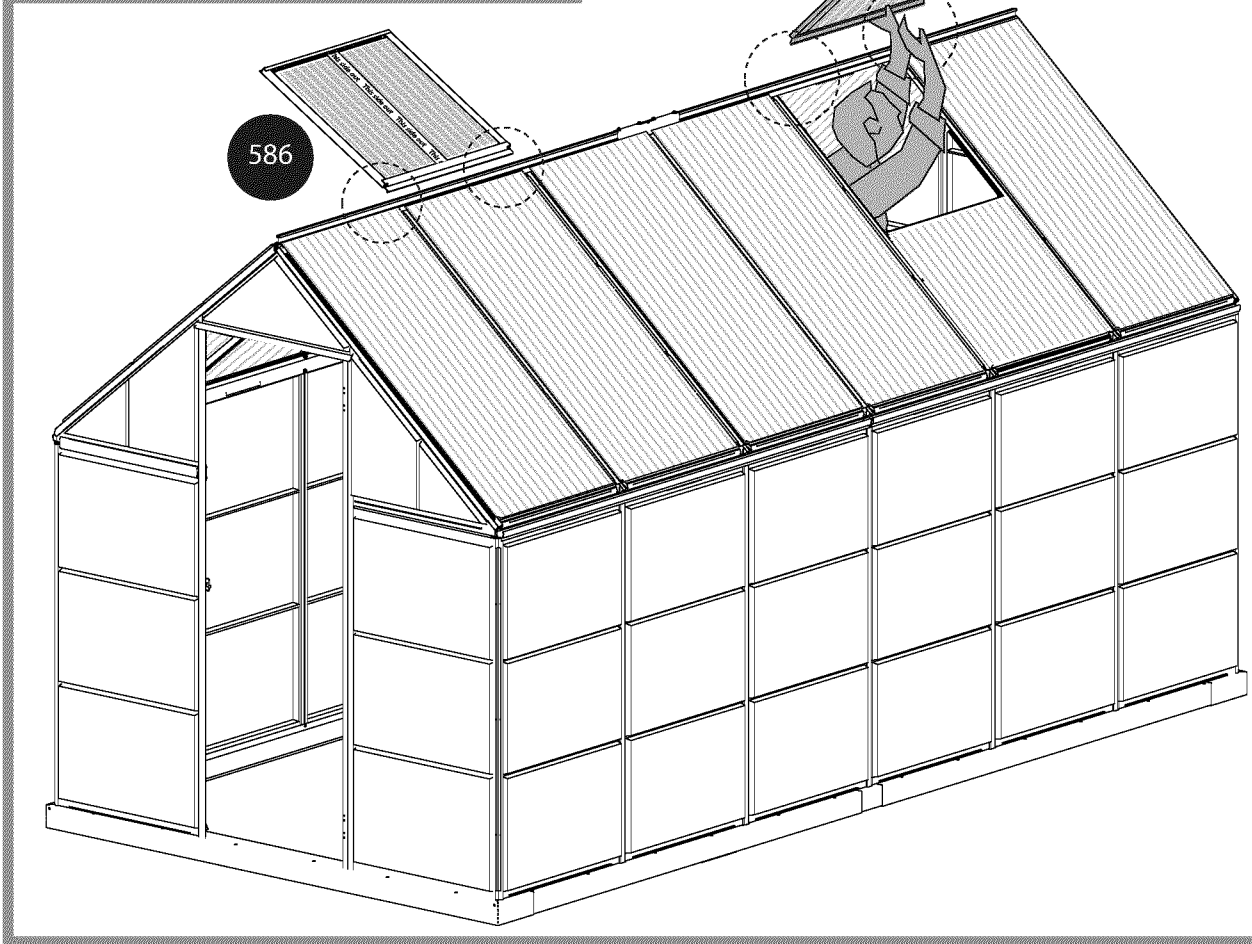
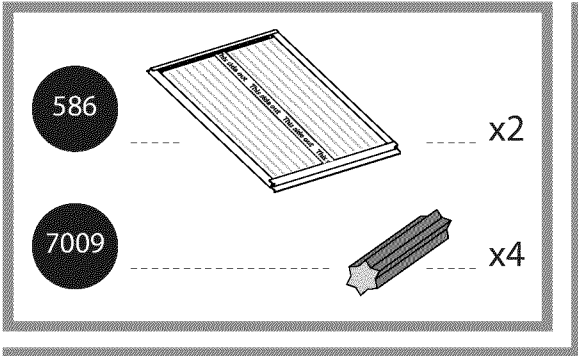
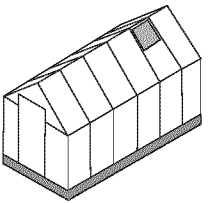

x2

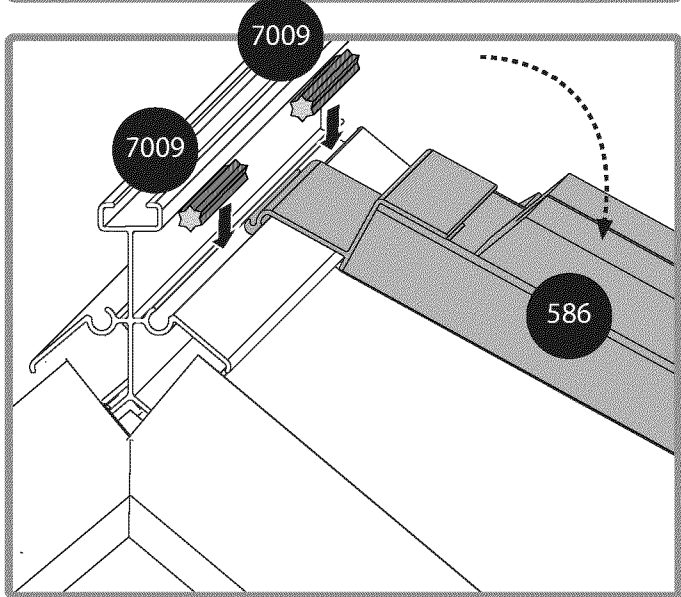
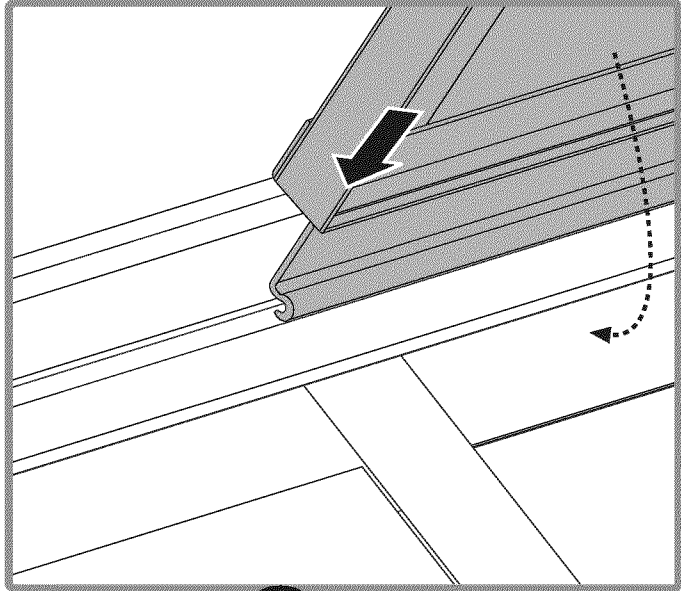

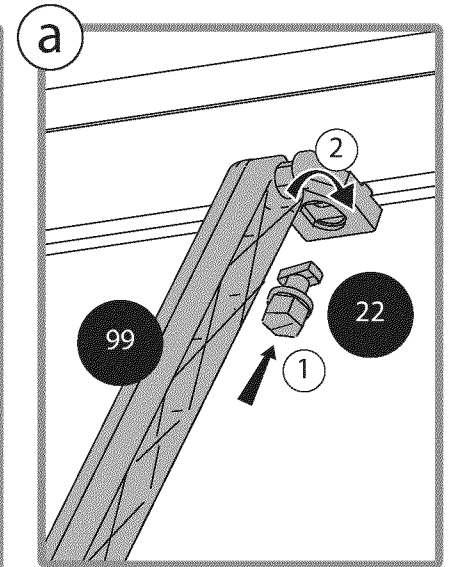
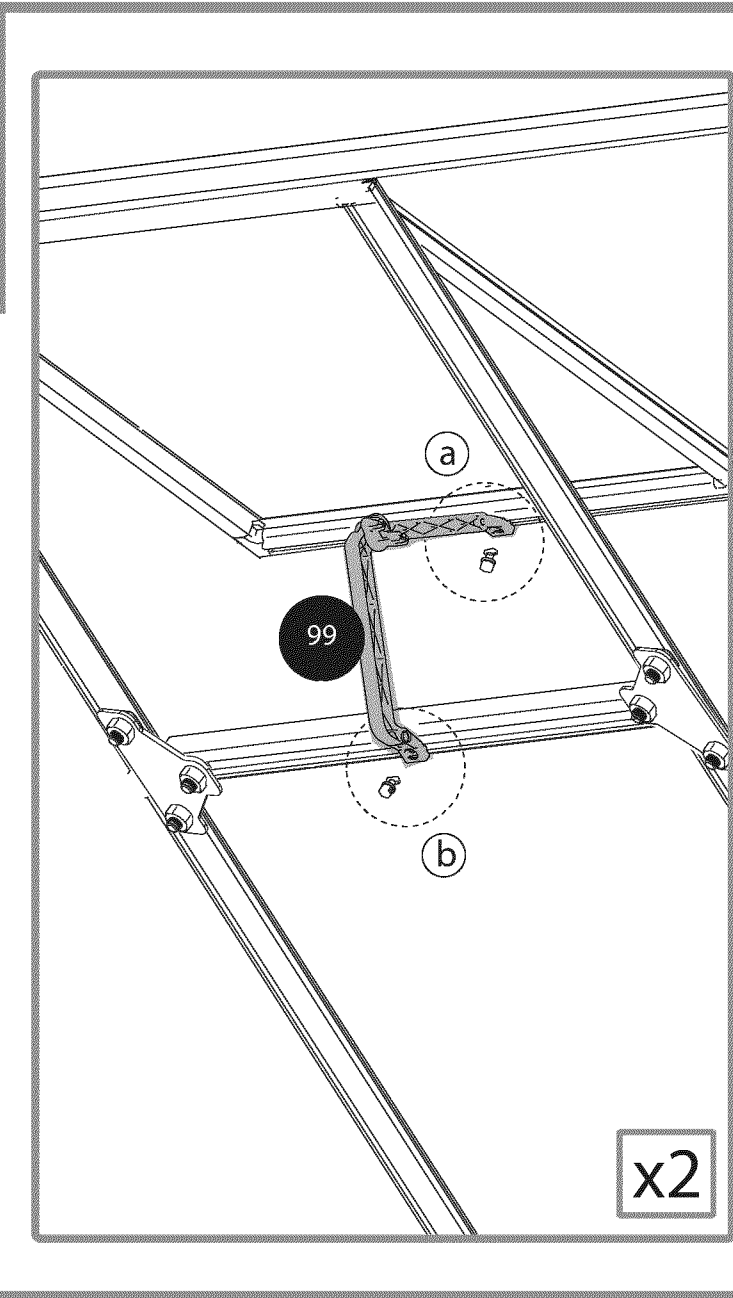
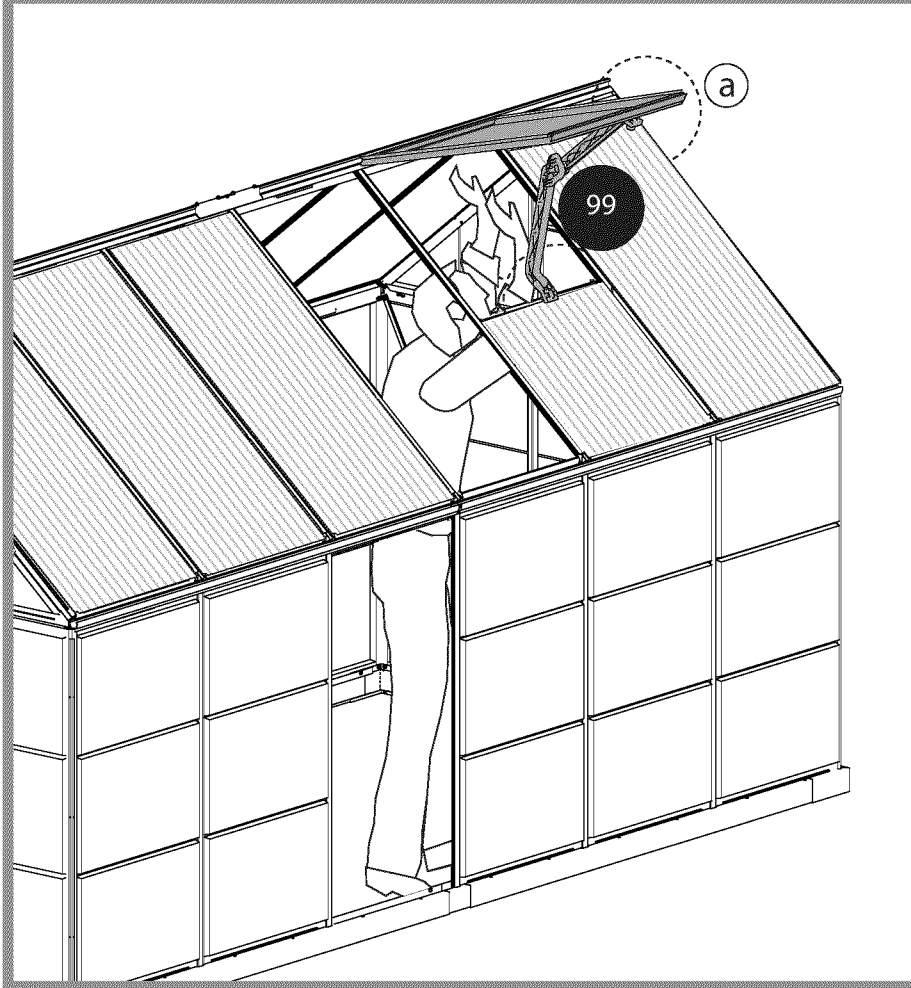
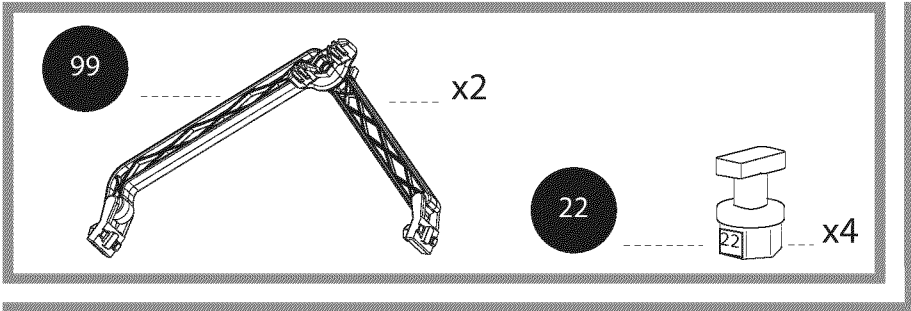
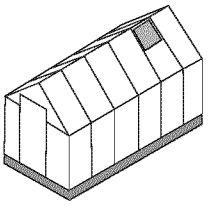

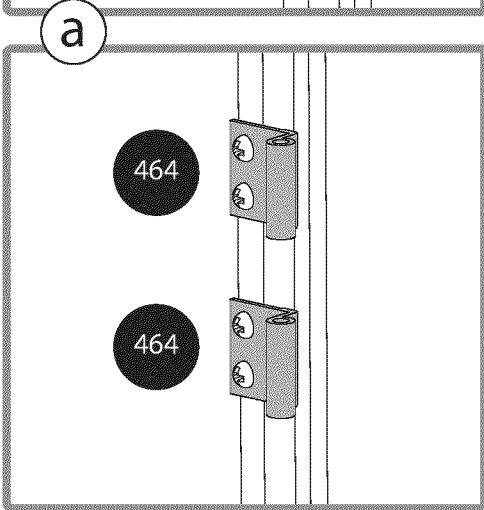
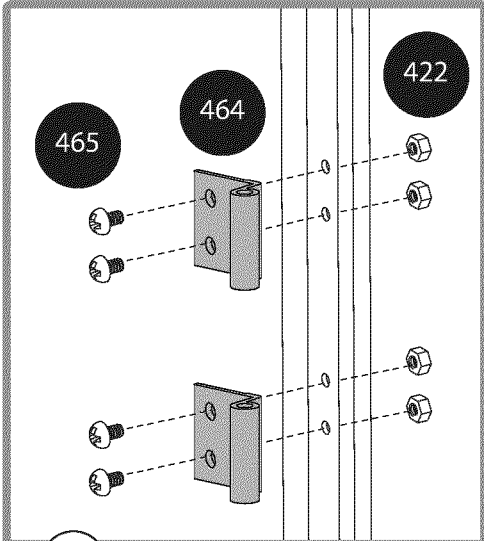
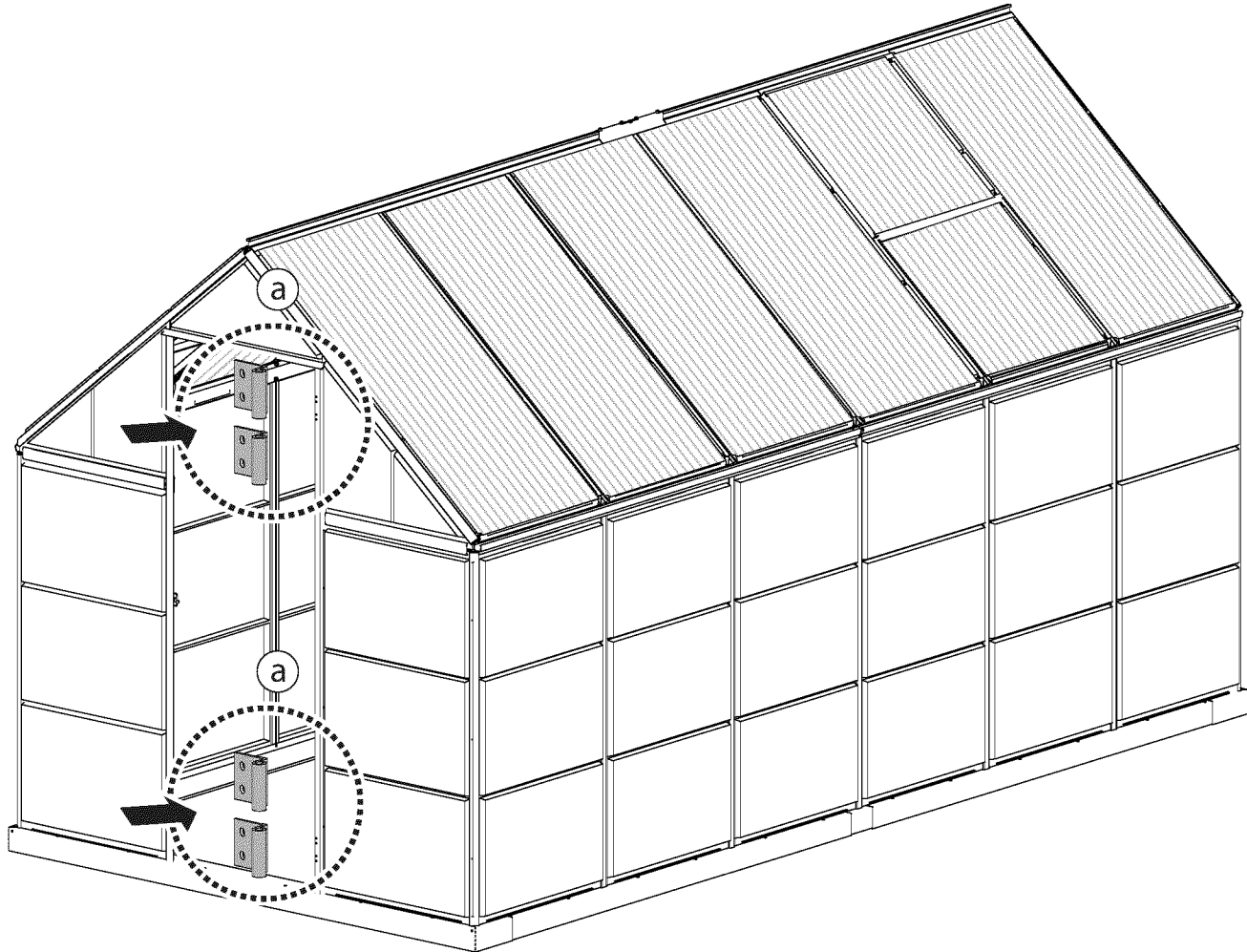
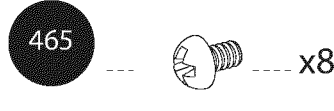
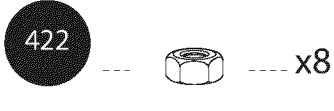
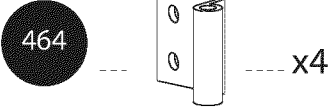
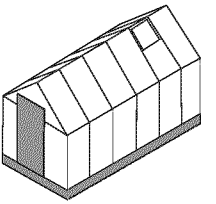

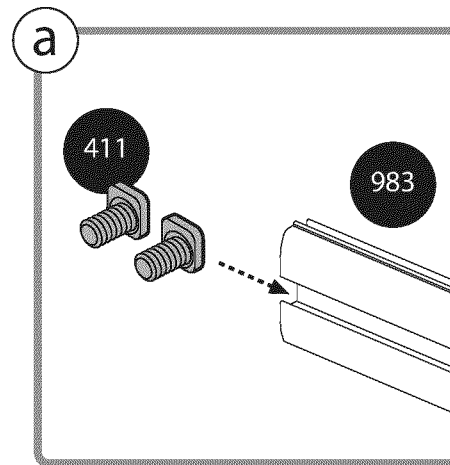
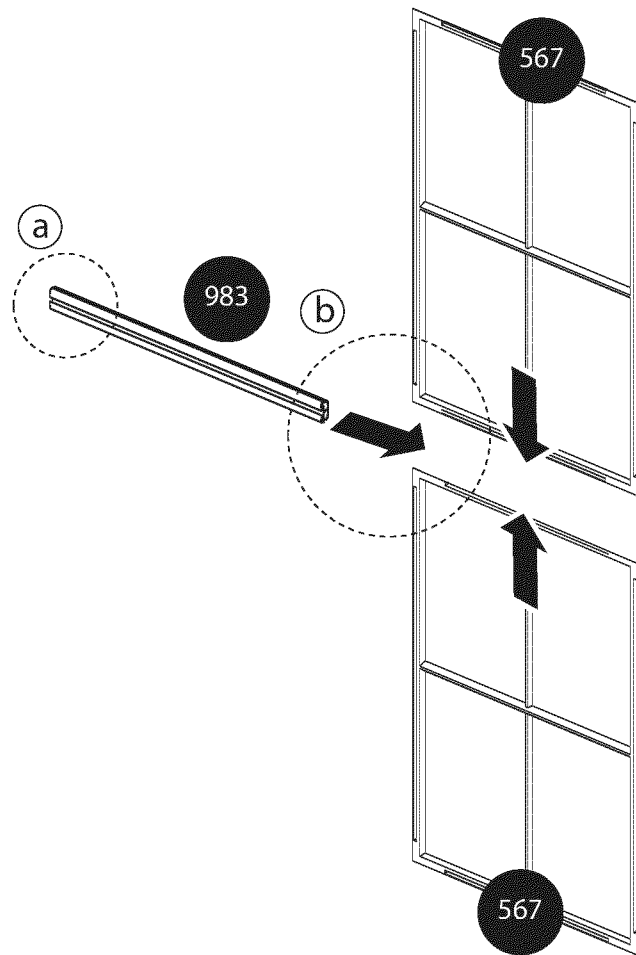
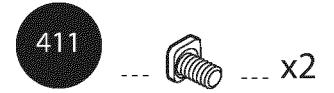
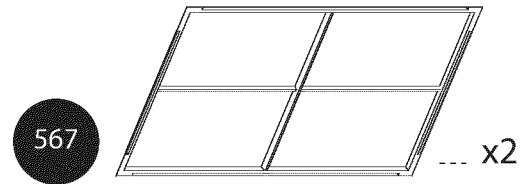
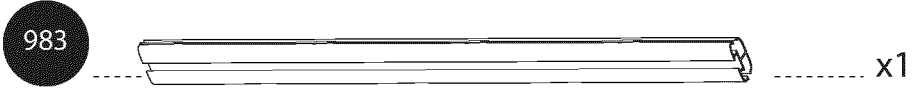
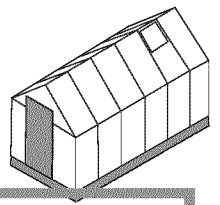

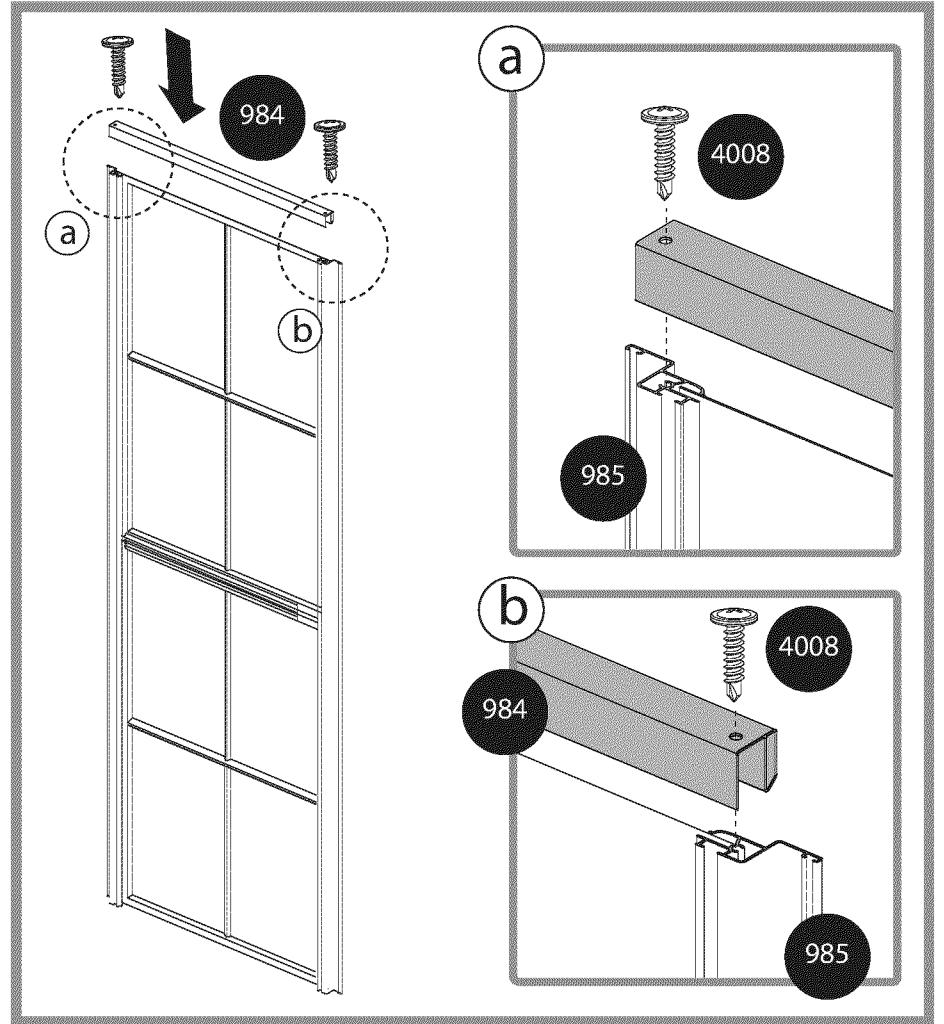
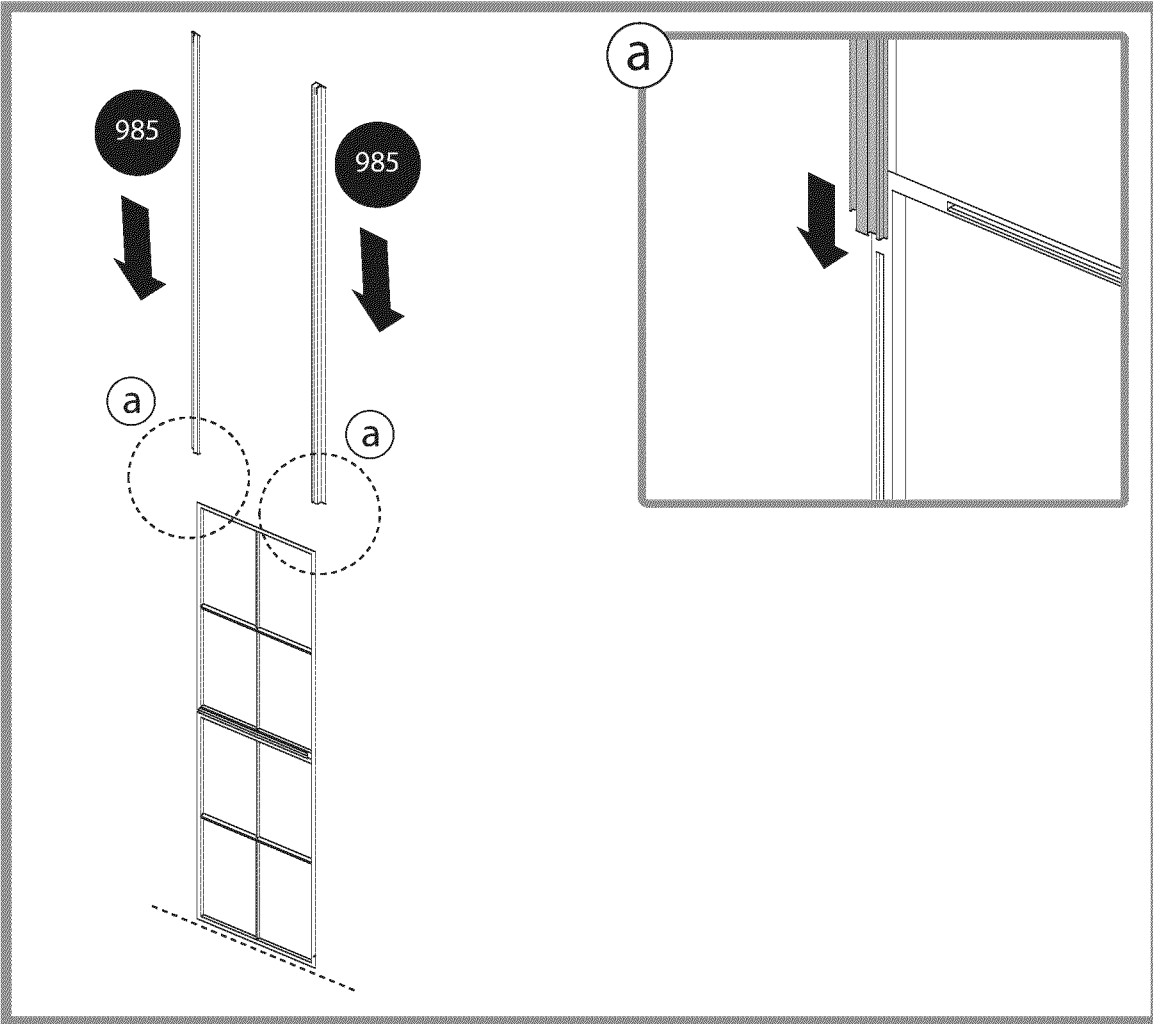
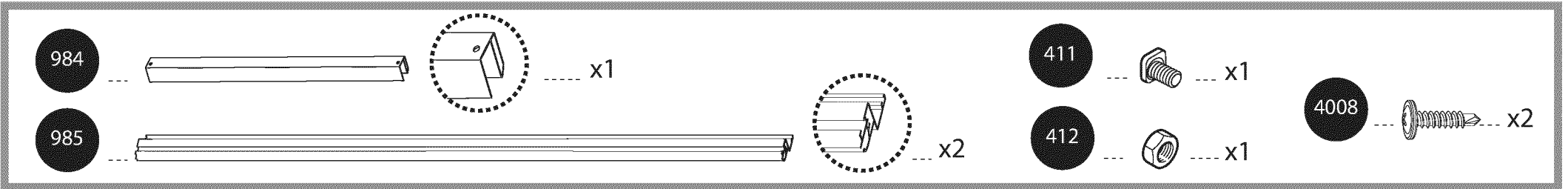
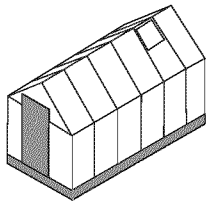

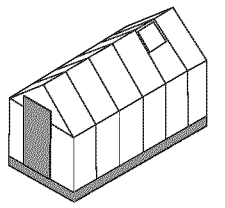

3016 x1

288 x1

412 x7

462 x2

411 x7

a

411 x6

b

411 x1

3016

412

462

288

412

412



462

462

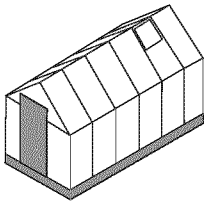
288

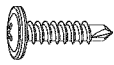

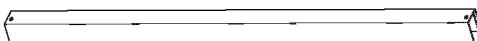
4008  x2

984   x1

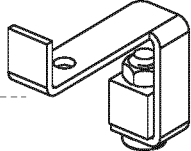
4037  x1

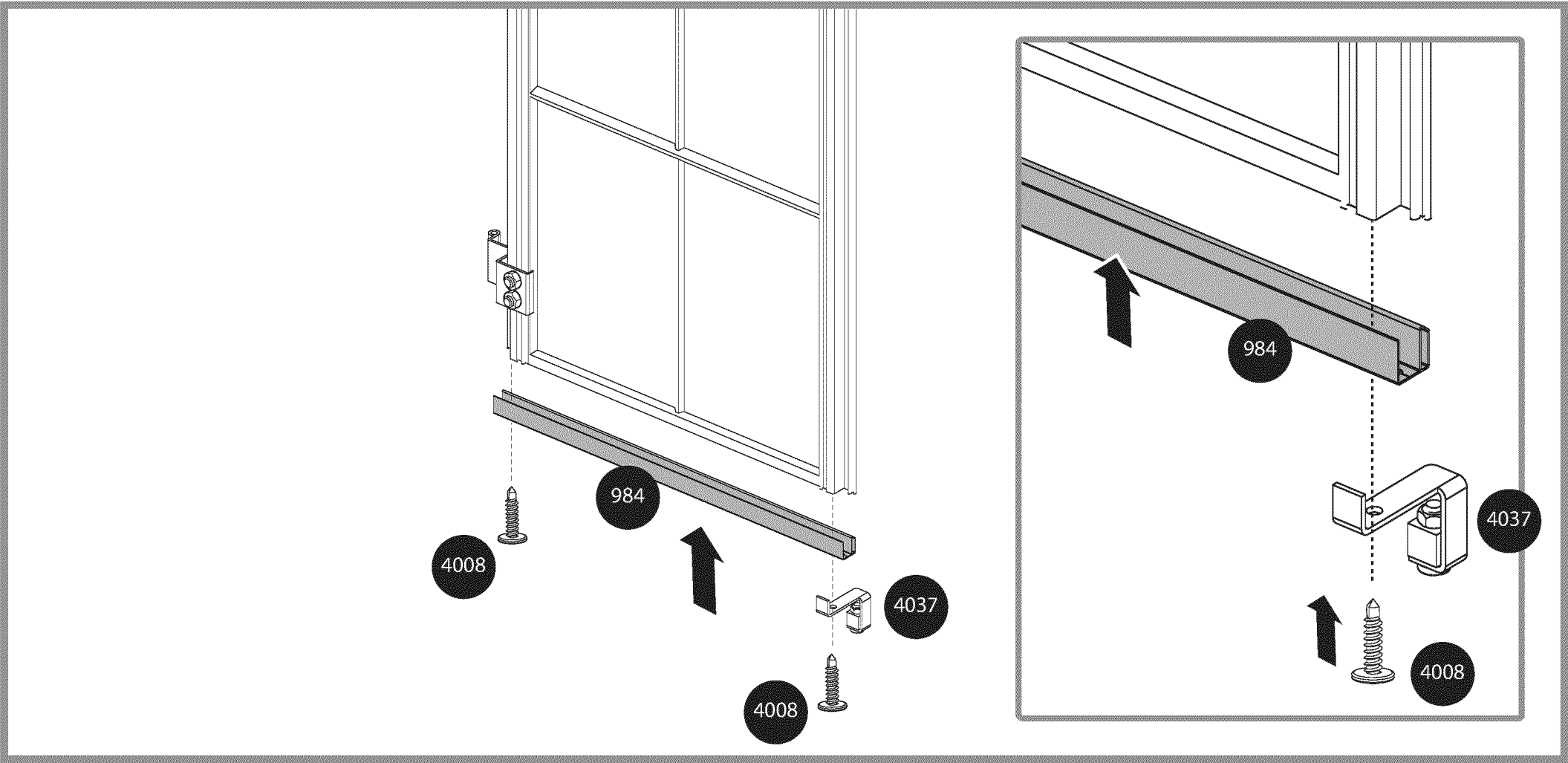

4008

984

4037

4008





4008

984

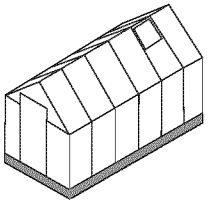
4037

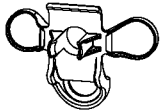
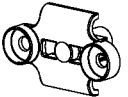
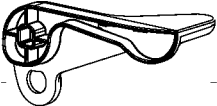
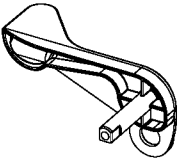
4008



- 7086  x1
- 7085  x1
- 7084  x1
- 7083  x1
- 7088  x1
M4 x 50mm
- 423  x1
- 412  x2

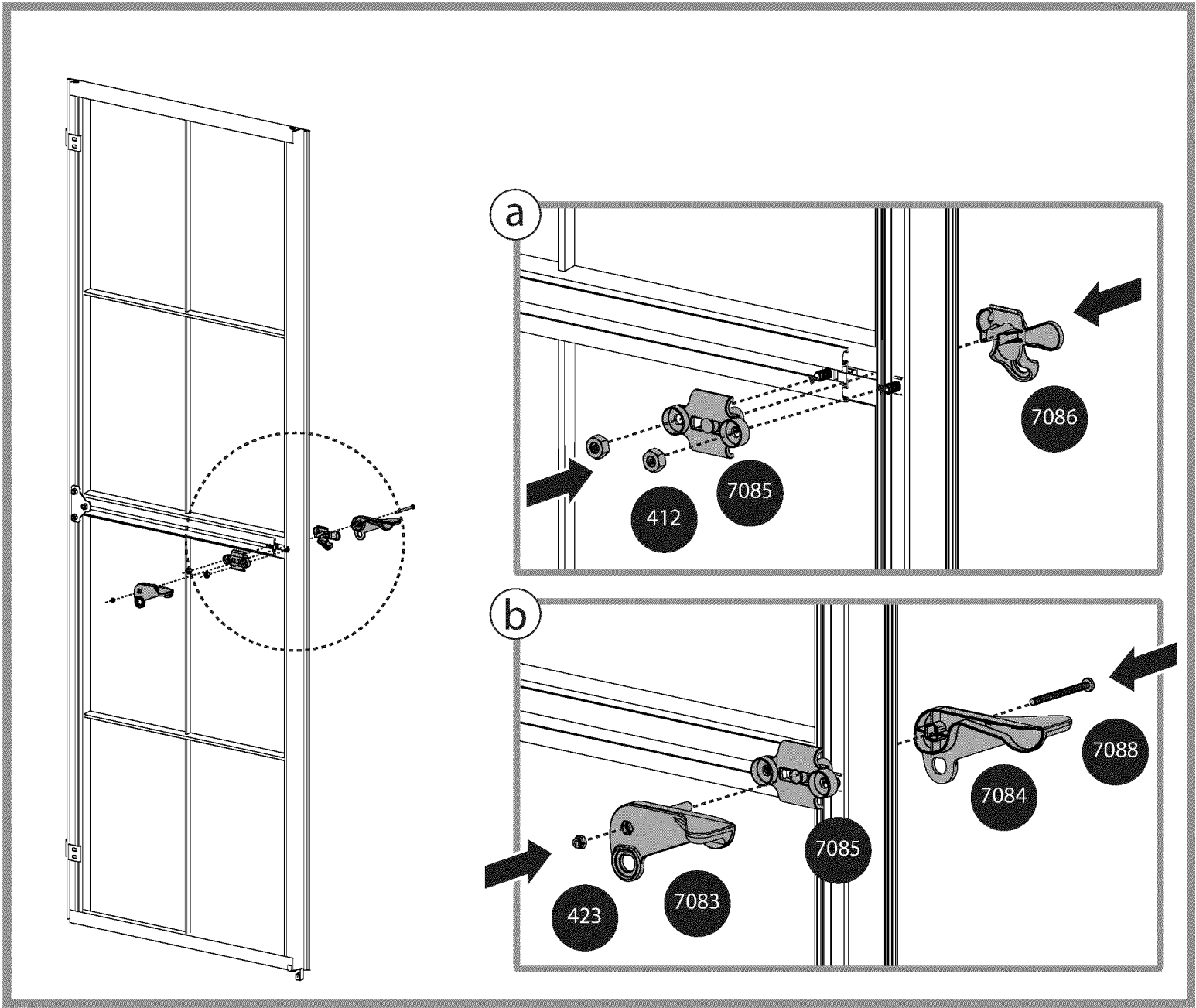

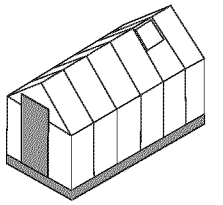

463x2

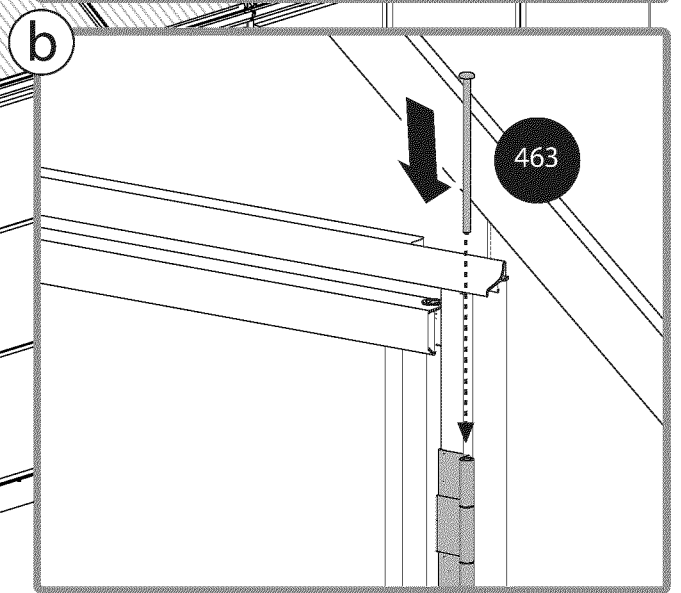
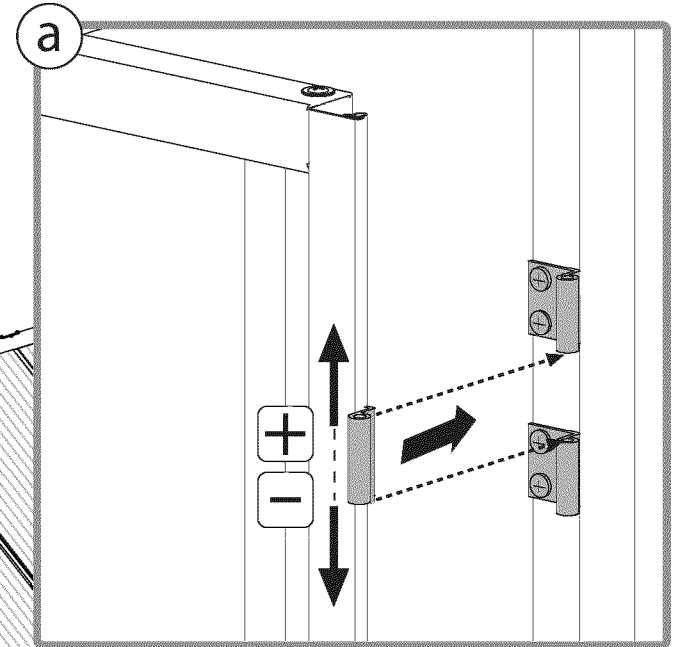
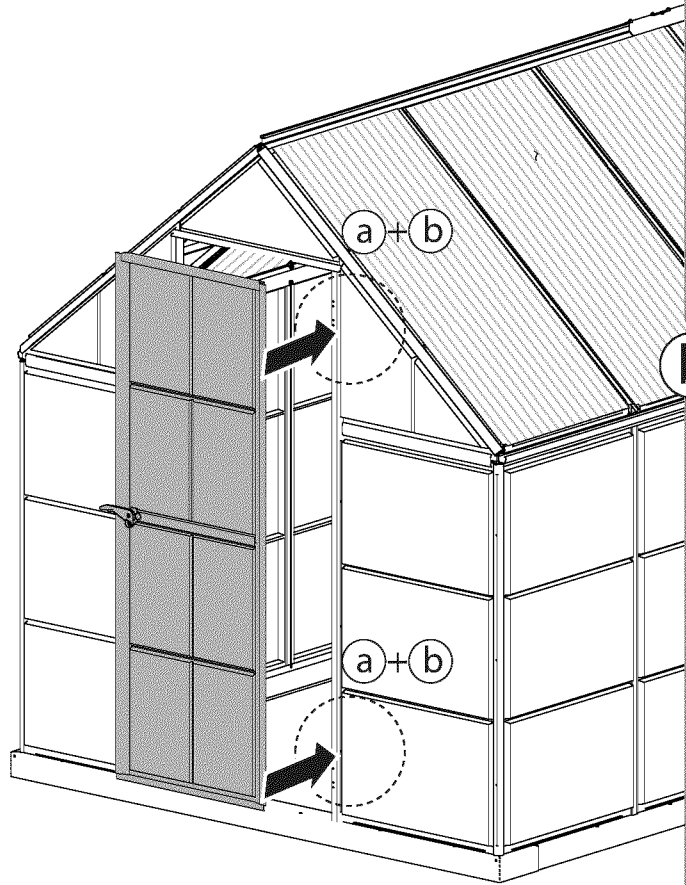
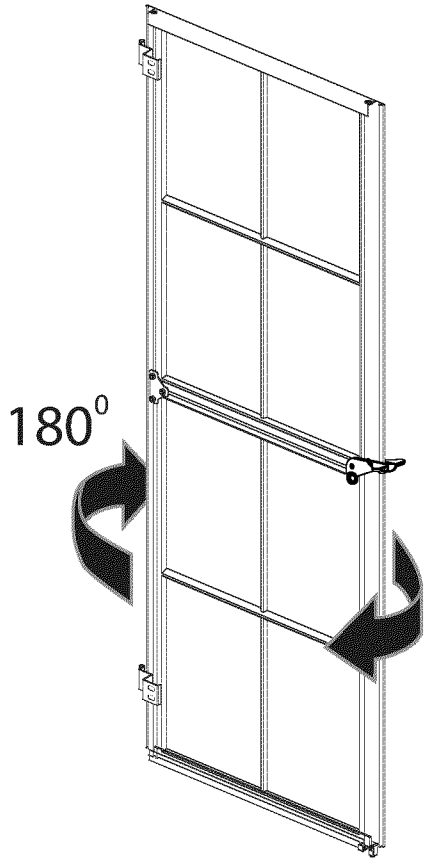

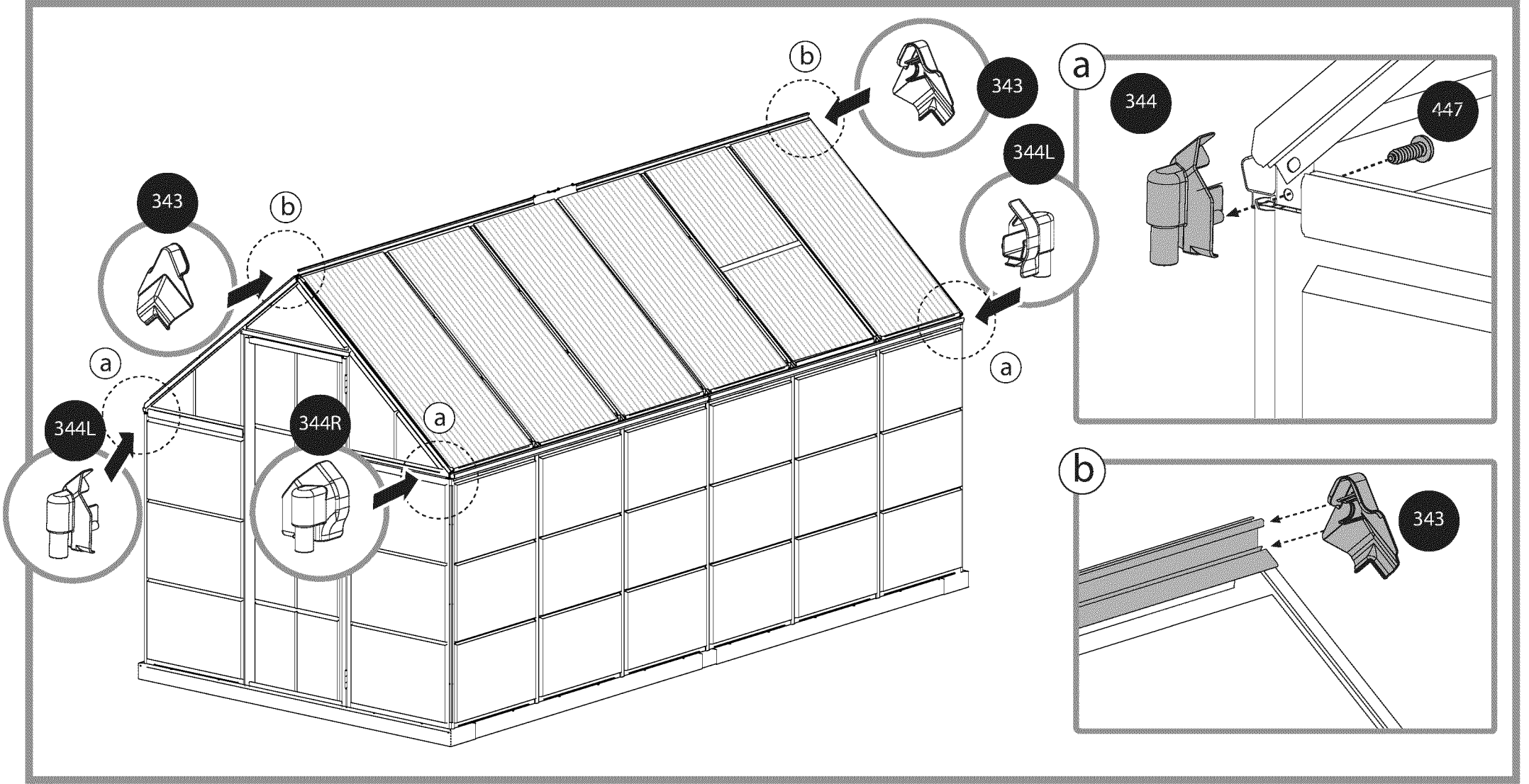
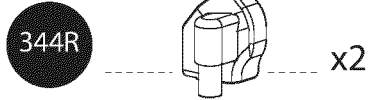
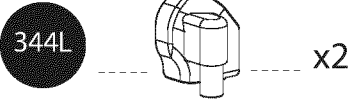
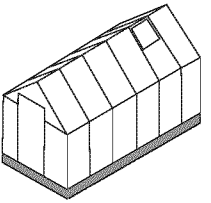

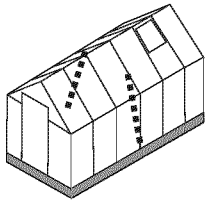

926

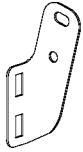

x2

461



x4

411



x4

412



x8

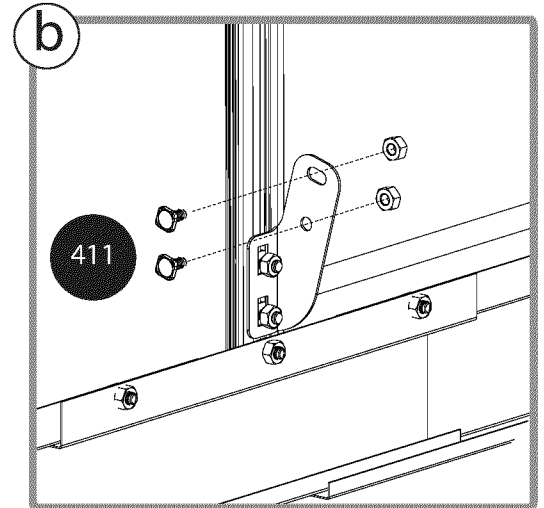
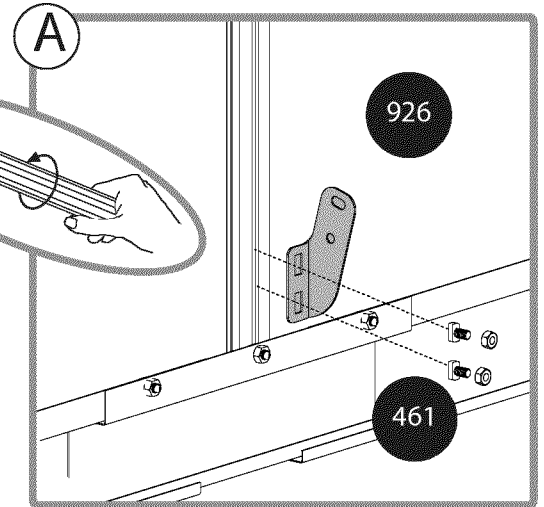
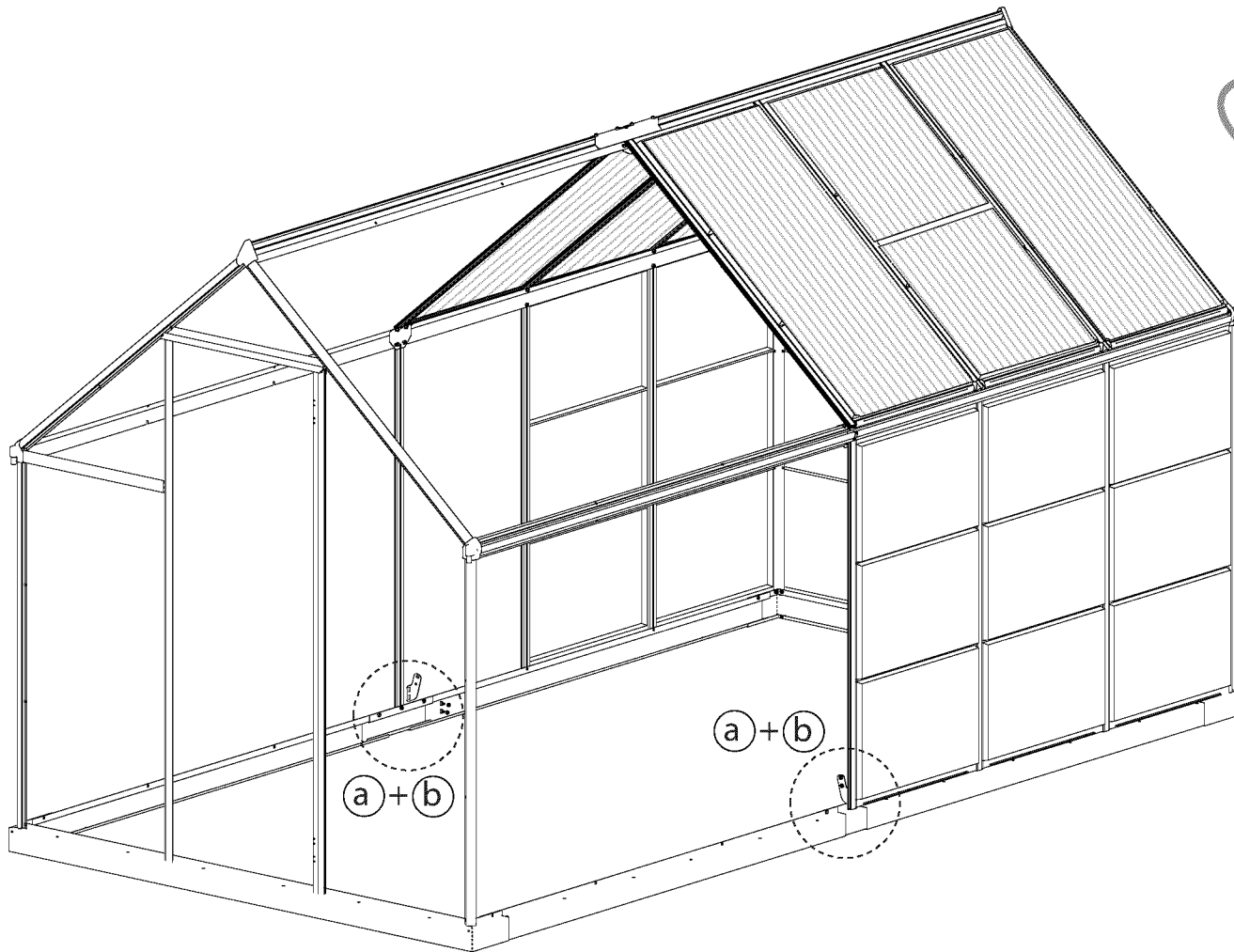

65

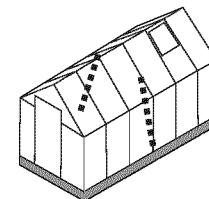

966

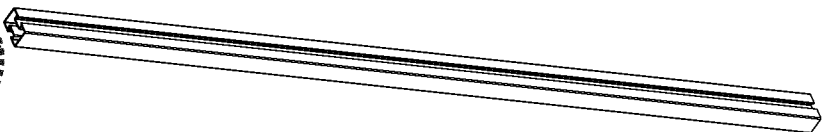
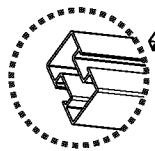

x2

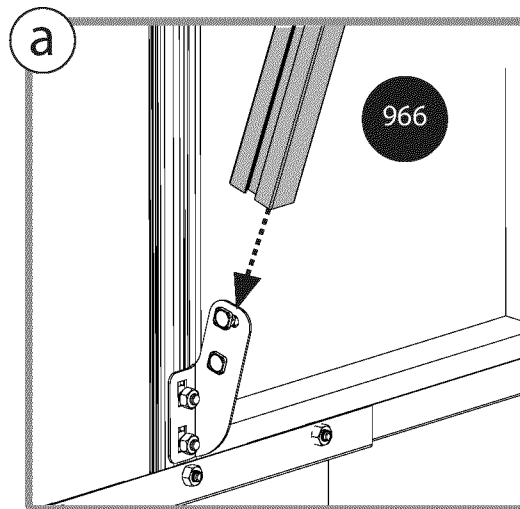
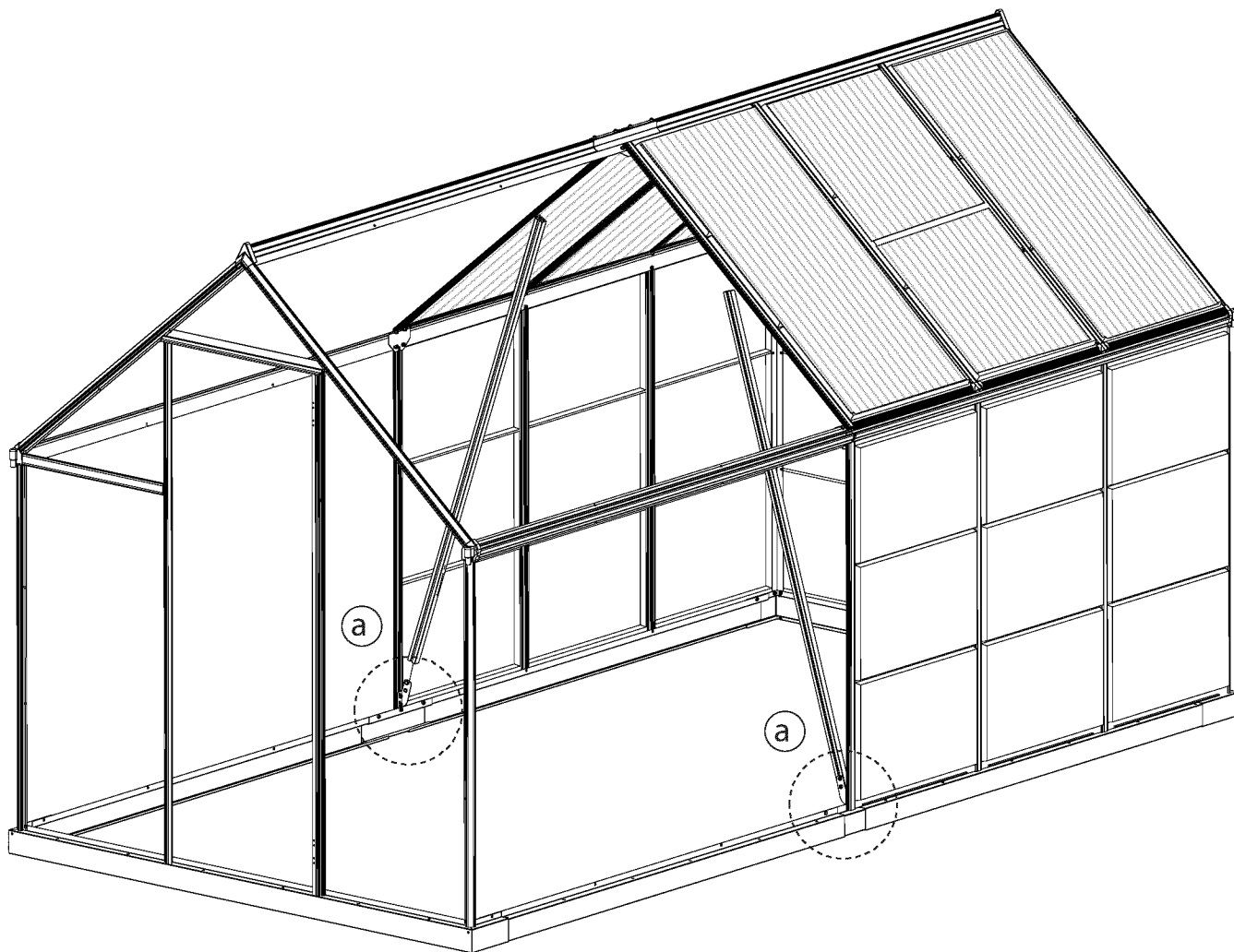

66

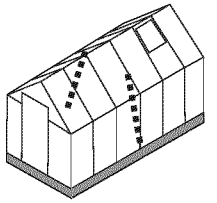

456

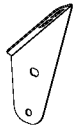

x2

461

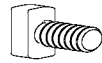

x4

411



x8

412



x8

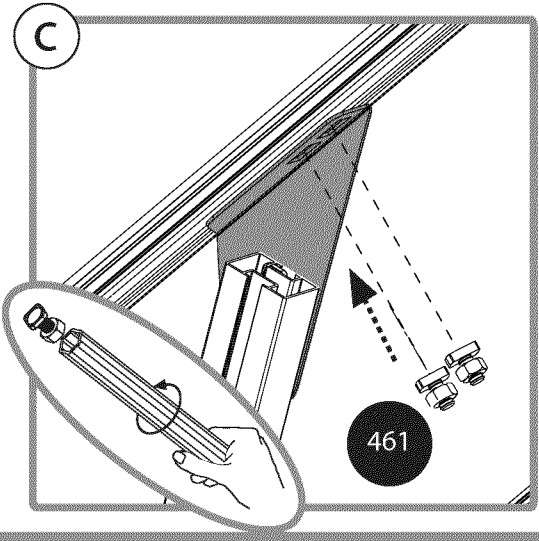
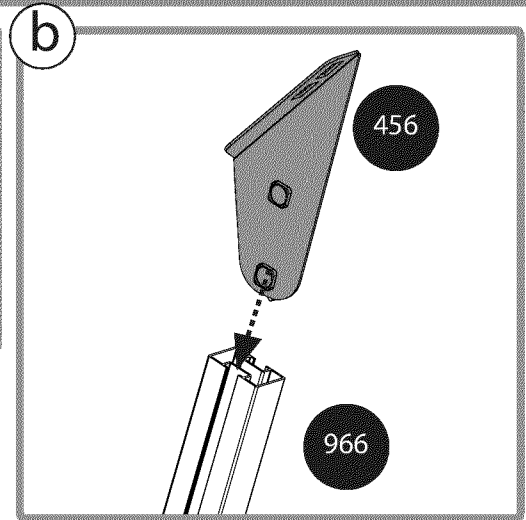
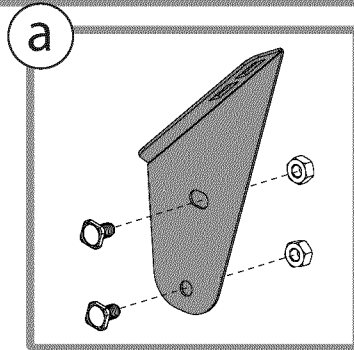
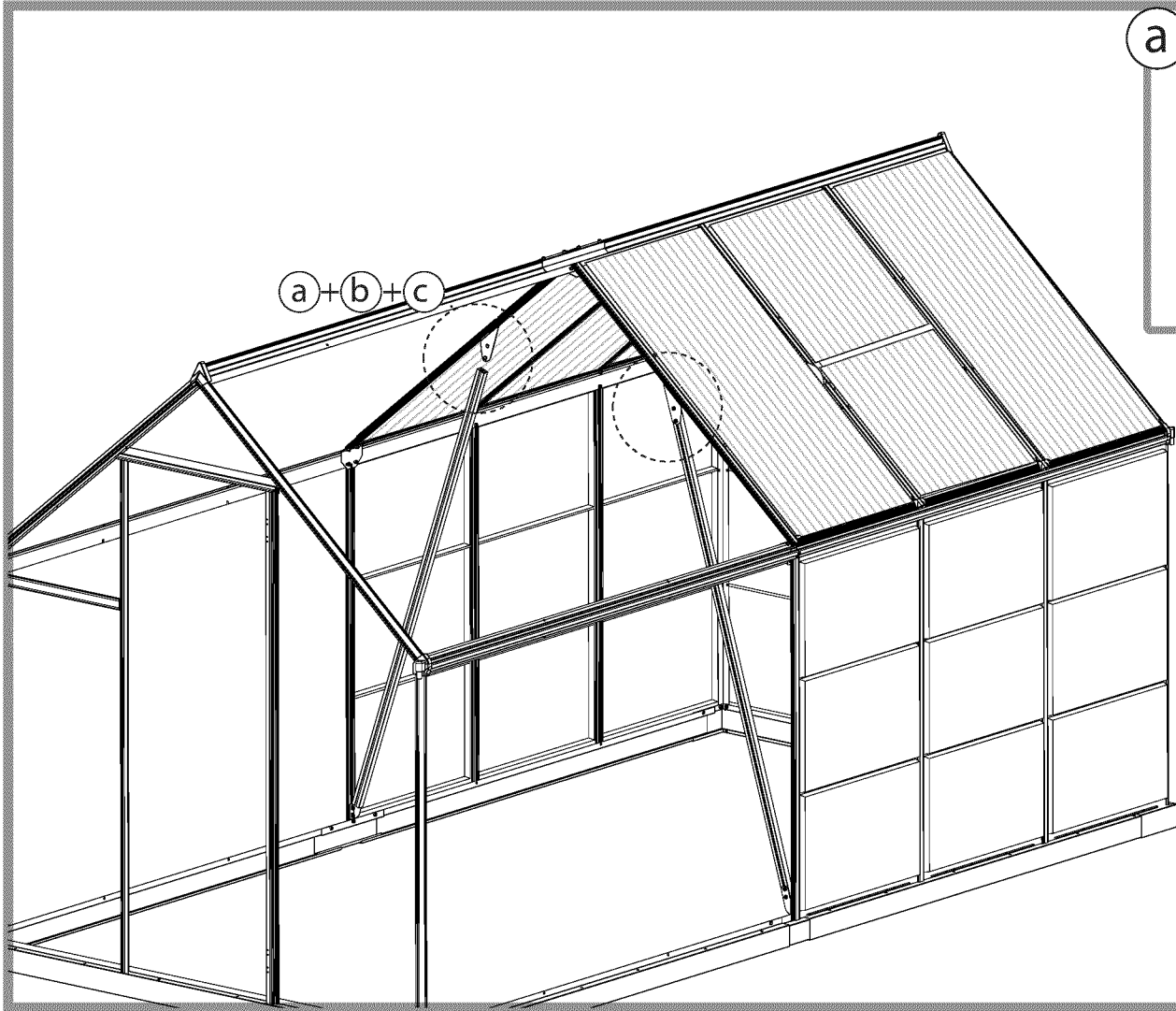

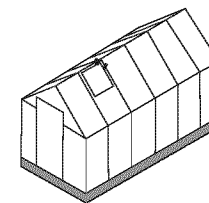

459

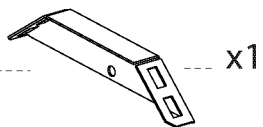

461

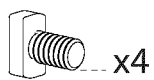

412

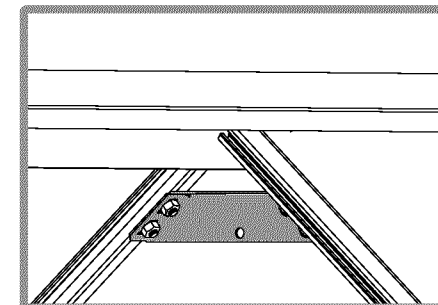
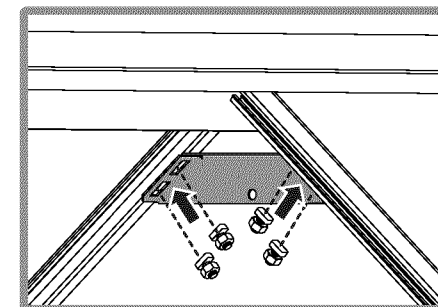
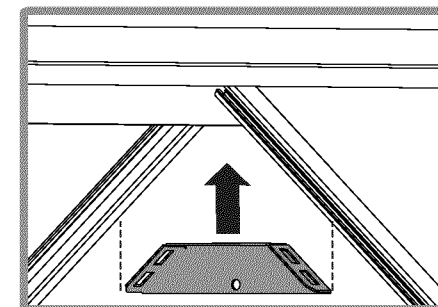
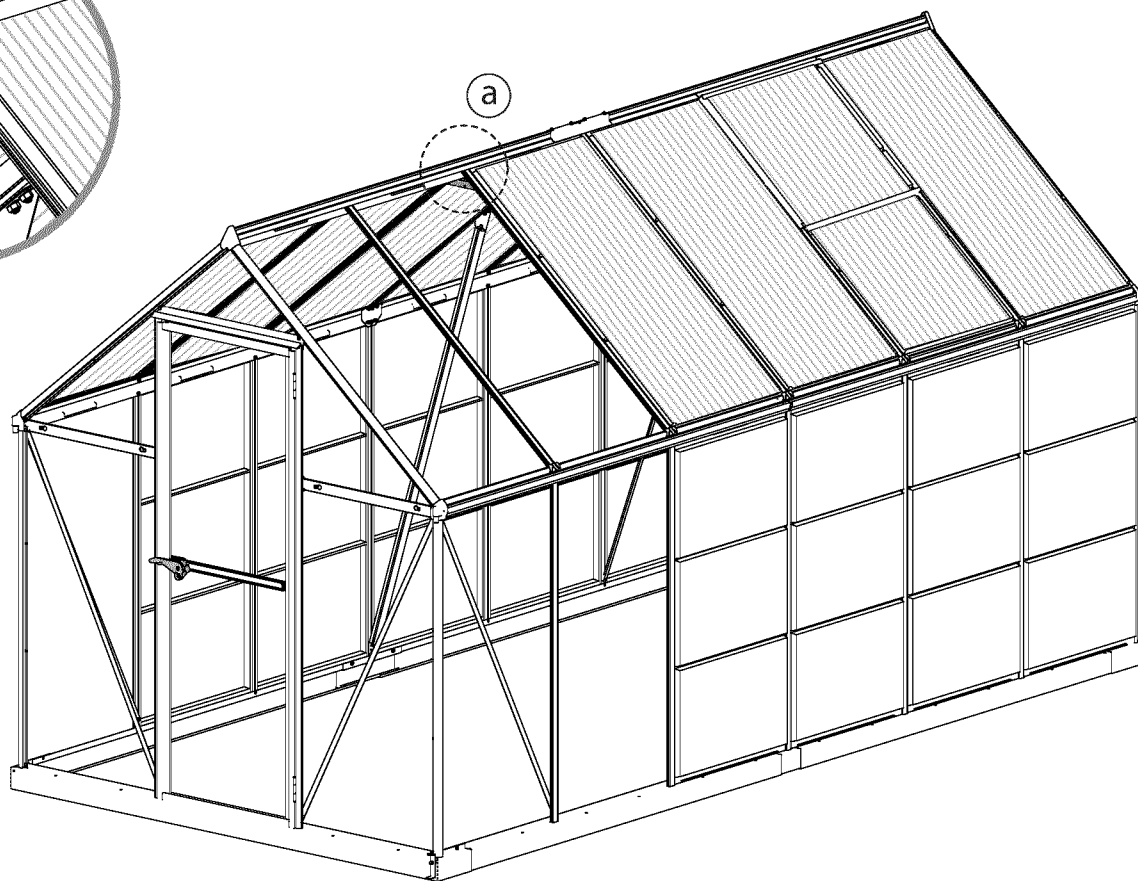
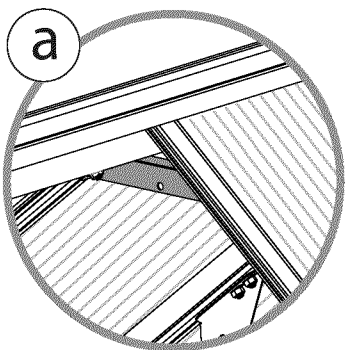

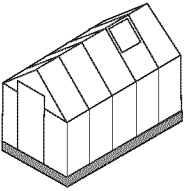

M96  x6

P328  x34

